



Ultra UV₂[™]
ULTIMATE UV WATER SANITIZER

INSTALLATION & OPERATIONS MANUAL

IMPORTANT SAFETY INSTRUCTIONS READ AND FOLLOW ALL INSTRUCTIONS

WARNING

When using this electrical equipment, basic safety precautions should always be followed, including the following:

- Follow all applicable electrical codes.

- Turn off power at main source before making any electrical connections or servicing the unit.
- To reduce the risk of electric shock, injury or death disconnect unit from power supply
- Follow the instructions or risk of serious injury or death could occur!
- To reduce risk of injury, do not permit children to use this product unless they are closely supervised at all times.
- Risk of electric shock. Install at least 5 feet (1.5m) from inside wall of pool, hot tub or spa using nonmetallic plumbing.
- This product shall only be connected to a power supply receptacle protected by a ground fault circuit interrupter.

UV EXPOSURE & PROTECTION:

UV-A and UV-B radiation can have adverse short and long term effects on the eyes and skin. Never look directly at a UV lamp that is connected to a power source. Avoid UV skin exposure at all times.

DANGER

RISK OF INJURY

- A) Replace damaged cord immediately.
- B) Do not bury cord
- C) Connect to a grounded, grounding type receptacle only.

SAVE THESE INSTRUCTIONS

 **UL LISTED**
Pool, Spa & Pond
Water Sanitizer 4BJ1

 EPA Registered
#084221-AZ-001

8175 W. Buckeye Rd., Phoenix, AZ 85043
Toll Free: 1.800.621.5886 • Fax: 480.753.3397
Paramount@1Paramount.com • www.1Paramount.com

Paramount

US and Foreign patents and patents pending see www.1paramount.com/support/patent-numbers/
Paramount products are designed by Paramount in Phoenix, Arizona, United States of America
004-027-9000-00 REV05 Publish 082422 ECN_2282 ©2022 Hayward Industries, Inc.

Signal Words and Symbols Used In This Manual

This Owner's Manual and Installation Guide contains specific precautions and symbols to identify safety-related information. You will find DANGER, CAUTION, WARNING and NOTICE symbols which require special attention. Please read them carefully and follow these precautions as indicated! They will explain how to avoid hazards that may endanger you or persons using or maintaining your pool or spa.



Indicates a hazardous situation which, if not avoided, will result in death or serious injury.



Indicates a hazardous situation which, if not avoided, could result in death or serious injury.



Indicates a hazardous situation which, if not avoided, could result in minor or moderate injury.



Is used to address practices not related to physical injury.

PLEASE REVIEW THE OWNER'S MANUAL AND INSTALLATION GUIDE IN ITS ENTIRETY AND HEED ALL SAFETY INFORMATION. Failure to follow these instructions and warnings can result in DEATH OR SERIOUS INJURY.

SAVE THESE IMPORTANT SAFETY INSTRUCTIONS

For the most current version of this install manual go to:
www.1paramount.com/support/download-manuals

Table of Contents

WELCOME	2
ULTRA UV2 SYSTEM SIZING	3
POOL, SPA, FOUNTAIN, WATER FEATURE AND WATER FALL SIZING CHART.....	3
LOCATING THE ULTRA UV2 UNIT	4
INSTALLING INLET/OUTLET UNIONS	4
PLUMBING THE ULTRA UV2 UNIT	4
TYPICAL PLUMBING WITHOUT AND WITH BYPASS.....	5
PLUMBING THE ULTRA UV2 UNIT WITH OPTIONAL BYPASS VALVE	5
INSTALLING OPTIONAL FLOW SWITCH IF THE TOP OF THE UNIT IS BELOW WATER LEVEL.....	5
PARALLEL PLUMBING WITHOUT AND WITH BYPASS	6
MULTIPLE PORT PLUMBING FOR 3 LAMP UNITS WITHOUT AND WITH BYPASS	6
PROVIDING ELECTRICAL POWER TO THE ULTRA UV2 UNIT.....	6
ELECTRICAL BONDING	7
WIRING INSTRUCTIONS ON THE ULTRA UV2	7
SYSTEM START-UP	8
NORMAL OPERATION	9
WINTERIZE / SERVICE OPERATION	9
WINTERIZATION OF YOUR ULTRA UV2 UNIT	9
CONSUMER OPERATING INSTRUCTIONS QUARTZ TUBE MAINTENANCE.....	10
SCHEDULED UV LAMP(S) REPLACEMENT.....	12
TROUBLESHOOTING.....	13
HEAD LOSS CURVES.....	15
ULTRA UV2 PART NUMBERS.....	16

WELCOME

The Ultra UV2 unit is designed for use in swimming pools, spas, fountains, water features, waterfalls, fish ponds and the like.



It is not designed for use in potable (drinking) water installations. Use of this product in applications other than those indicated above will void your warranty and could be harmful to your health or the health of others.

GENERAL PRODUCT INFORMATION

Water circulates through the Ultra UV2 chamber and around the quartz tube where the UV-C lamp(s) (1 to 3 lamps depending on the model) are housed. The UV-C lamp emits a light wave spectrum (253.7 nm wavelength) to immediately inactivate 99.9% of micro-organisms such as Crypto, Giardia, other single celled waterborne microorganisms and algae which are resistant to chlorine. This provides a cleaner, clearer swimming environment with zero harmful by-products and dramatically reduces the amount of chlorine needed to maintain an adequate level of residual sanitizer. The Ultra UV2 unit has been sized to produce these important UV rays in the same intensity as is required for Class A potable drinking water, which is 30,000 micro watts/cm² (30 mJ). Confirm the size unit your application needs by using the sizing charts on page 3, to obtain the proper maximum system killing power.

Please note the minimum and maximum flow rates for each Ultra UV2 lamp configurations.



CAUTION

DO NOT USE THIS UNIT FOR POTABLE (DRINKING) WATER SANITATION.

ULTRA UV2 SYSTEM SIZING

In order to ensure that your Ultra UV2 unit functions with the proper water exposure time to achieve the desired water sanitation, it is important to provide the proper water flow rate through the Ultra UV2 unit. If water passes through the unit too quickly, the microorganism's exposure time to the UV lamp(s) produced rays will not be sufficient to obtain the desired rate of sanitation. **Please note that the minimum posted flow rate must be met or exceeded to ensure proper system performance.** The water flow rate through the UV unit is governed by the piping of your water vessel and the size and output of your circulation pump. Consideration to the application for the UV unit must be determined. Fish ponds, as an example, have different requirements than swimming pools, spas, water features, fountains, or waterfalls, as noted elsewhere in this manual.

NOTICE

FIRST STEP IN STARTING YOUR INSTALLATION

Inspect the Ultra UV2 unit for damage, paying close attention to the quartz tube.

POOL, SPA, FOUNTAIN, WATER FEATURE AND WATER FALL SIZING CHART

Fig. 2 Swimming pools and similar water vessels are simple to calculate. See chart below.

Ultra UV2 Part Number	Minimum Flow Rate (GPM) / (m ³ /hr)	Maximum Flow Rate (GPM) / (m ³ /hr)	Max Pool Volume 12 Hr. Turnover (Gallons) / (m ³ /hr)	Max Pool Volume 8 Hr. Turnover (Gallons) / (m ³ /hr)	Minimum Operating Pressure (psi) / (bar)	Maximum Operating Pressure (psi) / (bar)
004-422-2025-00 230V w/ 1 UV-C Lamp	10 / 2.27	46 / 10.4	33120 / 125.4	22080 / 83.6	5 / .345	50 / 3.45
004-422-2021-00 120V w/ 1 UV-C Lamp						
004-422-2026-00 230V w/ 2 UV-C Lamps	20 / 4.54	80 / 18.2	57600 / 218.0	38400 / 145.4	5 / .345	50 / 3.45
004-422-2022-00 120V w/ 2 UV-C Lamps						
004-422-2027-00 230V w/ 3 UV-C Lamps	*30 / 6.81	*130 / *29.5	93600 / 354.3	62400 / 236.2	5 / .345	50 / 3.45
004-422-2023-00 120V w/ 3 UV-C Lamps						

All capacities are nominal Note: Multiple Ultra UV2 units installed in parallel can be used for flow rates beyond those specified herein. (See page 6)

* Header size should be 2 1/2" or 3" and split to two 2" pipe headers at the inlet and outlet connections. (See page 6)

LOCATING THE ULTRA UV2 UNIT

Your unit can be installed indoors or outdoors. When considering the location for your Ultra UV2 unit, keep it close to your power source. Check the silver product label for the voltage of the unit. The Ultra UV2 unit will need to be powered from either a 120V/15A/50/60Hz or 230 V/15A/50/60Hz electrical circuit (which **MUST** match the unit power requirement noted on the silver product label on the Ultra UV2 unit). **DO NOT CONNECT TO ELECTRICAL POWER NOT SPECIFIED FOR YOUR UNIT.** Plug in units must be installed on a GFCI outlet. The GFCI must be outdoor rated if installed outdoors. 230V Ultra UV2 units can be wired for 120V or 230V.

Fig. 3

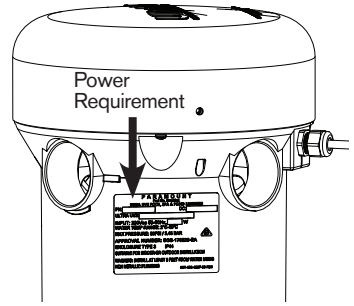

WARNING

DO NOT CUT OFF the plug from the 120V Ultra UV2 units and hardwire it. This does not meet the U.L. installation method and voids the U.L. listing.

MOUNTING THE UV UNIT ON A SOLID BASE

Before you make the permanent plumbing connections be sure the ULTRA UV2 unit is on a solid level base making sure your plumbing connections align. Make sure there is ample space above the unit for lamp replacement. After making your plumbing connections, anchor the unit to the base using the four 1/4" mounting holes. **FAILURE TO PROPERLY SECURE THE UNIT MAY CAUSE NOISE OR VIBRATION.**

INSTALLING INLET/OUTLET UNIONS

The Ultra UV2 unit comes with female socket glue-in inlets and outlet openings. **ABS to PVC multipurpose glue** and appropriate primer must be used to glue fittings into the ULTRA UV2 body. The 4 outlets (top) and 4 inlets (bottom) provide the most versatile piping alternatives for the installer. The ULTRA UV2 unit comes with (2) unions (See page 16 for part numbers). Multiple inlets and outlets can be used to manage higher flow rates of **3 lamp units which come with 4 unions and 4 plugs.**

NOTE: The use of multiple inlets/outlets will require additional unions. Use the plugs provided with the Ultra UV2 in the unused inlets and outlets. To install the unions onto the Ultra UV2 unit, glue and insert the unions spigot end into the inlet and outlet opening selected. Then, using the six plugs provided, glue the plugs into the remaining unused plumbing openings. Hand tightening the union nuts until snug is sufficient. **DO NOT OVERTIGHTEN.** Over tightening may break the molded plastic parts of the unions. Once you are confident that you have installed the inlet and outlet union halves successfully, you will be ready to glue your plumbing into the union sockets once the Ultra UV2 unit is positioned on the mounting surface.

NOTICE

A 24 hour cure time is required before pressure can be applied to the Ultra UV2 unit.

PLUMBING THE ULTRA UV2 UNIT

All plumbing methods are illustrated with and without the bypass option. Your Ultra UV2 unit will need to be plumbed into the circulation system. **The Ultra UV2 unit must be installed directly after the filter. Installing a bypass is not recommended.** The only reasons for installing an Ultra UV2 bypass: 1. To allow for removal of the UV unit, while still allowing the system to operate with water flowing through the bypass. 2. If system pressure testing above 50 psi is required (max Ultra UV2 pressure is 50 psi/ 3.45 bar). The acceptable reasons for removal include winterization, servicing, off site repairs and replacement. **If a bypass is required it must be installed & operated per instructions on pages 5 - 6.** Before bypassing the Ultra UV2 for removal, turn off all pumps and allow the pool system's pressure to drop to zero.

AN IMPROPERLY USED BYPASS INSTALLATION MAY NOT MEET THE MINIMUM REQUIRED FLOW RATE AND COULD POTENTIALLY DAMAGE THE ULTRA UV2 UNIT.

NOTICE

Do not plum the Ultra UV2 with a bypass unless absolutely needed. Failure to follow the instructions can result in damage to the Ultra UV2 that is not covered by the warranty.



DANGER

Turn off the power at the main source before disconnecting or connecting the Ultra UV2.

NOTICE

Strongly recommend using supplied unions.

GLUING PIPING TO THE UV UNIT

Two Inlet/Outlet unions are supplied on our 1 & 2 lamp units and 4 unions are supplied on 3 lamp units.. Your PVC supply piping should be glued into the union tail pieces using an appropriate primer and **ABS to PVC cement**. Inlet piping should be glued and should not rest solely upon the unions, to avoid stressing or breaking the unions. Allow the glue to set following the glue manufacturers recommendations before pressure testing. A minimum of 24 hours is recommended. Maximum test pressure for the Ultra UV2 is 50 PSI / 3.45 BAR as noted on the silver label on the unit. If local codes require the pressure test to be higher than the max operating pressure on the silver label use the bypass (if the unit is plumbed with a bypass) to allow the Ultra UV2 to be only left at or below the max operating pressure.

A

PLUMBING THE ULTRA UV2 UNIT WITH OPTIONAL BYPASS VALVE

The only reasons for installing an Ultra UV2 with bypass valve:

1. To allow for removal of the UV unit for **winterization, servicing, repairs, or replacement**, while still allowing water to flow through the system.
2. If system pressure testing above 50 psi is required (max Ultra UV2 pressure is 50 psi/ 3.45 bar).

B

INSTALLING OPTIONAL FLOW SWITCH IF THE TOP OF THE UNIT IS BELOW WATER LEVEL

The pressure switch will always be on if the Ultra UV2 unit is plumbed below water level. To prevent damage to the unit and its surroundings an optional flow switch must be installed. If the Ultra UV2 unit is plumbed on a bypass, the optional 2 inch Flow Switch (part #004-402-0010-00 for 220v or part #004-421-3824-00 for 120v), must be on the outlet side of the Ultra UV2 unit and plumbed after the two way valve and before the tee into the return line. Please refer to the instructions supplied with the flow switch for plumbing and wiring.

TYPICAL PLUMBING WITHOUT AND WITH BYPASS

The inlet(s) is at the bottom of the unit and the outlet(s) at the top. The maximum operating pressure for the Ultra UV2 is 50 PSI / 3.45 BAR. The minimum operating pressure is 5 PSI / .345 BAR. Please refer to the silver label on the unit for max. operating pressure.

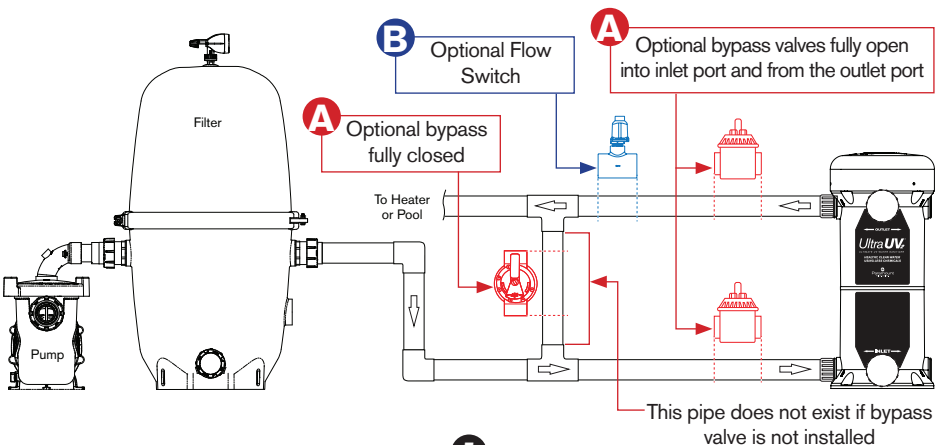

PARALLEL PLUMBING WITHOUT AND WITH BYPASS

Plumbing Ultra UV2 units in parallel for large bodies of water with high flow rates.

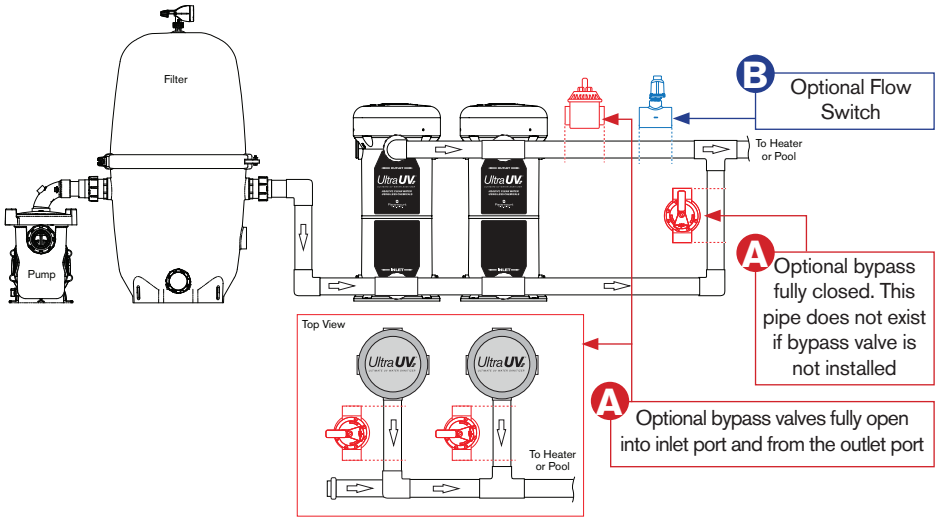

MULTIPLE PORT PLUMBING FOR 3 LAMP UNITS WITHOUT AND WITH BYPASS

Ultra UV2 3 lamp units require 2 inlets and 2 outlets be plumbed, see page 5.

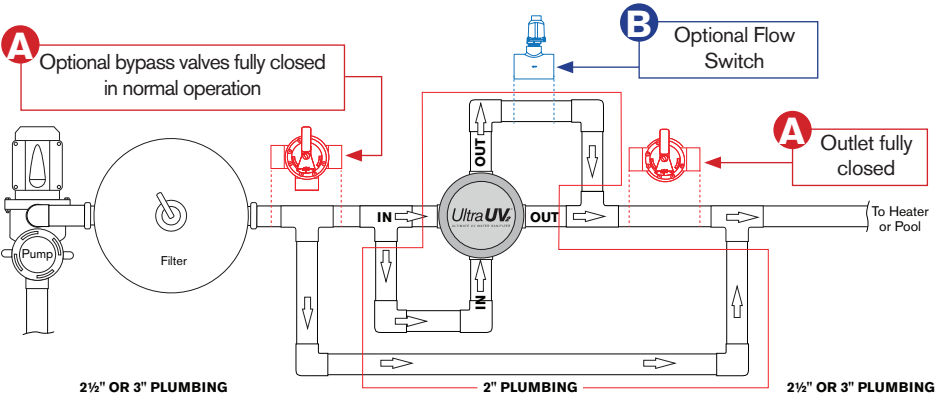

PROVIDING ELECTRICAL POWER TO THE ULTRA UV2 UNIT

⚠️ GROUNDING

This product must be grounded. If it should malfunction or break down, grounding provides a path of least resistance for electrical current to reduce the risk of electric shock. This product is equipped with a cord having an equipment-grounding conductor and a grounding plug. The plug must be plugged into an appropriate outlet that is properly installed and grounded in accordance with all local codes and ordinances.

⚠️ DANGER

Improper connection of the equipment-grounding conductor can result in a risk of electrocution. Check with a qualified electrician or service personnel if you are in doubt as to whether the outlet is properly grounded. Do not modify the plug provided with the product - if it will not fit the outlet; have a proper outlet installed by a qualified electrician. Do not use any type of adapter with the product.

GROUND FAULT CIRCUIT INTERRUPTER PROTECTION

To comply with the national electrical code (NFPA 70) and to provide additional protection from the risk of electric shock, this unit should only be connected to a receptacle that is protected by a ground circuit interrupter (GFCI)

The electrical power rating for your Ultra UV2 unit is shown on the silver label located on the outside of the unit. (Fig. 3 on page 4) Make sure the supplied power meets the units requirements. Connecting any power than that listed on the rating label will damage the unit and will **VOID your limited warranty**.

120V 50/60Hz Ultra UV2 units

If your supply power is 120V 50/60Hz the label on your unit should match. Low power consumption makes operating this unit very economical. Your Ultra UV2 120V unit is supplied with a weatherproof power cord terminating with a 3-prong grounded NEMA plug. An outdoor rated ground fault circuit interrupter must be installed in the electrical outlet serving the Ultra UV2 unit (subject to your local electrical codes).

⚠ WARNING

Do not cut the plug off the electrical cord and connect it directly to a 120V power source. If this is done your warranty is voided and the U.L. listing is invalidated.

Note: Some jurisdictions do not allow corded connections for these types of appliances. Check your local and national electrical codes. If hard wiring is required it must be done by a licensed electrical service person. The Ultra UV2 unit uses voltage sensitive ballast 120/230 volts. When wiring the unit 230 volts the black and white wires are wired hot and the green wire is ground. Should the electrical cord become frayed or damaged in the future, unplug it from the power receptacle and replace it immediately.

230V 50/60Hz Ultra UV2 Units

If your supplied power is 230V 50/60Hz the label on your unit should match. Remember you CANNOT operate your Ultra UV2 on any power supply other than that indicated on the units silver label.

NOTICE

Have this work done by a licensed electrical technician.

ELECTRICAL BONDING

Locate the bonding lug next to the power cable (Fig. 4). To reduce the risk of electric shock, this terminal must be connected to the bonding lug means provided in the electrical supply service panel with a continuous copper wire equivalent in size to the circuit conductors supplying this equipment. To reduce the risk of electric shock, connect the local common bond grid in the area of the pool or spa to this terminal with an insulated or bare copper conductor per national and local codes. **The electrical installation is now complete.**



WIRING INSTRUCTIONS ON THE ULTRA UV2

1. Install the conduit into the seal-tight connector. Replace the conduit if it is too short.
2. Lift the grommet from the mounting plate and feed the two power wires & and ground wire. Use the supplied tube of silicone and cover the wires at the junction of the conduit connector. Reinstall the grommet to the mounting plate.
3. Attach one power leg (most likely black) to the upper right position of the terminal block. Attach one power leg (most likely white) to the lower right position of the terminal block.
 - **NOTE: The terminal block is sized to accept a spade terminal for 18-22AWG wire.**
4. Cut the ground wire to length and attach an 18-22 AWG ring terminal. Remove the nut from the left ground post. Place the ring terminal over the ground post. Reattach the nut.

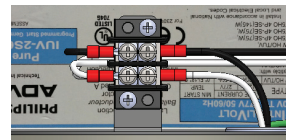
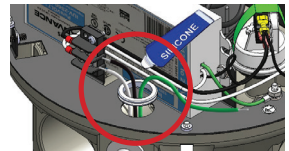
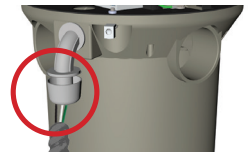

⚠ WARNING

Failure to silicone the wires in the connector could result in water from a leak in the unit leaking down the conduit and causing non-warranted damage to other components.

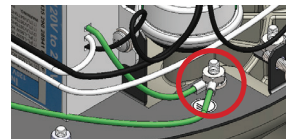

SYSTEM START-UP

NOTICE

Do not connect the pressure switch until the pool is operational!

PRESSURE SWITCH

The Ultra UV2 unit is equipped with pressure switch that does not allow the UV lamp(s) inside the unit to light unless there is at least **2 PSI (0.137 BAR)** inside the Ultra UV2 reactor chamber. This will ensure that the lamp(s) will illuminate when the Ultra UV2 unit has water flowing through the reactor. The lamps will only illuminate when the pressure switch senses a minimum starting pressure of 2 psi (0.137 bar).

CONNECTING PRESSURE SWITCH

Disconnect power to the Ultra UV2 unit. Remove the cover (Fig. 5) and locate the pressure switch and the loose lead with the female spade connector (Fig. 6). Connect the female spade connector to the male top spade connector on the pressure switch (Fig. 7). Replace the cover and restore power to the unit. Turn on the pump and the flow should activate the switch. The unit should be on and the lamps illuminated. Look at the "Glow Ring" in the center of the unit to check that all lamps are lit. If the lamps are not on, first verify the unit is operating at 5 psi or more, then refer to the troubleshooting section of this manual on page 13.

NOTICE

The filter gauge DOES NOT indicate the pressure in the UV unit



WARNING

Do not look directly at the lamps. Serious injury will occur.

Fig. 5

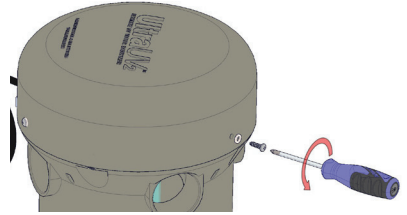

Fig. 6

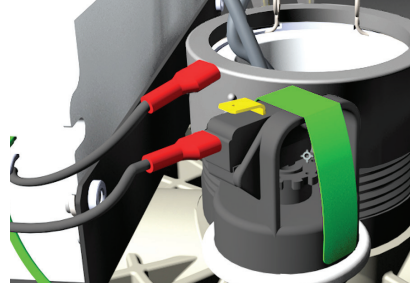
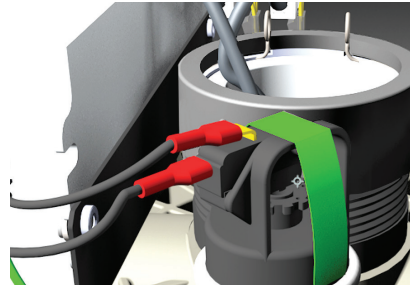

Fig. 7



If the Ultra UV2 does not illuminate check the following:

1. Adjust the system valves so there is flow through the Ultra UV2 unit and not diverted to other devices.
2. The pump is producing enough pressure. If you have a variable speed pump verify you are set at a high enough speed to produce enough pressure to turn on the lamps.

WATER CHEMICAL BALANCE

If you have installed your Ultra UV2 unit on any water vessel other than fish ponds or ponds with live plants, it is important that you check and adjust the chemical balance of the water. The Ultra UV2 unit dramatically reduces the need for chemical sanitizers, but a minimum sanitizer residual must be maintained.

NORMAL OPERATION

Configuration for Ultra UV2 units installed with bypass.

During normal operation the inlet valve #2 and outlet valve #3 should be completely open and the bypass valve #1 should be completely closed. Any

partial opening of the bypass valve can drop the flow rate below the required minimum and cause damage to the Ultra UV2 unit. This instruction applies to all systems with a single speed or with a variable speed pump. This type of damage is not covered under the factory warranty.

Fig. 20 Outlet Valve #3 Open

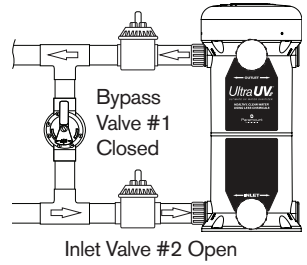
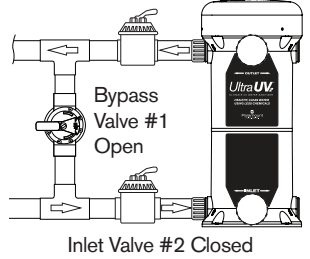

Fig. 21 Outlet Valve #3 Closed



WINTERIZE / SERVICE OPERATION

Configuration for Ultra UV2 units installed with bypass.

Bypass operation is used for winterization or servicing/replacing the Ultra UV2 unit. The bypass valve #1 should be full open and the inlet valve #2 and the outlet valve #3 should be completely closed.

WINTERIZATION OF YOUR ULTRA UV2 UNIT

If you are in a sub freezing climate you must winterize the Ultra UV2 using either option #1 or #2. Failure to do so will cause damage to the unit, which is **not covered under the warranty**.

Option #1 - Removing the unit for the winter: Turn off the power to the unit. Disconnect the unions on the plumbing to ensure that the unit is completely drained. Now, with the power off, disconnect the unit from its power source and place the drained unit in a safe place that has a sustained temperature above freezing. Reinstall after the temperatures are considerably above freezing.

Option #2 - Leaving the unit in place for the winter: Turn off the power to the unit. Disconnect the unions on the plumbing to ensure that the unit is completely drained. There is a cup in the bottom of your unit that the quartz tube nests in. This cup does not drain completely (Fig. 30). **To remove the water from this cup you must first remove the lamp array and quartz tube** Fig. 22 (See page 4). Turn the unit on its side with the unions facing down until all of the water has drained. Reconnect the unit, the quartz tube, lamps, and cover. You may store the lamps and quartz tube in a safe place.

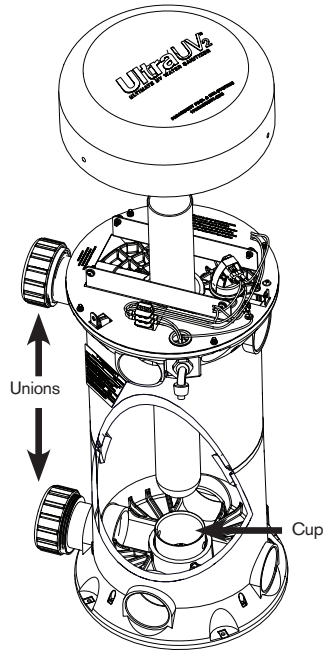

Fig. 22

CONSUMER OPERATING INSTRUCTIONS QUARTZ TUBE MAINTENANCE

NOTICE

to ensure optimum performance.

Cleaning the quartz tube:
The quartz tube requires
cleaning every 6 months

1. Turn off all power to the ULTRA UV2 unit and all other pool equipment. Unplug the unit from its power receptacle or turn OFF the circuit breaker that is the ULTRA UV2's power source. Before proceeding to step 2 allow at least 15 minutes for the lamp(s) in the unit to cool.

DANGER

Never remove the electrical enclosure cover without first disconnecting the power (power source) for the Ultra UV2 unit. Never remove the Ultra UV2 unit's cover without turning off the pump.

2. Remove the three screws that secure the plastic cover then remove Fig. 1.

WARNING

Before removing lamps you must wear protective rubber gloves and safety eye wear. Do not handle a hot lamp or serious burns will occur.

NOTICE

& greatly shorten lamp life.

Do not touch the glass part of the lamp as body oils will create hot spots

3. Disconnect all lamps by pressing the release tabs on connectors and gently pulling apart. Fig. 8
4. Remove the spring clip Fig. 9. Carefully lift the old lamp assembly, including lamp holder, from the quartz tube Fig. 10. Do not pull excessively on the lamp wires. Set aside the lamp assembly in a safe area to avoid breaking or chipping.
5. Turning counter-clockwise, unscrew and remove the round aluminum sealing nut. Fig. 11
6. Carefully lift the aluminum compression washer from the top of the quartz tube making sure not to lose the black gasket that cushions the edge of the quartz tube. Fig. 12
7. Grip quartz tube with both thumbs inside and pull up. Once the O-ring breaks free, the quartz tube should lift out easily. Fig. 13

NOTICE

The quartz tube is fragile, be sure to handle it with proper care and do not set it down on a hard surface. Do not use abrasive cleaners or pads.

Fig. 8

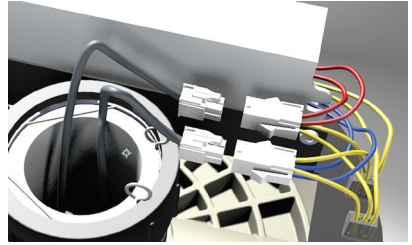

Fig. 9

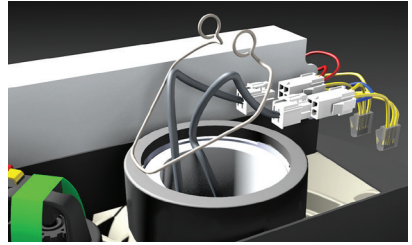

Fig. 10



Fig. 11

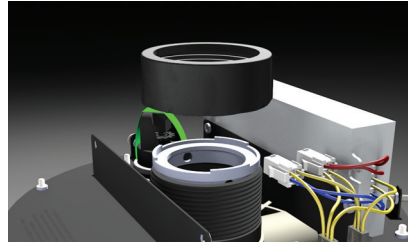
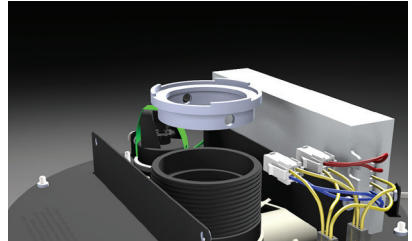

Fig. 12



8. Using protective rubber gloves and eye wear use shower/tub cleaner, CLR or equivalent, or a solution of white vinegar and water to clean the outside of the quartz tube. Remove the O-ring from the quartz tube. Fig. 14. If the inside of the quartz tube is moist or needs cleaning use the same cleaning method. The quartz tube must be completely dried and clear of residue especially near the surface where the o-ring rests before reassembly.
9. Inspect the quartz tube carefully for any cracks or chips and replace the quartz tube if any are found.

NOTICE

Do not use any other O-ring at any time for sealing the quartz tube.

Doing so can result in a leak and possible damage to your UV unit. The O-ring must be replaced after cleaning the quartz tube see page 16 for part number.

10. **All components must be completely dry and clean especially near the surface where the o-ring rests. Never use any type of lube or sealing agent.** To reinstall the quartz tube place a **new** O-ring 2 inches from the top of the outside of the quartz tube Fig. 14. Gently lower the quartz tube into the unit until the O-ring makes contact with the top of the black threaded sealing sleeve. Fig. 15
Note: Use a Paramount O-ring seal only.
11. Then place the aluminum compression washer and gasket on the quartz tube. Press down on the aluminum compression washer with an even steady pressure. Fig. 16 This will roll the O-ring into the area between the inside of the black threaded sleeve and the quartz tube. Lift aluminum washer and check to make sure it is seated evenly around the circumference of the quartz tube. Replace aluminum washer then screw on the quartz sealing aluminum nut to hand tight plus 1/2 turn.
12. Turn power on to the Ultra UV2 unit. Turn pump on to check for leaks. Confirm that there are no leaks then turn off pump and power off to the unit. Reinstall lamps, spring clip and connect to ballast(s). Reattach cover and turn power on to unit and turn pump on.



CAUTION

Do not stand over the unit when it is under pressure or when the pump is on.

Fig. 13

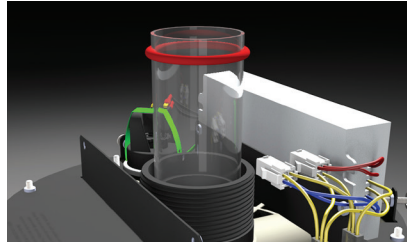

Fig. 14

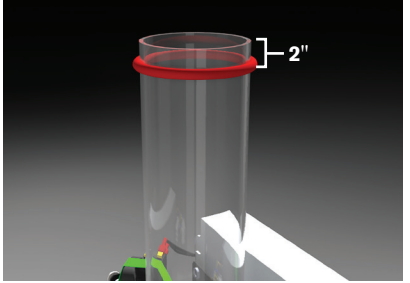

Fig. 15

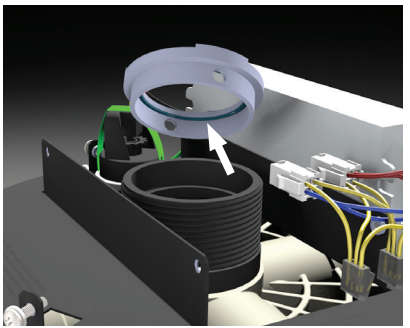
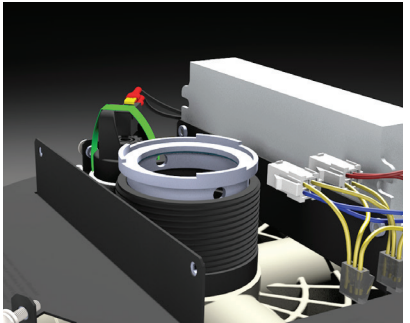

Fig. 16



SCHEDULED UV LAMP(S) REPLACEMENT

The UV lamps have a useful life of approximately 2 1/2 years and should be replaced at that time. Even though the lamp(s) may be glowing after 2 1/2 years of operation they have reached the end of their useful life.

LAMP REPLACEMENT PROCEDURE

1. Turn off all power to the ULTRA UV2 unit and all other pool equipment. Unplug the unit from its power receptacle or turn OFF the circuit breaker that is the ULTRA UV2's power source. Before proceeding to step 2 allow at least 15 minutes for the lamp(s) in the unit to cool.



DANGER

Never remove the electrical enclosure cover

without first disconnecting the power (power source) for the Ultra UV2 unit. Never remove the Ultra UV2 unit's cover without turning off the pump.

2. Remove the three screws that secure the plastic cover then remove Fig. 1.



WARNING

Before removing lamps you must wear protective

rubber gloves and safety eye wear. Do not handle a hot lamp or serious burns will occur.

NOTICE

Do not touch the glass part of the lamp as body oils will create hot spots & greatly shorten lamp life.

3. Disconnect all lamps by pressing the release tabs on connectors and gently pulling apart Fig. 8 on page 10.
4. Remove the spring clip Fig. 9 on page 10. Carefully lift the lamp assembly, including lamp holder from the quartz tube Fig. 10 on page 10. Do not pull excessively on the lamp wires.
5. Carefully remove new lamp assembly from box. Insert lamp(s) into lamp holder. lamp(s) must be aligned and seated securely in the lamp holder. Roll the black o-ring(s) up onto the ceramic end of lamp from position A to B, Fig. 18, Fig. 19. Gently insert lamps into the lower lamp retainer Fig. 17 and lower lamp assembly into unit.
6. Re-install the spring clip and re-attach the lamp connector(s) to the ballast. Note: The lamp connector(s) can only be installed one way.
7. Discard lamp(s) appropriately. Visit www.lamprecycle.org for instructions on disposal.

Fig. 17



Fig. 18

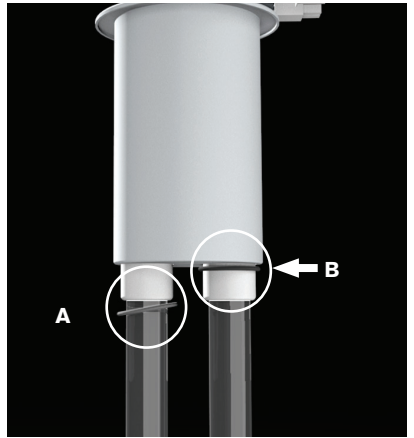

Fig. 19



FAQs

IS THE ULTRA UV2 UNIT DESIGNED FOR USE IN SALT WATER APPLICATIONS?

Yes. Paramount's Ultra UV2 units are fully compatible with all salt water environments. The quartz tube could require more frequent cleaning in a salt water environment.

DO I NEED TO TURN MY ULTRA UV2 UNIT OFF WHEN I BACKWASH MY FILTER?

No. The unit does not energize because it is not under pressure during backwashing. If you have a cartridge filter, turn off the power prior to opening the filter.

CAN WHAT SHORTEN THE LAMP LIFE OF THE ULTRA UV2 UNIT?

Multiple daily cycles can shorten lamp life. Oils from touching the lamps with bare hands.

IS THERE ANY RESIDUAL EFFECT FROM UV?

No. All of the sanitizing is done in the reactor.

CAN THE ULTRA UV2 UNIT BE MOUNTED HORIZONTALLY?

No, vertical mounting is required to maintain the weatherproof integrity of the electrical enclosure cover.

CAN THE ULTRA UV2 UNIT BE INSTALLED BELOW THE VESSEL'S WATERLINE?

Yes. But if the unit is below water level you must install a flow switch. See page 5 & 6.

CAN MULTIPLE UNITS BE USED TOGETHER FOR LARGER SYSTEMS?

Yes, you can pipe any number of Ultra UV2 units in parallel. See page 6.

MUST I USE A GFCI (GROUND FAULT CIRCUIT INTERRUPTER) WITH MY UV UNIT?

Yes. But consult your local and national electrical codes as there could be other requirements. You must use a G.F.C.I. receptacle on the 120v plug in unit. When using a 230v hardware unit, use a 15amp G.F.C.I. breaker.

TROUBLESHOOTING

IDENTIFYING AND CORRECTING SYSTEM PROBLEMS

The list below will help guide you through any problems you may have at time of initial installation or in the future. For additional assistance, contact your supplier or Paramount Pool & Spa Systems, 295 East Corporate Place, Chandler AZ 85225.

THE UV LAMP(S) WILL NOT ILLUMINATE

If this occurs upon initial start-up, the problem could be caused by a number of issues:

1. Not enough system back pressure to activate the pressure switch.
 - a. Make sure the system filter and all debris baskets are clean.
 - b. Verify that the Ultra UV2 unit is operating at minimum of 2psi, which is required to activate the pressure switch. Please note that the filter gauge does not indicate the pressure in the UV unit.
 - c. If the operating pressure of the Ultra UV2 unit is below 2psi: Restrict flow in the return manifold to create enough back pressure to activate the pressure switch. If using a variable speed or multi speed pump, be sure that the high speed setting does not create excessive system back pressure once you've adjusted the flow. Alternatively you may need to increase the low speed setting of the pump to achieve the minimum required pressure.
2. All Ultra UV2 units come with the pressure switch disabled. To ensure the pressure switch is properly enabled see page 8.
3. Check if the pressure switch is functioning properly with at least 2psi pressure at the vessel, see if the switch is open. The pressure switch can be checked by turning off the power to the unit while maintaining a pressure of 2psi or higher in the unit. With the power off and the unit under pressure disconnect the 2 leads to the pressure switch and check for continuity across the 2 pressure switch terminals. If you have continuity the pressure switch is good (closed under pressure).
Relieve the pressure from the unit and check the continuity between the 2 terminals of the pressure switch. If there is no continuity without pressure in the vessel the pressure switch is good in the open position. If the pressure switch checks good in both the open and closed positions proceed to checking the lamps.
4. Check if the UV lamp(s) has/have become disconnected from the lamp connector(s). Disconnect the power servicing the Ultra UV2 unit, remove the cover and confirm the lamp connector(s) is/are firmly locked together. At the same time, check all exposed wires for a possible loose connections. Re-establish power ONLY after the cover has been re-installed on the Ultra UV2 unit.
5. Verify that the electrical cord is plugged into an energized electrical outlet or properly connected to the power source. Test the electrical outlet. You should confirm the availability of the same power as indicated on the electrical label on your Ultra UV2 unit.

THE UV LAMP(S) IS/ARE NO LONGER ON

If this occurs after the unit has been operating successfully for a period of time.

1. One or more lamps have burned out. Replace the UV lamp(s).
2. A ballast has burned out. Contact your supplier or Paramount for assistance in obtaining a new ballast.
3. Verify that the electrical outlet where the Ultra UV2 unit is plugged into has the proper voltage and the cord is securely plugged into the outlet or connected to the power source.
4. Verify that the GFCI has not tripped. To verify the operating state of the GFCI, trip the GFCI manually and reset it manually. The GFCI should reset. If it does not, it indicates a fault to ground in the electrical circuit or the Ultra UV2 unit itself. Contact your supplier for assistance.
5. The ballasts have internal protection that will power down the lamps in the case of an electrical event. Power down the unit for 5 minutes. This will reset the internal protection. When the power is returned, the internal protection is reset.

THE WATER IS GREEN

Green water is an indication that the UV rays generated by the Ultra UV2 unit are not effective or are not being generated by the UV lamp(s).

- a. Check the lamp(s) to make sure all lamps in your system are ON (by viewing the lamp(s) through the clear viewing band on the center of the reactor. If all lamps are not ON, follow the procedures above regarding the UV lamp not lighting.
- b. Run your unit longer. If your unit is operating on a time clock, run the circulation pump longer to allow the Ultra UV2 unit to function fully.
- c. Clean the quartz tube(s).
- d. Replace the UV lamp(s) nearing the 2 1/2 year useful lamp life. After 2 1/2 years of operation, the UV lamp(s) are only 80% as effective as when new. This is normal for all long life low-pressure type UV lamps, which are the longest useful life lamps available for this type of application.
- e. If your Ultra UV2 unit is installed on a swimming pool, shock the pool with the sanitizing chemical you normally use and balance the pool water as per your chemical manufacturer's specifications.
- f. Your unit is not sized for the flow and duration specific to your pool.

THE GFCI HAS TRIPPED

If you have installed a GFCI on your Ultra UV2 application, the GFCI will protect the Ultra UV2 unit and any other equipment on the same electrical circuit from any fault to ground, the same as the electrical breaker protects the total electrical circuit from a short. When the GFCI trips, it is an indication that there is an electrical problem that must be corrected to provide a safe operating environment for your installation. Follow the instructions of the GFCI manufacturer for more information on correcting the issue if the problem is with the GFCI.

- a. If you suspect that the problem is with the Ultra UV2 unit, disconnect the Ultra UV2 unit from the electrical receptacle. Reset the GFCI at the breaker panel or at the receptacle. If the GFCI does not reset, have the G.F.C.I. replaced by a licensed electrician. If the GFCI does reset, first run the circulation pump, and if no GFCI trip is encountered, plug the Ultra UV2 unit into the electrical receptacle and make sure the pump is ON. If the GFCI trips, it is an indication that there is a ground fault inside the Ultra UV2 unit. Follow the instructions previously given for opening the electrical enclosure cover and inspecting the Ultra UV2 unit. Call a qualified technician.
- b. If water is present inside the electrical enclosure cover, it will trip the GFCI. Following instructions given previously to remove the quartz tube(s), inspect for quartz tube cracks or breakage or for a bad quartz tube seal. Replace the quartz tube if it is cracked or broken. If not reset it. See page 4.
- c. If the Ultra UV2 unit trips when performing the test noted in Sec. (a) above, you can check to determine if a UV lamp is the GFCI trip cause by unplugging the individual lamp from the lamp connector, then place the electrical enclosure cover back on the Ultra UV2 unit and power up the circulation pump. If the GFCI does not reset, then the problem is either with the remaining lamp(s) or with a ballast. Remove all the lamp connectors and reset the GFCI after replacing the electrical enclosure. If the GFCI still trips, unplug all ballasts. If the GFCI resets, then plug in first one ballast, and if your unit has two ballasts, then the second ballast after the first ballast has been tested. If either ballast trips the GFCI, then replace that ballast. Refer to page 16 for the proper ballast part number. Reset the GFCI and if it does not trip, attach the electrical plug to a UV lamp. (One at a time if multiple lamps are present in your Ultra UV2 unit.) If it trips with the lamp lit, it indicates that a UV lamp is causing the fault to ground. Replace the UV lamp.

THE ULTRA UV2 UNIT MAKES NOISE WHEN OPERATING

This is an indication of the Ultra UV2 unit not being properly attached to a firm mounting base of concrete using bolts (not supplied) placed through the mounting holes in the Ultra UV2 unit base. Attach the Ultra UV2 unit correctly to a firm base as described in page 4.

WATER IS DRIPPING FROM THE ELECTRICAL ENCLOSURE COVER

Water exiting the unit through the electrical enclosure cover can be attributed to either (a) a bad quartz tube seal, or (b) a broken or cracked quartz tube. Check the quartz tube seal and quartz tube as instructed in page 4.

SPECIFICATION NOTICE

Due to Paramount's commitment to continual product improvement, all product descriptions or specifications noted herein are subject to change without notice.

LIMITED WARRANTY

Ultra UV2 water sanitizers are covered under a **2 year Limited Warranty**.

Go to www.1paramount.com/downloads/warranties/UltraUV2Warranty.pdf to view warranty.

PROPER INSTALLATION OF THE ULTRA UV2 IS ESSENTIAL. FOR QUESTIONS, PLEASE CALL PARAMOUNT AT 1.800.621.5886 OR CONTACT YOUR REGIONAL REPRESENTATIVE. PLEASE FOLLOW ALL LOCAL CODES AND POOL SAFETY GUIDELINES.

HEAD LOSS CURVES

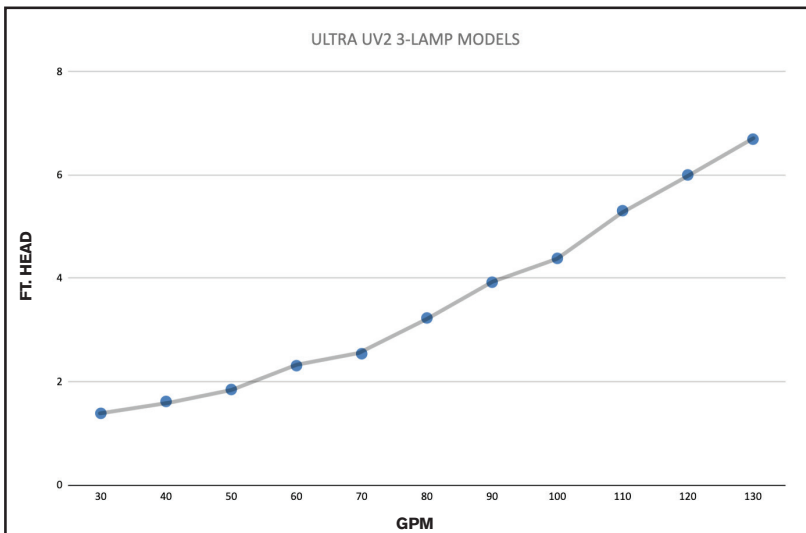
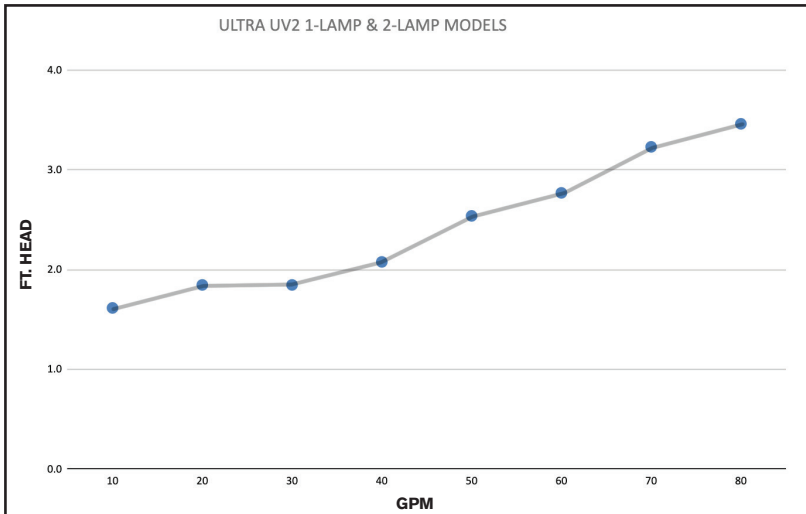

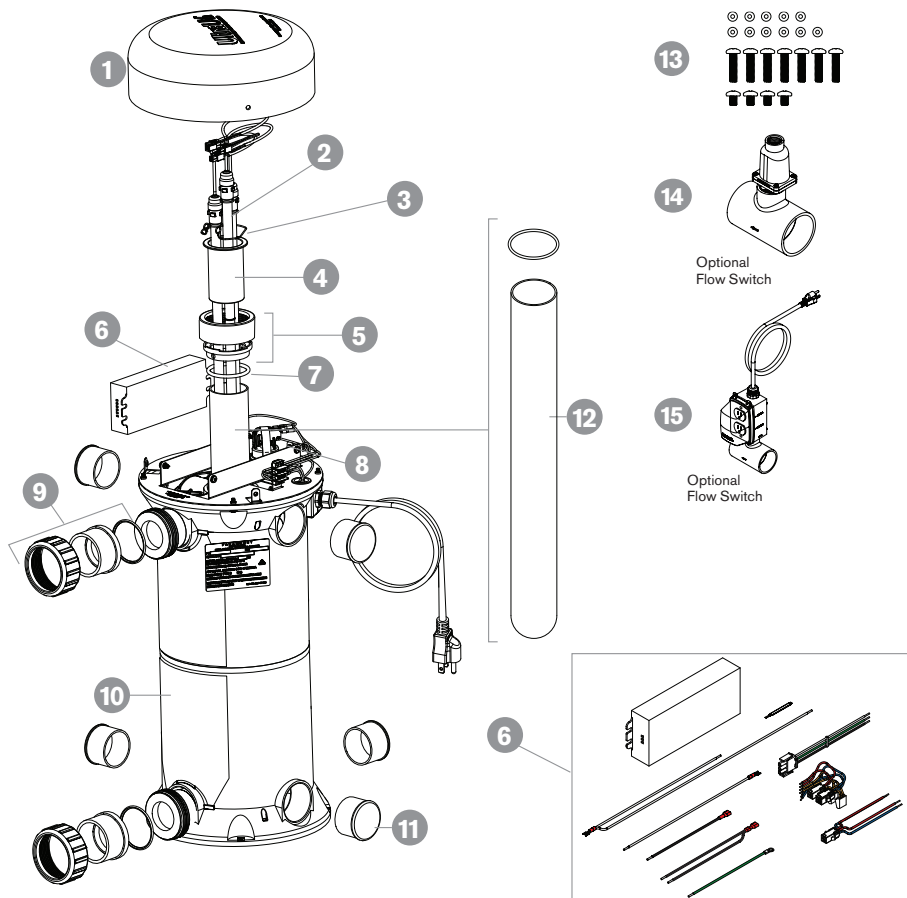

ULTRA UV2 PART NUMBERS

	Paramount Part#	Description
1	005-422-2009-11	Cover
2	005-422-9017-00	UV Lamp
3		Spring Clip
4		UV Lamp Holder
5	005-422-5102-00	Quartz Tube Sealing Assembly
6	005-422-9030-00	Universal Ballast Replacement Kit
7	005-422-5103-00	Quartz Tube Seal O-Ring, 3 Pack
8	005-422-2009-10	Pressure Switch
9	005-422-2009-06	2" Union Kits
10	005-422-3000-00	Replacement Housing
11	005-422-2009-08	2" Blanking Plug
12	005-422-2009-09	Quartz Tube With Seal Kit
13	005-422-2009-04	Screw Kits
14	004-402-0010-00	Flow Switch 1 1/2" or 2" (Optional)
15	004-421-3824-00	Plug-in, 120v flow switch for 2" pipe (Optional)