

CT12-125X 12V 125Ah (10hr) Sealed Lead Acid (SLA) Battery

The rechargeable batteries are lead-lead dioxide systems. The dilute sulfuric acid electrolyte is absorbed by separators and plates and thus immobilized. Should the battery be accidentally overcharged producing hydrogen and oxygen, special one-way valves allow the gases to escape thus avoiding excessive pressure build-up. Otherwise, the battery is completely sealed and is, therefore, maintenance-free, leak proof and usable in any position.



Battery Construction

Component	Positive plate	Negative plate	Container	Cover	Safety valve	Terminal	Separator	Electrolyte
Raw material	Lead dioxide	Lead	ABS	ABS	Rubber	Copper	Fiberglass	Sulfuric acid

General Features

- Absorbent Glass Mat (AGM) technology for efficient gas recombination of up to 99% and freedom from electrolyte maintenance or water adding.
- Not restricted for air transport-complies with IATA/ICAO Special Provision A67.
- UL-recognized component.
- Can be mounted in any orientation.
- Computer designed lead, calcium tin alloy grid for high power density.
- Long service life, float or cyclic applications
- Maintenance-free operation.
- Low self discharge.
- Valve Regulated Lead Acid (VRLA) battery
- V0 Class Flame-Retardant ABS (UL94V-0) container and cover

Dimensions and Weight

Length(mm / inch)	550 / 21.65
Width(mm / inch)	110 / 4.33
Height(mm / inch)	288 / 11.34
Total Height(mm / inch)	288 / 11.34
Approx. Weight(Kg / lbs)	39.0 / 85.8

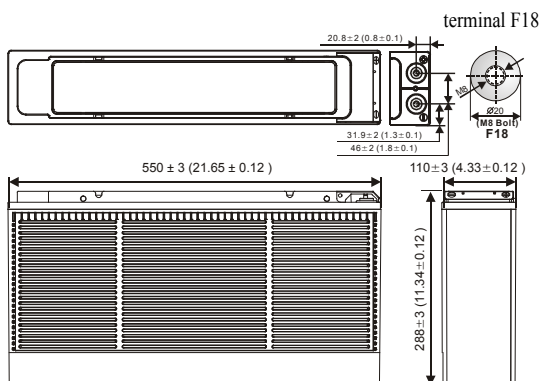

Performance Characteristics

Nominal Voltage	12V
Number of cell	6
Design Life	12 years
Nominal Capacity 77°F(25°C)	
10 hour rate (12.5A, 10.8V)	125Ah
5 hour rate (21.25A, 10.2V)	106.3Ah
1 hour rate (75A, 9.6V)	75Ah
Internal Resistance	
Fully Charged battery 77°F(25°C)	7mOhms
Self-Discharge	
3% of capacity declined per month at 25°C (average)	
Operating Temperature Range	
Discharge	-20~60°C
Charge	-10~60°C
Storage	-20~60°C
Max. Discharge Current 77°F(25°C)	1,250A(5s)
Short Circuit Current	1700A
Charge Methods: Constant Voltage Charge 77°F(25°C)	
Cycle use	14.4-14.8VPC
Maximum charging current	30A
Temperature compensation	-30mV/°C
Standby use	13.5-13.8VPC
Temperature compensation	-20mV/°C

Discharge Rates in Watts to Various End Voltage at 25°C(77°F)

End Voltage	1.85V	1.80V	1.75V	1.70V	1.65V	1.60V
15 min	268	328	370	397	413	422
30 min	159	196	220	236	246	251
60 min	136	146	152	155	157	159
120 min	77.2	82.8	85.2	87.2	88.5	89.2
180 min	59.3	63.5	65.3	66.7	67.7	68.2
300 min	40.8	43.0	44.5	45.7	46.5	46.8
600 min	24.5	25.5	26.3	27.0	27.3	27.5
1200 min	12.6	13.2	13.5	13.8	14.0	14.1

Discharge Rates in Amperes to Various End Voltage at 25°C(77°F)

End Voltage	1.85V	1.80V	1.75V	1.70V	1.65V	1.60V
15 min	153	188	213	226	235	241
30 min	89.2	108	121	129	134	137
60 min	70.4	75.9	77.8	79.5	80.8	81.6
120 min	38.2	42.3	44.0	45.3	45.2	45.8
180 min	27.7	30.8	31.9	32.8	33.5	34.0
300 min	19.9	21.3	22.1	22.6	22.9	23.1
600 min	11.8	12.6	13.0	13.3	13.5	13.6
1200 min	6.42	6.63	6.72	6.79	6.85	6.89

(Note)The above characteristics data are average values.

DENA ENGINEERING CO.,LTD.

185/1 Wongsawang Road, Wongsawang, Bangsue, Bangkok 10800 THAILAND

Tel. 02-587-7780, 02-910-9600 Fax. 02-587-1624 e-mail: dena@dena.co.th www.dena.co.th

CT12-125X 12V 125Ah (10hr) Sealed Lead Acid (SLA) Battery

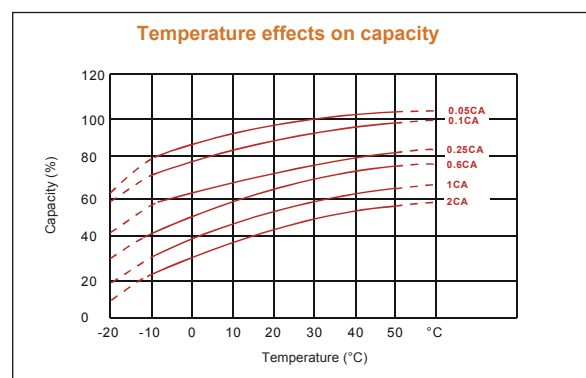
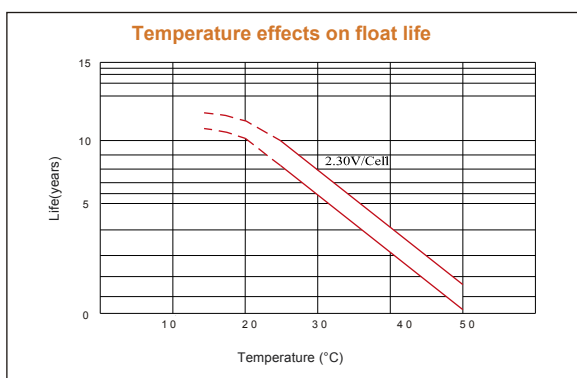
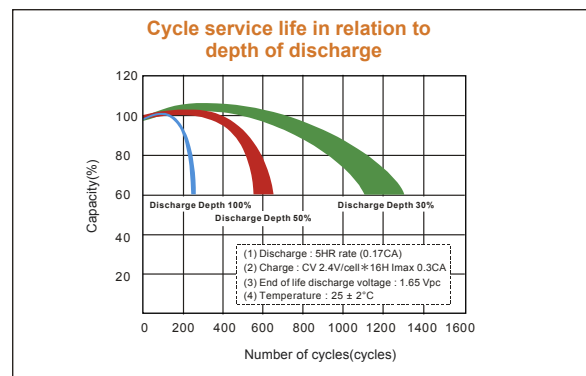
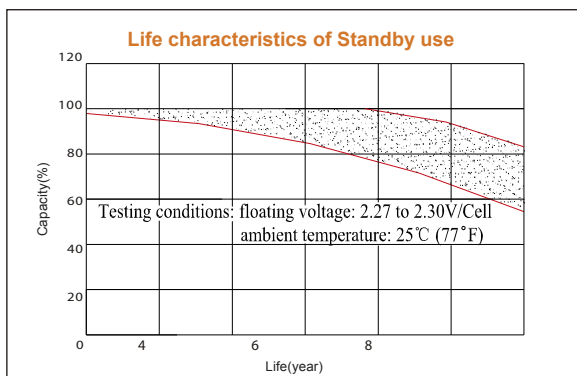
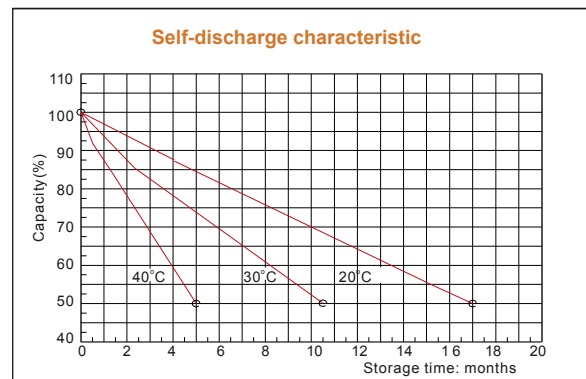
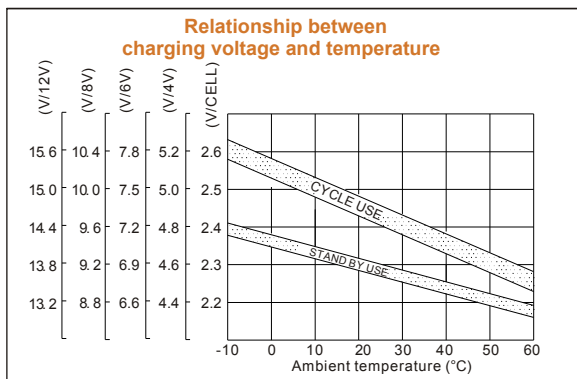
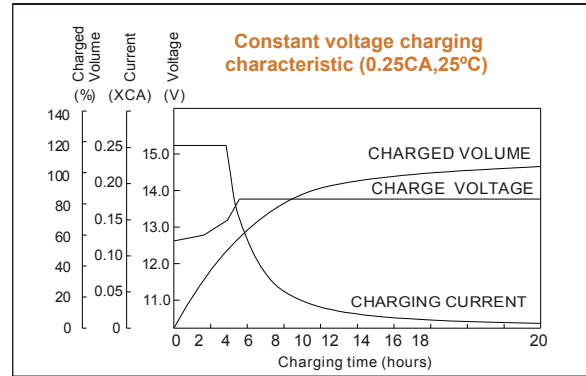
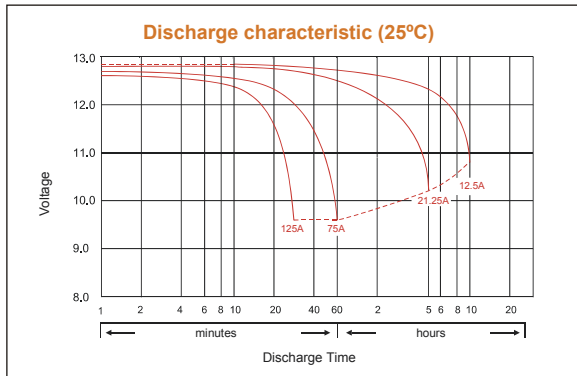

DENA ENGINEERING CO.,LTD.

185/1 Wongsawang Road, Wongsawang, Bangsue, Bangkok 10800 THAILAND

Tel. 02-587-7780, 02-910-9600 Fax. 02-587-1624 e-mail: dena@dena.co.th www.dena.co.th