

UCHIDA DOUBLE-HEAD SHEET COUNTER COUNTRON TWIN TOUCH



Coutron Twin Touch

The ideal solution for ensuring professional security in paper counting.

Uchida Coutron Twin Touch is the professional double head paper counting machine. Its accurate pin & blade counting mechanism, proven by thousands of users for several decades enables the operator to count a pile of sheet by just a press of a button. Twin head counting mode reduce labor time by counting 2 corners of a paper pile simultaneously. This is very helpful when counting security prints such as bank notes, cash vouchers etc. Both towers are capable to insert tab tapes between papers, every 2-1000 sheets or at designated numbers. This enables the Coutron Twin Touch to batch the papers with checking the number.

Ideal for...



Security printer



Government printing facility



Manufacturer

Best features



Intuitive touch screen operation & settings.

The large touch screen control panel makes setting and operation easy. Number of counted sheets, total count are clearly indicated. Tab tape insertion setting is also straightforward.

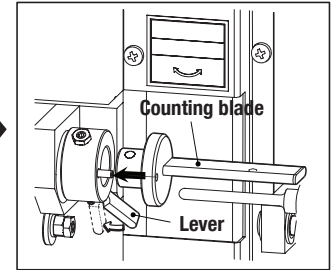
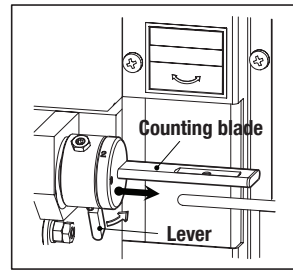

Quick counting blade change without a tool.

By exchanging air suction counting blades, the Coutron Twin Touch can count a wide range of stock from 22gsm up to 256gsm in paper weight. Exchanging blades is quick and tool-free.



Increased counting speed. The same great accuracy.

The maximum counting speed of the Coutron Twin Touch is 2,500sheets/min, 14% faster than the previous model. The counting accuracy remains at the highest level in its class.

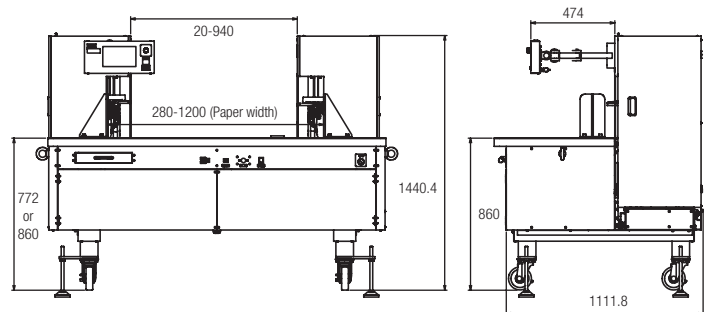

Japanese engineering. Robust machine body.

The Coutron Twin Touch is designed and made in Japan. It's robust body ensures its great accuracy for a long time.

Specifications

Machine type	Standalone, with double counting head
Counting mechanism	Pin & blade system
Counting speed	0-2,500sheets/min.
Countable paper quality	22-256gsm
Countable paper size	Single mode: (Stationary tower) 100x130mm - 1,200x800mm (Movable tower) 150x200mm - 1,200x800mm Twin mode: 80x130mm - 1,200x800mm
Stacking capacity	Up to 300mm* subject to change depending on paper weight
Tab tape insertion	Yes / Every 2 to 1,000sheets / Tape roll: 6mmx100m
Height of work table	772mm or 860mm (To be selected)
Area of work table	1,910x680mm
Power source	110V, 120V, 220V, 230V or 240V, 50/60Hz, single phase
Power consumption	850W
Dimensions	1,970(W)x1,180(D)x1,440(H)mm
NET weight	500kg



Counting blades

Inserting tape roll

Blade	Descriptions
Suction blade No.1	For 22-52 gsm, Copy paper, Pure-white rolls, Fine quality paper, NCR paper etc.
Suction blade No.2	For 52-105 gsm, Fine quality paper, NCR paper, OCR paper, Form paper, Tucked paper, Coated paper etc.
Suction blade No.3	For 105-157 gsm, Fine quality paper, OCR paper, COated paper, Art paper, Kent paper etc.
Suction blade No.4	For 157-256 gsm, Fine quality paper, OCR paper, Coated paper, Art post paper, Kent paper etc.

Production rates are based on optimal operating conditions.
As part of our continuous product improvement program, specifications are subject to change without notice.