

VENN Model KT-5 type strainer

This straight-type strainer revolutionizes the concept of strainers. It eliminates the problems associated with conventional strainers, such as installation, maintenance, and pressure loss. Made of stainless steel, it boasts exceptional corrosion resistance and durability. Its small diameter and compact design make it ideal for equipment integration. It features a unique structure that allows for easy attachment and detachment of the net. (Patented)

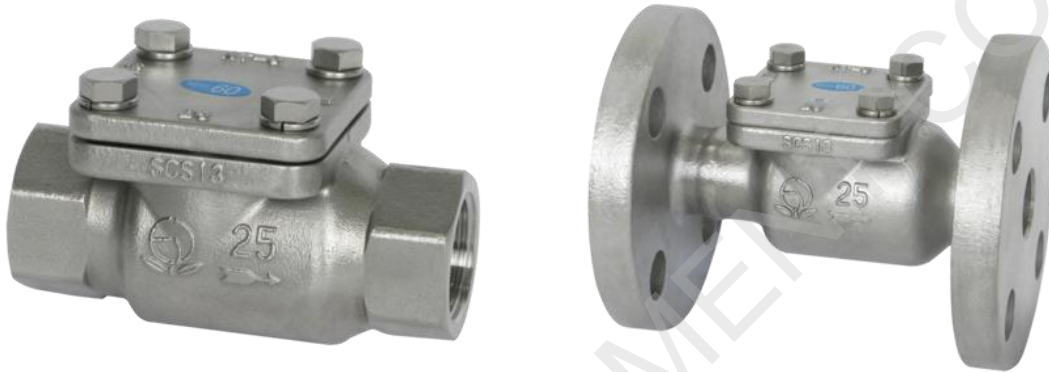

A new-concept (Straight Type) strainer that is completely different from the conventional products. Allow easy maintenance, installation, and reduced pressure loss. Stainless steel parts that are corrosion resistant and durable. Small and compact strainer allows easy integration into machines. Unique design for easy removal of net.

SPECIFICATIONS

Type	Screwed		Flanged	
Model name	KT-5	KT-5W	KT-5F	KT-5FW
Code name	KT5-D	KT5W-D	KT5F-D	KT5FW-D
Applicable fluid	Steam, gases & liquids	Liquids & gases	Steam, gases & liquids	Liquids & gases
Fluid temperature	Max. 150°C	Max. 90°C	Max. 150°C	Max. 90°C
Applicable pressure	Max. 2.0MPa		Max. 1.0MPa	
End connection	Screwed JIS Rc		Flanged JIS 10KFF	
Materials	Body and Cover (Stainless steel), Net (Stainless steel)			
Mesh	60 Mesh	20,40,80 or 100 Mesh	60 Mesh	20,40,80 or 100 Mesh
Allowed pressure differential	Max. 0.1MPa			
Pressure test	Hydraulic 3.0MPa		Hydraulic 1.5MPa	

CONSTRUCTION

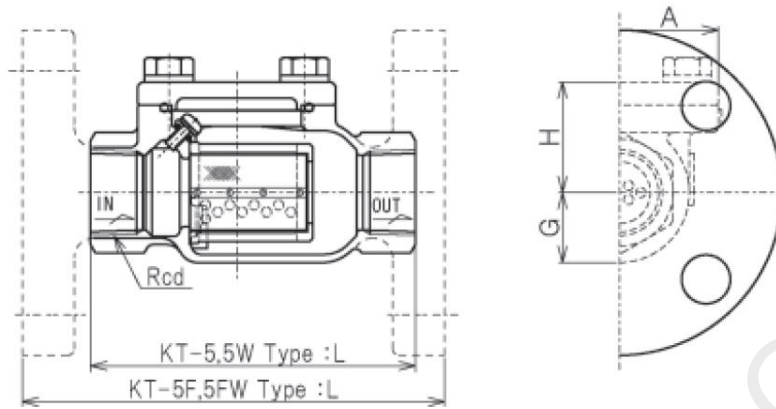

DIMENSION

KT-5, 5W Type

Size	d	A (mm)	B (mm)	C (mm)	Mass (kg)
15 (1/2")	1/2"	50	34	32	0.21
20 (3/4")	3/4"	53	40	38	0.28
25 (1")	1"	60	48	46	0.5
32 (1 1/4")	1 1/4"	63	65	55	1
40 (1 1/2")	1 1/2"	65	75	63	1.4
50 (2")	2"	70	110	95	3.4

KT-5F, 5FW Type

Size	L	G	H	A	Mass(kg)
15(1/2")	120	17	35	50	1.8
20(3/4")	130	22	43	61	2.5
25(1")	150	26	46	66	3.8
32(1 1/4")	170	32	58	80	5.3
40(1 1/2")	190	38	66	94	6.1
50(2")	220	45	77	104	8.3

PRESSURE LOSS CHART (60 mesh)

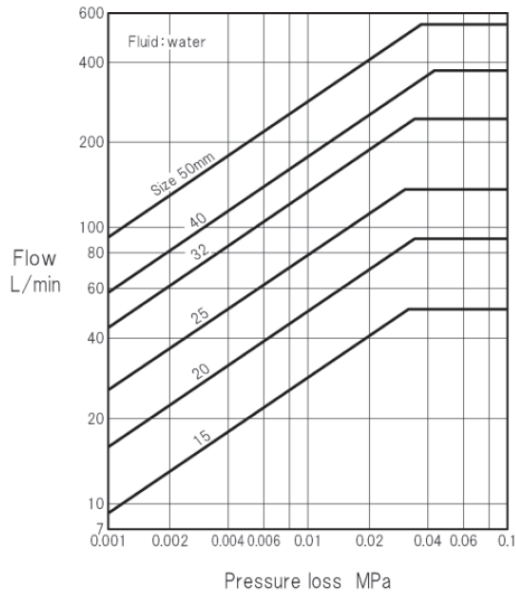

MULTIPLIER LIST

Mesh	Multiplier
20	0.9
40	0.95
80	1.05
100	1.1

Note: The pressure loss for each mesh number can be calculated by multiplying pressure loss determined using the above chart and a multiplier listed.

KRUNGTHAI EQUIPMENT CO., LTD.