



www.kdhoist.com

*Technology, Efficiency, Handiness
All There are possible at KUK-DONG HOIST Co., Ltd.'s*

MINI ELECTRIC CHAIN HOIST

MN-125/250(125/250kgs)

- Single Phase (220V)
- Mini Size & Weight (14kgs)
- Push Button (Easy to Use)
- Brushless DC Motor
- Speed Regulation Dial (2.0 ~ 14.0 M/MIN.)
- Mechanical Brake & Slip Clutch
- High Tension Load Chain (4.0mm)



MINI Electric Chain Hoist Exploded View

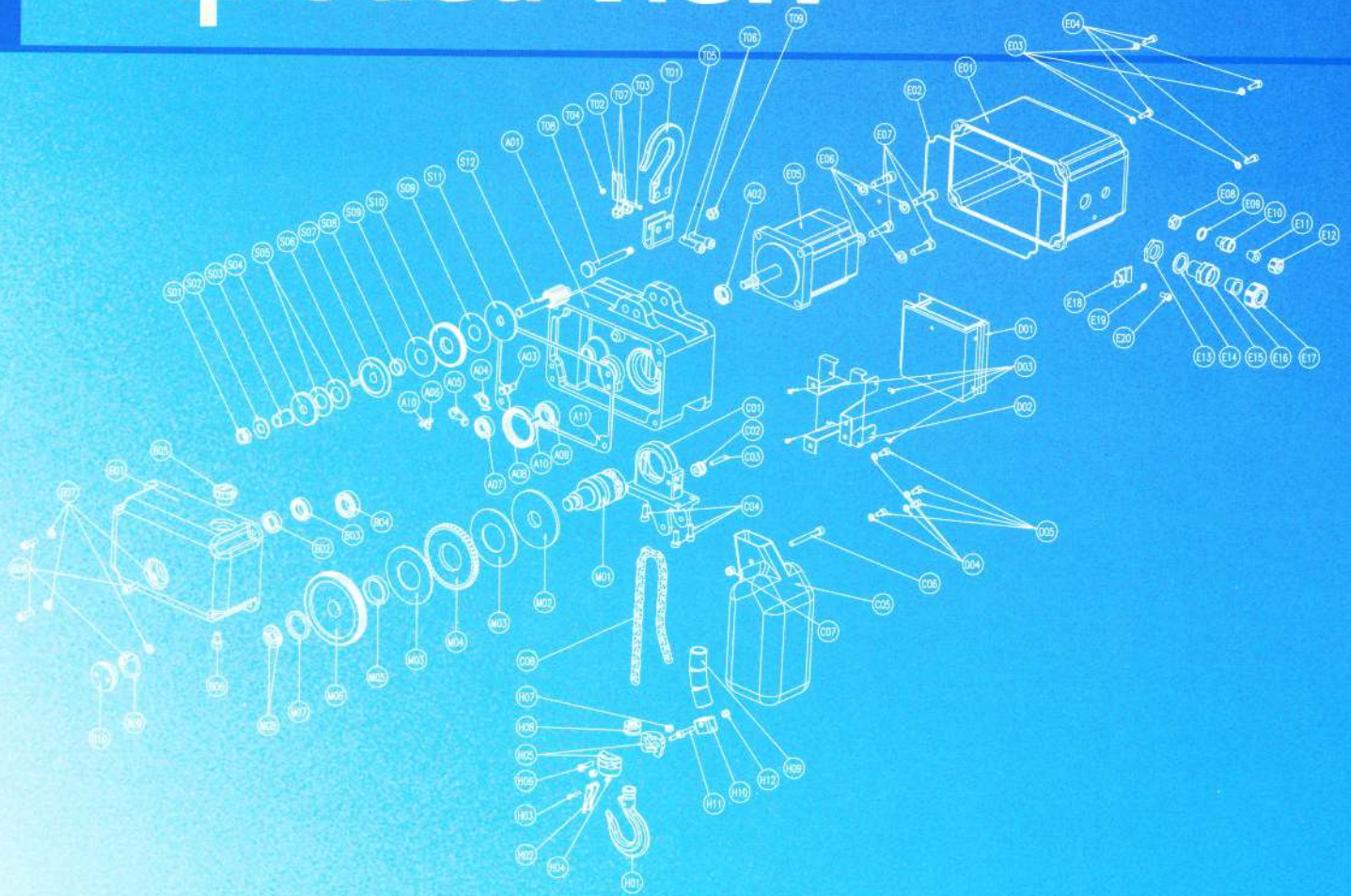

SLIP CLUTCH PART

| NO. | DESCRIPTION | MATERIAL | QTY | SIZE | REMARK |
|-----|-----------------------|----------|-----|-----------------|-------------------|
| S01 | LOCK NUT | PUR | 1 | M12 | |
| S02 | TORQUE CONTROL WASHER | SS41 | 1 | T3x17x2x38 | |
| S03 | SLIPRING | S43C | 1 | #12x11.5x25L | |
| S04 | SPRING LOCK | S43C | 1 | #4x5x11.5x25L | |
| S05 | SPRING SPRING | PUR | 2 | #4x5x25x4x2.75H | |
| S06 | WET | PUR | 1 | 38.4x4x18 | |
| S07 | PRESSURE PLATE B | SS41 | 1 | T12x45x4x12 | |
| S08 | WOMEN | BC3 | 1 | #31x41.7x35L | |
| S09 | WASHER | WASHER | 2 | T14x25.6x21 | for FRICTION GEAR |
| S10 | FRIBION GEAR | S43C | 1 | T14x25.6x21 | |
| S11 | PRESSURE PLATE A | SS41 | 1 | T14x25.6x12 | |
| S12 | DR. FRIBION | SCM418 | 1 | #24.1x27.5 | |

MAIN BODY PART

| NO. | DESCRIPTION | MATERIAL | QTY | SIZE | REMARK |
|-----|---------------|----------|-----|-----------------|---------------|
| A01 | MAIN BODY | ACBB | 1 | 250kg | ST : 2.786kg |
| A02 | DR. WASHER | PUR | 1 | #15x42x2x7 | |
| A03 | WASHER | S43C | 1 | #4x11x11.5x25L | |
| A04 | WASHER SPRING | PUR | 1 | #1.5x3 | |
| A05 | WASHER | S43C | 1 | | |
| A06 | WASHER SPRING | PUR | 1 | #2 | STB-59 |
| A07 | WASHER | PUR | 1 | #12x42x4x8 | 800122 |
| A08 | DR. WASHER | PUR | 1 | #4x3x45x5x8 | |
| A09 | WASHER | PUR | 1 | #17x43x10 | 800322 |
| A10 | SPRING PIN | PUR | 2 | #2x20 | |
| A11 | WASHER | #4-20x25 | 1 | T12x24.4x12.7.8 | for ISAR CASE |

TOP HOOK PART

| NO. | DESCRIPTION | MATERIAL | QTY | SIZE | REMARK |
|-----|----------------------|----------|-----|--------------|--------|
| T01 | TOP HOOK | S43C | 1 | 250kg(125kg) | |
| T02 | SAFETY LATCH | SS41 | 1 | 5mm | |
| T03 | PIN HEAD SCREW | PUR | 1 | M3x20 | |
| T04 | LOCK NUT | PUR | 1 | M3 | |
| T05 | TOP WASHER | SS41 | 4 | 250kg(125kg) | |
| T06 | SOCKET HEAD CAP BOLT | PUR | 2 | M6x30 | |
| T07 | LOCK NUT | PUR | 2 | M6 | |
| T08 | TOP HOOK PIN | S43C | 1 | #32x4x6L | |
| T09 | LOCK NUT | PUR | 1 | M6 | |

MECHANICAL BRAKE & LOAD SHEAVE PART

| NO. | DESCRIPTION | MATERIAL | QTY | SIZE | REMARK |
|-----|------------------|----------|-----|----------------|--------|
| M01 | LOAD SHEAVE | S43C | 1 | #4x20x40 | |
| M02 | PRESSURE PLATE D | SS41 | 1 | F7x48x18x40 | |
| M03 | WASHER | WASHER | 2 | 12x48x14x30 | |
| M04 | WASHER | BC3 | 1 | #31x41.7x35L | |
| M05 | WASHER | S43C | 1 | #4x3x45x5x8 | |
| M06 | LOAD SHEAVE | S43C | 1 | #10x40x20x1.5T | |
| M07 | WASHER | WASHER | 1 | 12x48x14x30 | |
| M08 | WASHER | SCM21 | 2 | T4.5x48x18x12 | |

REDUCER CASE PART

| NO. | DESCRIPTION | MATERIAL | QTY | SIZE | REMARK |
|-----|----------------------|----------|-----|------------|-----------------------|
| R01 | REDUCER CASE | ACBB | 1 | 250kg | ST : 1.814kg |
| R02 | DR. WASHER | PUR | 1 | #17x43x2x7 | |
| R03 | WASHER | PUR | 1 | #12x42x4x8 | 800322 |
| R04 | WASHER | PUR | 1 | #17x43x10 | 800322 |
| R05 | DR. WASHER | PUR | 1 | PT 1.5 | PLASTIC |
| R06 | DR. WASHER | PUR | 1 | M6x10 | |
| R07 | SPRING LOCK WASHER | PUR | 4 | M5 | |
| R08 | SOCKET HEAD CAP BOLT | PUR | 4 | M6x20 | |
| R09 | DR. WASHER | PUR | 1 | #2x2x3.5 | for WASHER CONTROL OP |
| R10 | TORQUE CONTROL OP | S43C | 1 | #48x13.5 | |

BOTTOM HOOK PART

| NO. | DESCRIPTION | MATERIAL | QTY | SIZE | REMARK |
|-----|----------------------|----------|-----|---------------|-------------|
| B01 | BOTTOM HOOK | S43C | 1 | 250kg(125kg) | |
| B02 | SAFETY LATCH | SS41 | 1 | 5mm | with SPRING |
| B03 | PIN HEAD SCREW | PUR | 1 | M3x20 | |
| B04 | LOCK NUT | PUR | 1 | M3 | |
| B05 | WASHER | S43C | 2 | 250kg(125kg) | with WASHER |
| B06 | SOCKET HEAD CAP BOLT | PUR | 2 | M6x30 | |
| B07 | LOCK NUT | PUR | 2 | M6 | |
| B08 | DR. WASHER | WASHER | 1 | #22x12.5 | with WASHER |
| B09 | WASHER | WASHER | 2 | #31.7x2.8x25L | |
| B10 | WASHER | S43C | 1 | 250kg(125kg) | with WASHER |
| B11 | SOCKET HEAD CAP BOLT | PUR | 1 | M6x20 | |
| B12 | LOCK NUT | PUR | 1 | M6 | |

CHAIN GUIDE PART

| NO. | DESCRIPTION | MATERIAL | QTY | SIZE | REMARK |
|-----|------------------------|----------|-----|-------------|--------------|
| C01 | CHAIN GUIDE | SC21 | 1 | #4 | |
| C02 | CHAIN GUIDE ROLLER | SC21 | 1 | #12x12 | |
| C03 | CHAIN GUIDE ROLLER PIN | SC21 | 1 | #4x30 | |
| C04 | SOCKET HEAD CAP BOLT | PUR | 3 | M6x10 | with S/W |
| C05 | CHAIN BRACKET | PLASTIC | 1 | 30x30x18x4L | L/W / Max.2m |
| C06 | SOCKET HEAD CAP BOLT | PUR | 1 | M6x20 | |
| C07 | LOCK NUT | PUR | 1 | M6 | |
| C08 | LOAD CHAIN | A511824 | - | #4x15 | |

CONTROL PART

| NO. | DESCRIPTION | MATERIAL | QTY | SIZE | REMARK |
|-----|----------------------|----------|-----|------------|----------------|
| E01 | CONTROL PART COVER | ACBB | 1 | 250kg | ST : 1.124kg |
| E02 | DR. WASHER | PUR | 1 | #41.6x40x5 | for CONTROL OP |
| E03 | SPRING LOCK WASHER | PUR | 4 | M5 | |
| E04 | SOCKET HEAD CAP BOLT | PUR | 4 | M5x15 | |
| E05 | SLIPRING | PUR | 1 | 750W | |
| E06 | SPRING LOCK WASHER | PUR | 4 | M6 | |
| E07 | SOCKET HEAD CAP BOLT | PUR | 4 | M6x30 | |
| E08 | LOCK NUT | PUR | 1 | M6x11-5A | |
| E09 | WASHER | PUR | 1 | M6x11-5A | |
| E10 | CABLE GLAND BODY | PUR | 1 | M6x11-5A | |
| E11 | SLIPRING | PUR | 1 | M6x11-5A | |
| E12 | CABLE GLAND CAP | PUR | 1 | M6x11-5A | |
| E13 | LOCK NUT | PUR | 1 | M6x11-5A | |
| E14 | WASHER | PUR | 1 | M6x11-5A | |
| E15 | CABLE GLAND BODY | PUR | 1 | M6x11-5A | |
| E16 | SLIPRING | PUR | 1 | M6x11-5A | |
| E17 | CABLE GLAND CAP | PUR | 1 | M6x11-5A | |
| E18 | CABLE CLIP | SS41 | 1 | M4x20 | |
| E19 | SPRING LOCK WASHER | PUR | 1 | M5 | |
| E20 | SOCKET HEAD CAP BOLT | PUR | 1 | M6x10 | |

DRIVER(CONTROLLER) PART

| NO. | DESCRIPTION | MATERIAL | QTY | SIZE | REMARK |
|-----|----------------------|----------|-----|-------|-------------|
| D01 | BLDC DRIVER | - | 1 | | |
| D02 | DRIVER PLATE | SS41 | 1 | | with WASHER |
| D03 | PIN HEAD SCREW | PUR | 4 | M3x10 | |
| D04 | SPRING LOCK WASHER | PUR | 4 | M3 | |
| D05 | SOCKET HEAD CAP BOLT | PUR | 4 | M6x10 | |

PUSH BUTTON PART

| NO. | DESCRIPTION | MATERIAL | QTY | SIZE | REMARK |
|-----|--------------------|----------|-----|-----------------|-------------------|
| P01 | PUSH BUTTON | PUR | 1 | | |
| P02 | CONTROL CABLE | NET | 1 | 0.75x4-RC | |
| P03 | LAMP-ORION | PUR | 1 | LED : 45 | |
| P04 | LAMP-RED | PUR | 1 | LED : 45 | |
| P05 | SPEED CONTROL WASH | PUR | 1 | 10K | VOLUNT RESISTANCE |
| P06 | BUTTON-UP | PUR | 1 | | |
| P07 | BUTTON-DOWN | PUR | 1 | | |
| P08 | PUSH CABLE | PUR | 1 | NO. 14 110/220V | |

MINI Electric Chain Hoist MN/MNP Type



MN Type

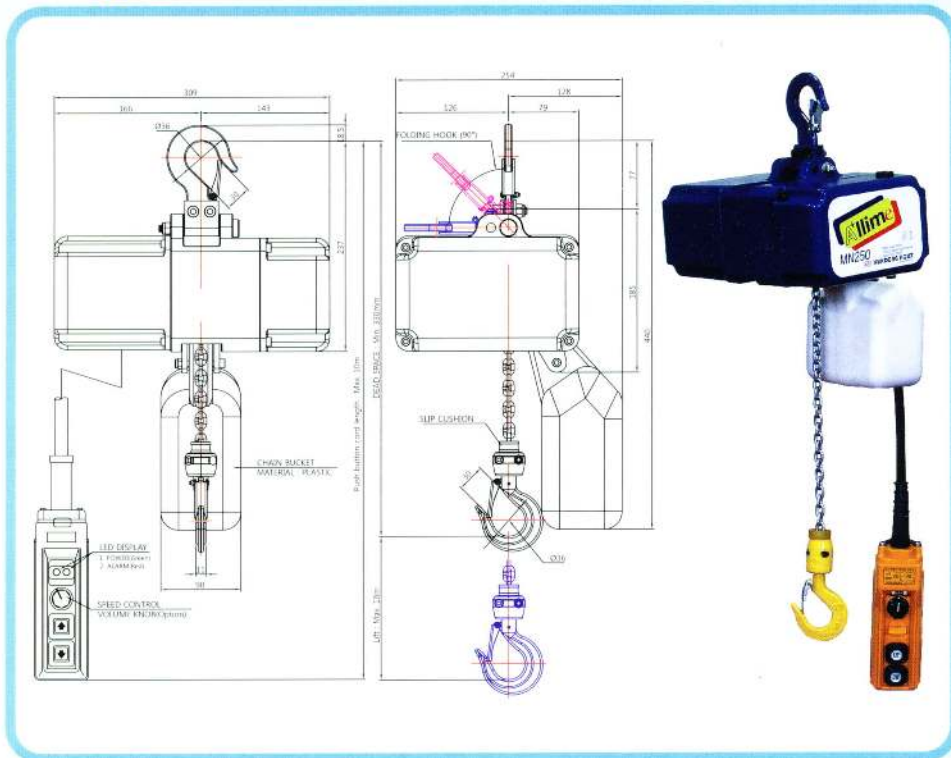

| | | |
|--------------------------|--------------------------------|----------------------------|
| MODEL | MN-250 | |
| CAPACITY | 250 kg | |
| TEST LOAD | 312 kg | |
| LIFT | Max. 10m | |
| HOISTING | MOTOR | BLDC 750w |
| | SPEED | 12m/min |
| | SPEED CONTROL | 0~15m/min(Variable:Option) |
| SAFETY DEVICE | MECHANICAL BRAKE & SLIP CLUTCH | |
| POWER SOURCES | AC 1Ø 220V 50/60Hz | |
| OPERATION METHOD | PUSH BUTTON SWITCH TYPE ON FL | |
| LED DISPLAY | POWER(green) & ALARM(red) | |
| OPERATING TEMPERATURE | -20°C ~ 50°C | |
| International Protection | 54 | |
| LOAD CHAIN | Ø4.0 x P12.0mm x 1fall | |
| PAINT COLOR | 0.4 PB 4.2/5.6 | |
| NET WEIGHT | Max. 19 kg | |

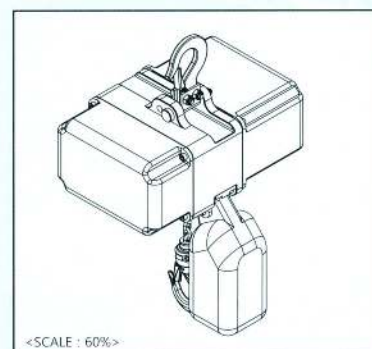

MNP Type

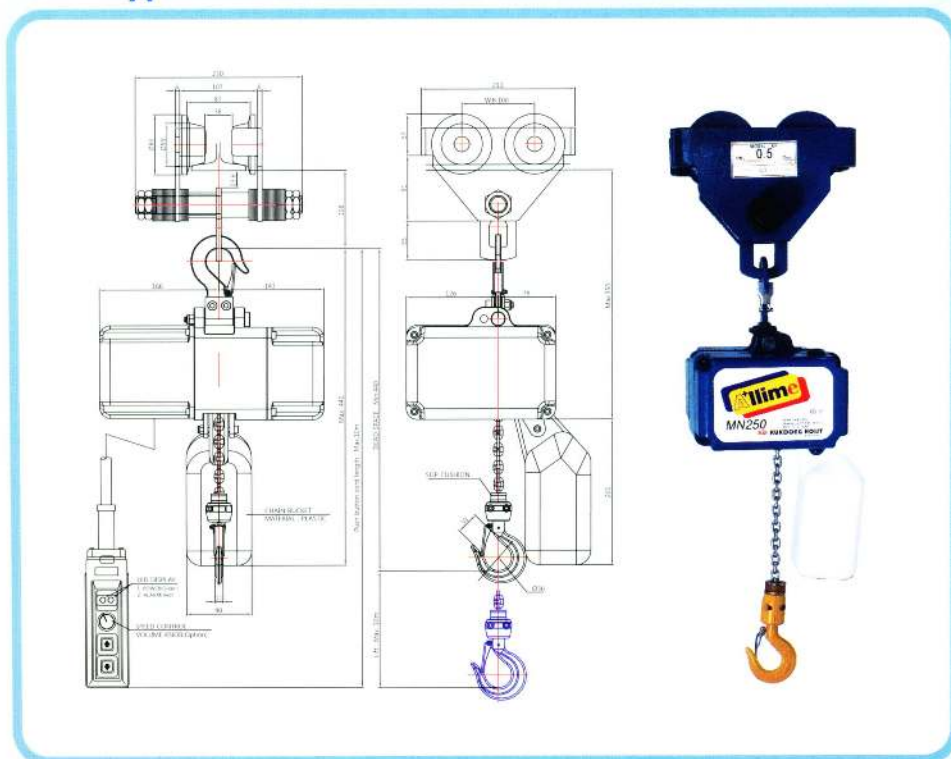

| | | |
|--------------------------|--------------------------------|----------------------------|
| MODEL | MN-250 | |
| CAPACITY | 250 kg | |
| TEST LOAD | 312 kg | |
| LIFT | Max. 10m | |
| HOISTING | MOTOR | BLDC 750w |
| | SPEED | 12m/min |
| | SPEED CONTROL | 0~15m/min(Variable:Option) |
| SAFETY DEVICE | MECHANICAL BRAKE & SLIP CLUTCH | |
| POWER SOURCES | AC 1Ø 220V 50/60Hz | |
| OPERATION METHOD | PUSH BUTTON SWITCH TYPE ON FL | |
| LED DISPLAY | POWER(green) & ALARM(red) | |
| OPERATING TEMPERATURE | -20°C ~ 50°C | |
| International Protection | 54 | |
| LOAD CHAIN | Ø4.0 x P12.0mm x 1fall | |
| PAINT COLOR | 0.4 PB 4.2/5.6 | |
| NET WEIGHT | Max. 19 kg | |

| | | |
|----------------------|--------------|--|
| MODEL | KPT | |
| CAPACITY | 250 kg | |
| I-BEAM WIDTH | 75, 100, 125 | |
| Min. RADIUS of CURVE | 900 mm | |
| TEST LOAD | 312 kg | |
| NET WEIGHT | 7 kg | |

※ Option : 가변형 권상속도
(VARIABLE HOISTING SPEED)

MINI Electric Chain Hoist

BODY Assembly

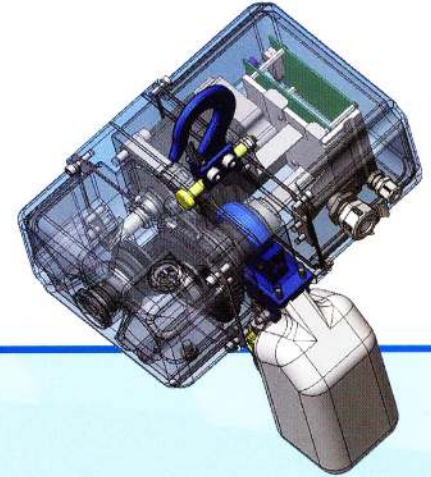

PUSH Button

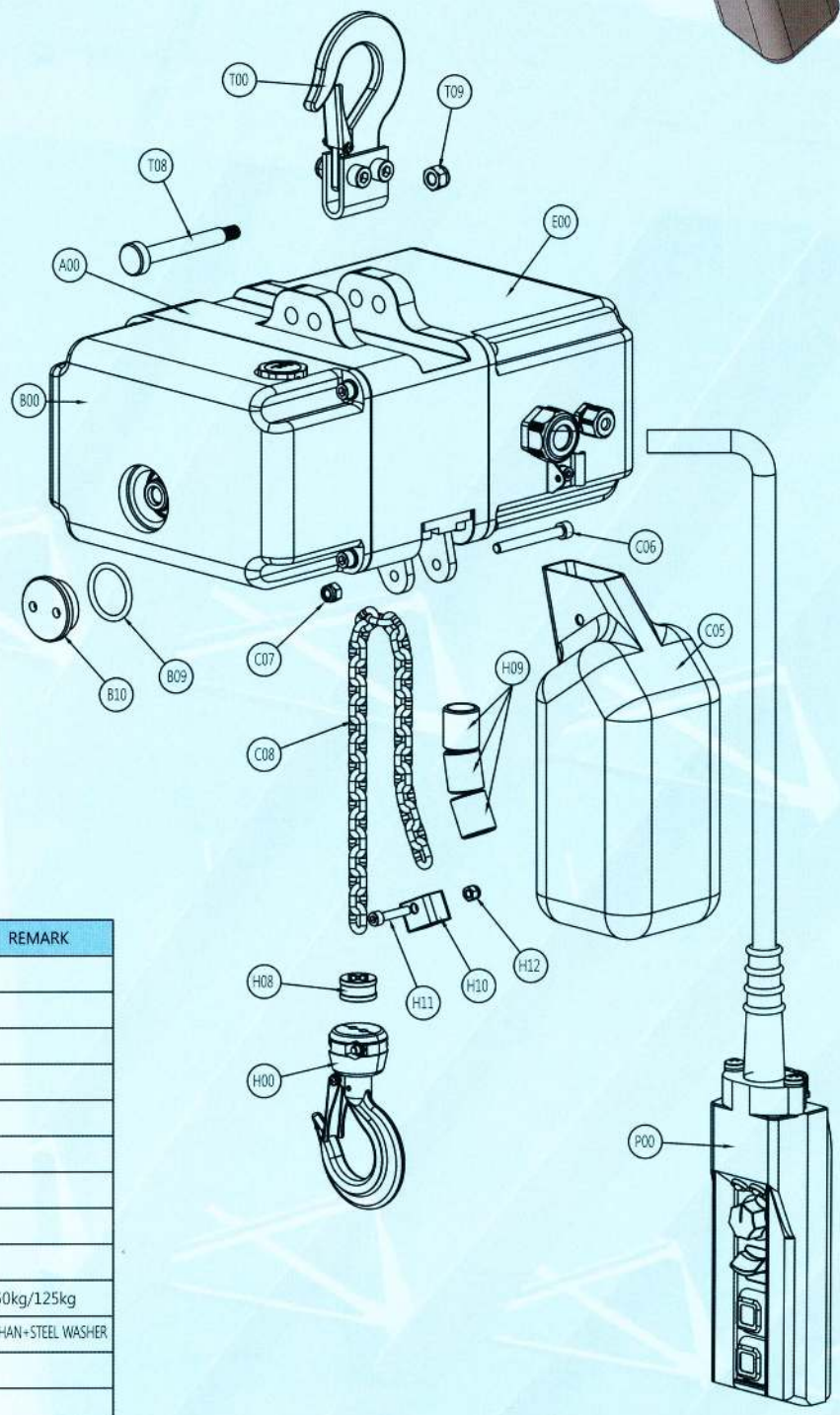
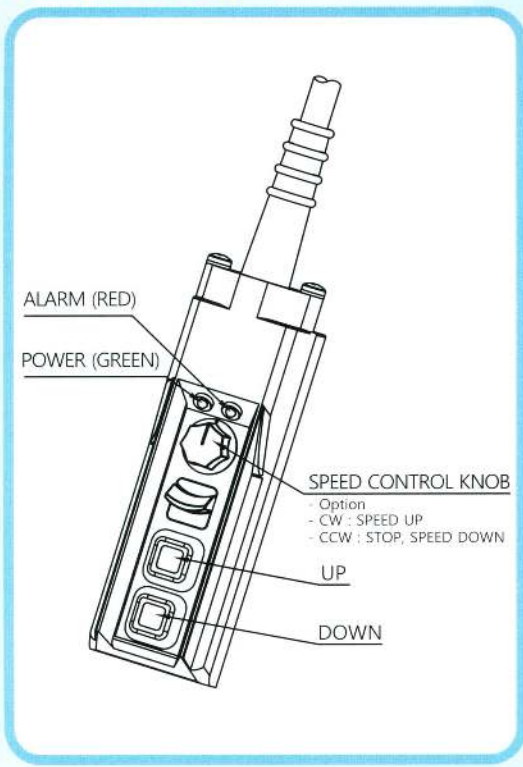

BODY Assembly

| NO | DESCRIPTION | MATERIAL | Q'TY | SIZE | REMARK |
|-----|-----------------------|-----------|------|----------------|----------------------|
| A00 | MAIN BODY Sub Assy | | 1 | MN-250 | |
| B00 | REDUCER CASE Sub Assy | | 1 | MN-250 | |
| B09 | O-RING | PUR. | 1 | P28x3.5 | |
| B10 | TORQUE CONTROL CAP | S45C | 1 | Ø40x13.5 | |
| C05 | CHAIN BUCKET | PLASTIC | 1 | 90x90x162L | |
| C06 | SOCKET HEAD CAP BOLT | PUR. | 1 | M6x55 | |
| C07 | LOCK NUT | PUR. | 1 | M6 | |
| C08 | LOAD CHAIN | AISI15B24 | - | Ø4x15 | |
| E00 | CONTROL PART Sub Assy | | 1 | MN-250 | |
| H00 | BOTTOM HOOK Sub Assy | | 1 | MN-250 | 250kg/125kg |
| H08 | SLIP CUSHION | URETHAN | 1 | Ø22x12.4 | URETHAN+STEEL WASHER |
| H09 | CHAIN STOP HOLDER B | SGP | 3 | Ø21.7x2.6Tx25L | |
| H10 | CHAIN STOP HOLDER A | S45C | 1 | 250kg(125kg) | |
| H11 | SOCKET HEAD CAP BOLT | PUR. | 1 | M5x25 | |
| H12 | LOCK NUT | PUR. | 1 | M5 | |
| T00 | TOP HOOK Sub Assy | | 1 | MN-250 | 250kg/125kg |
| T08 | TOP HOOK PIN | S45C | 1 | Ø20x90L | |
| T09 | LOCK NUT | PUR. | 1 | M8 | |
| P00 | PUSH BUTTON Sub Assy | | 1 | MN-250 | |
| OIL | GEAR OIL | PUR. | 1 | 250cc | MEROPA 220 |

MINI Electric Chain Hoist Example View

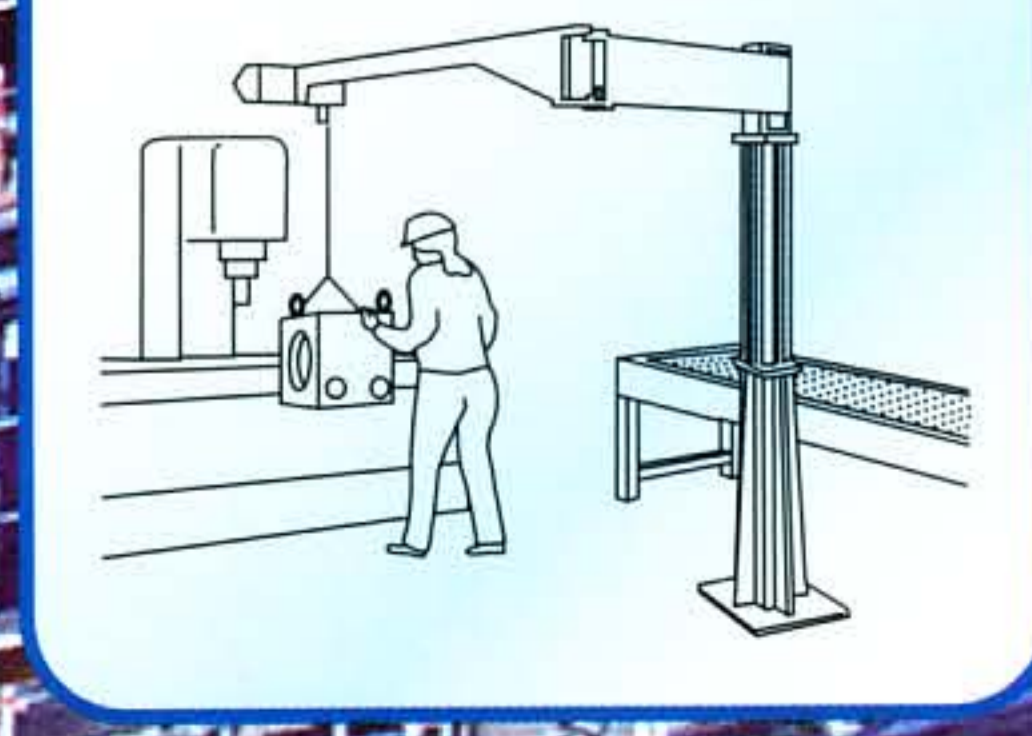
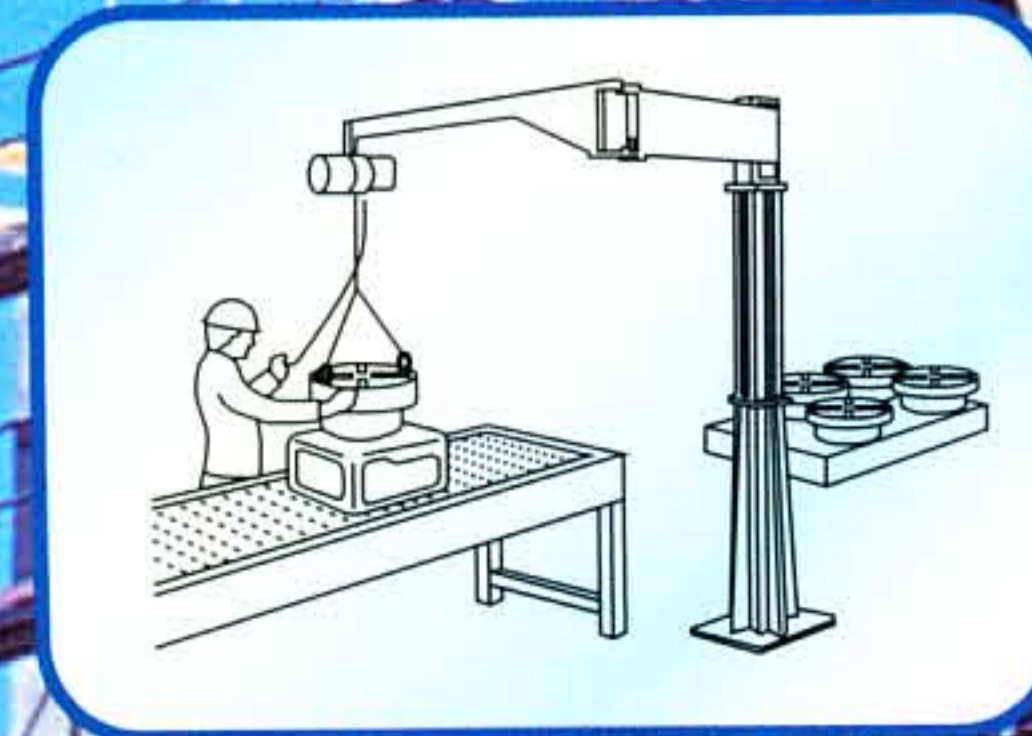
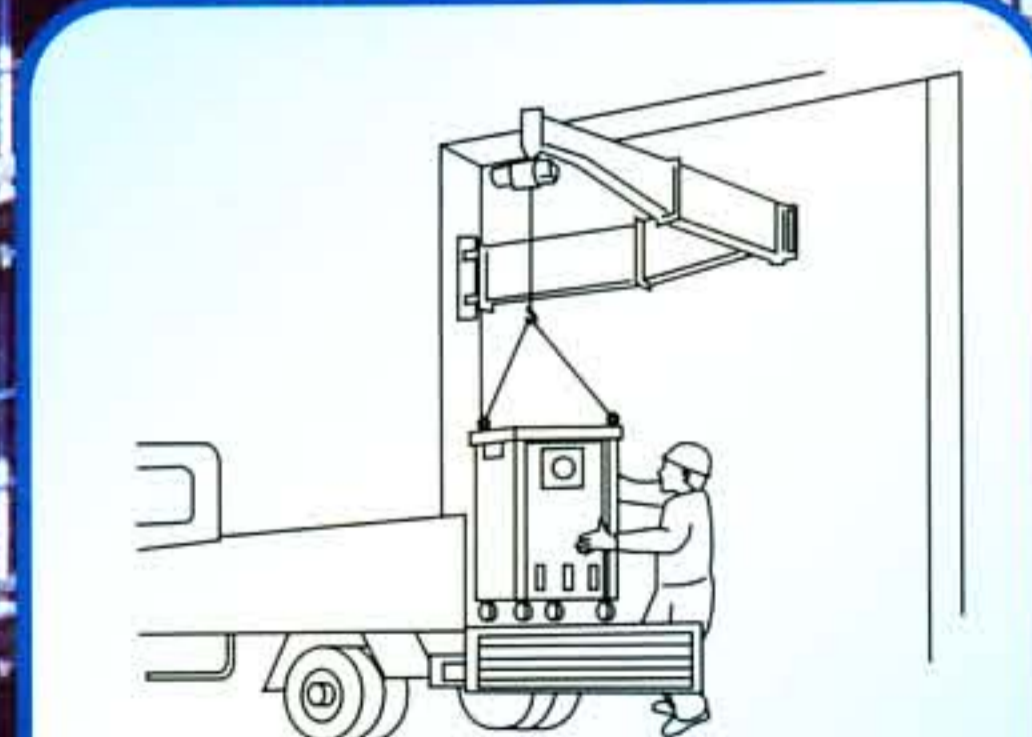
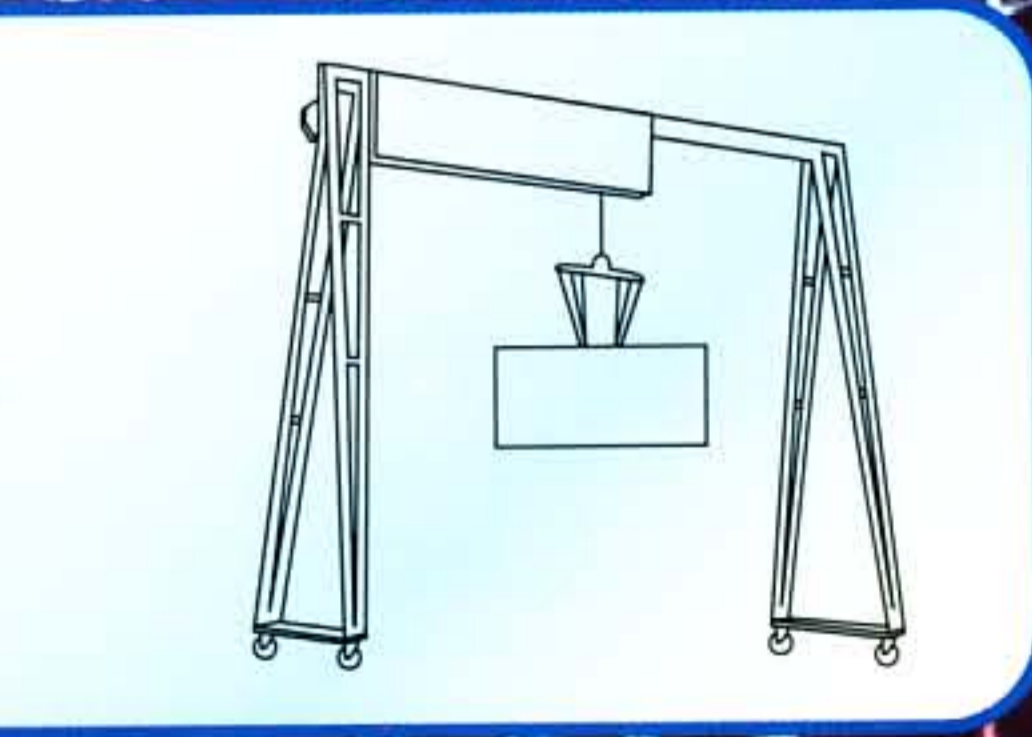
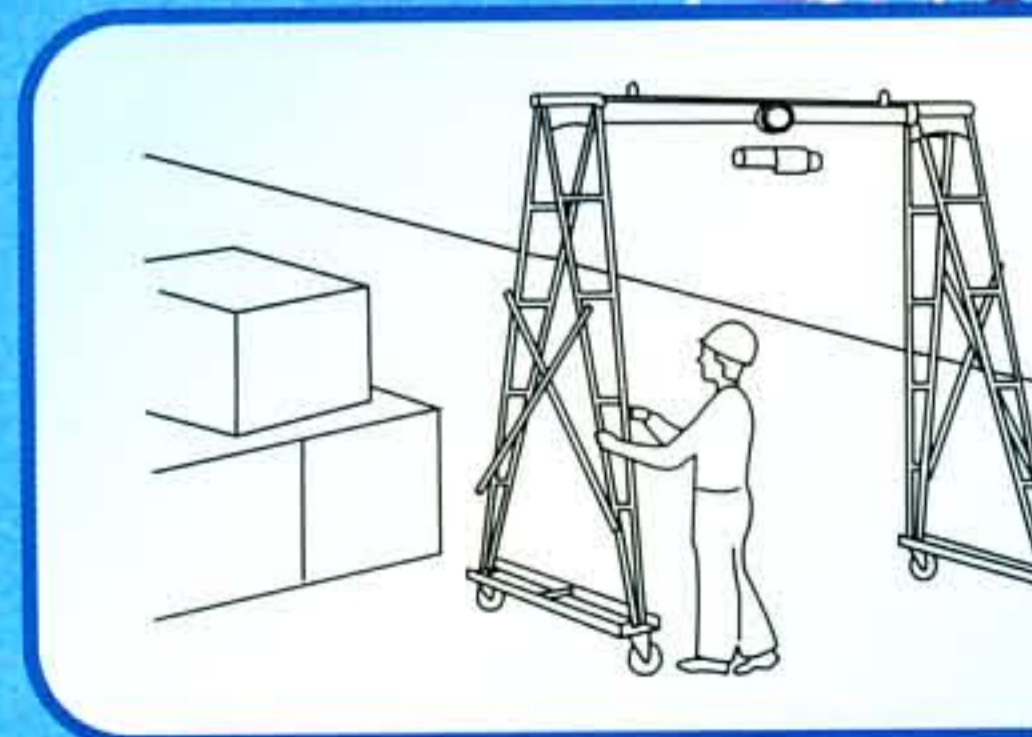
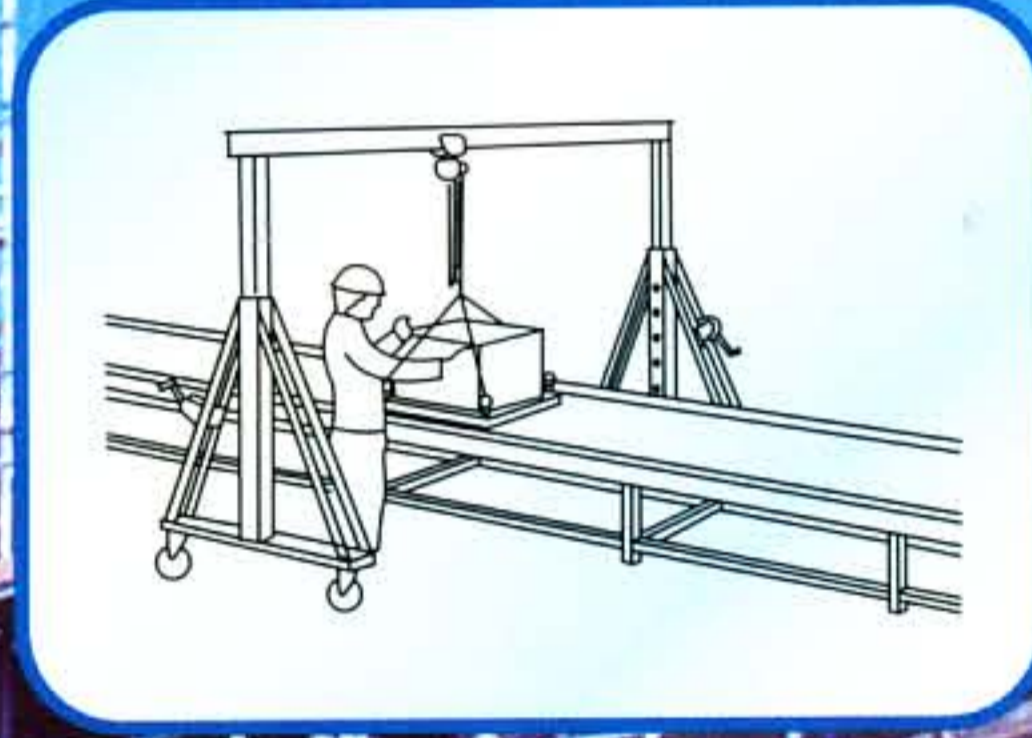
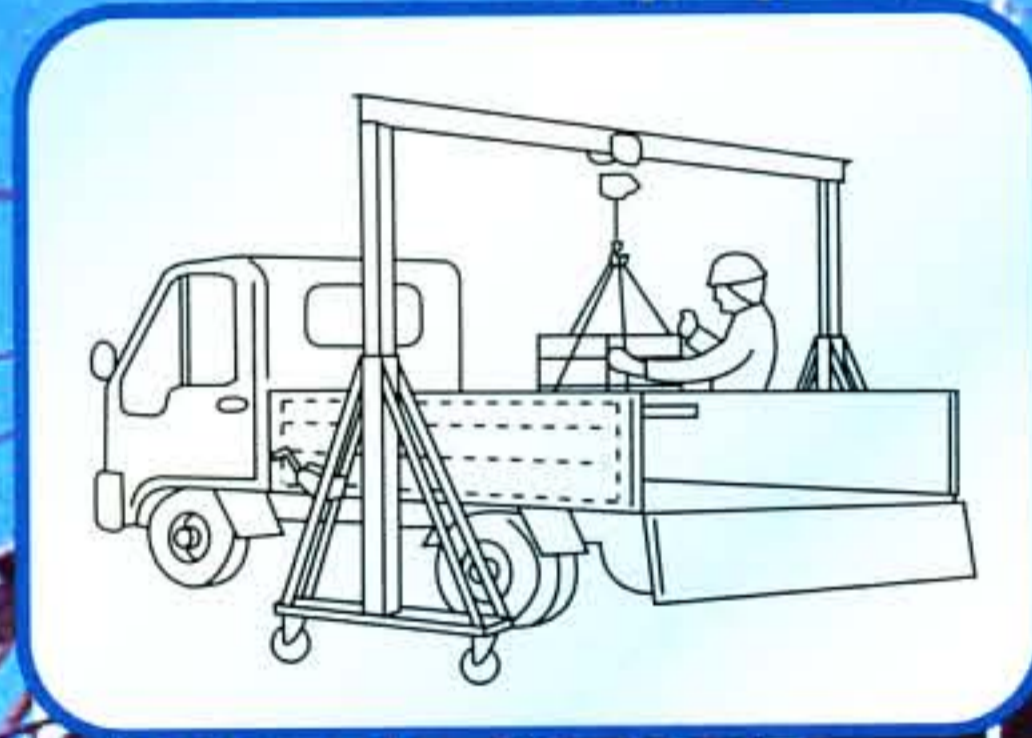
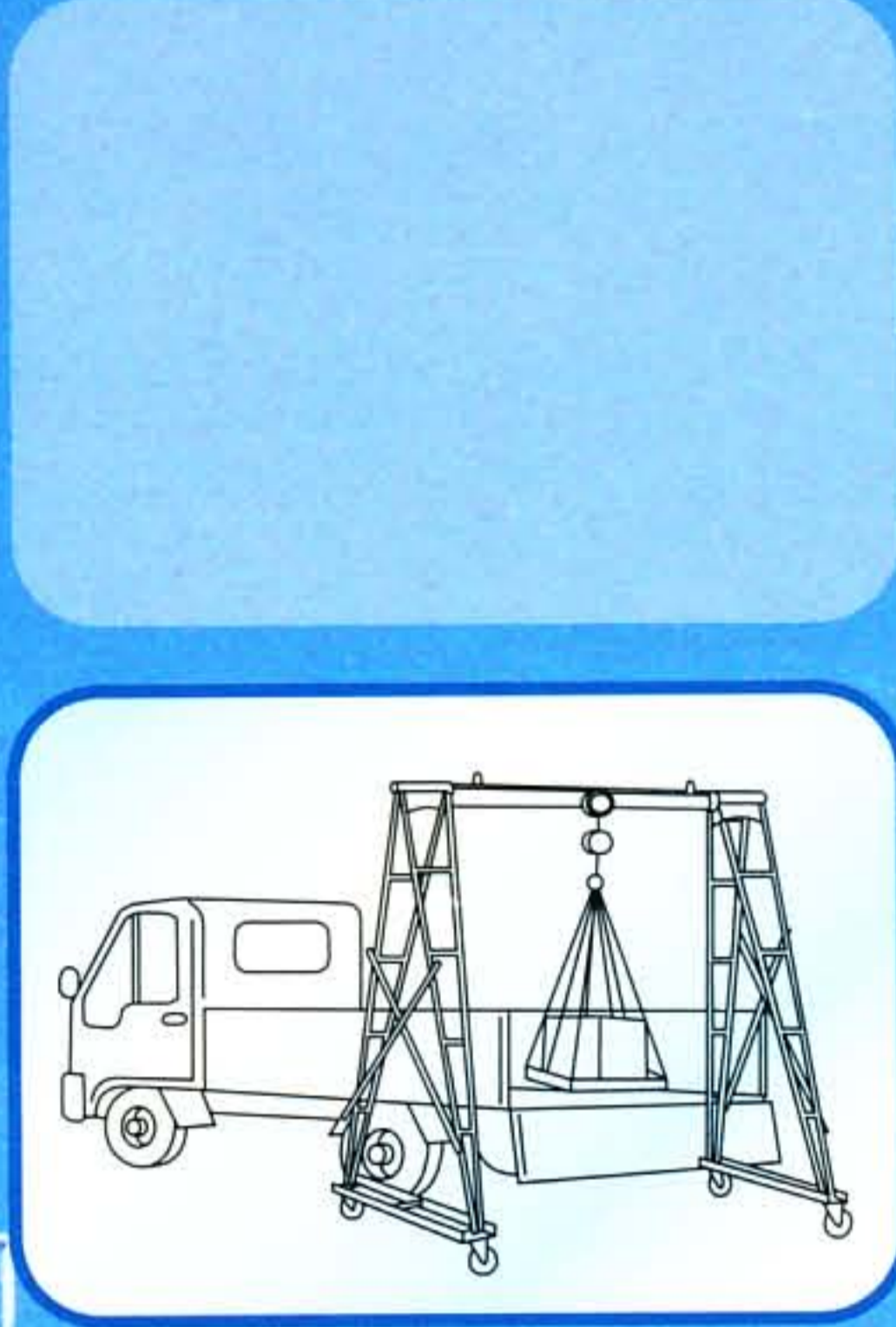
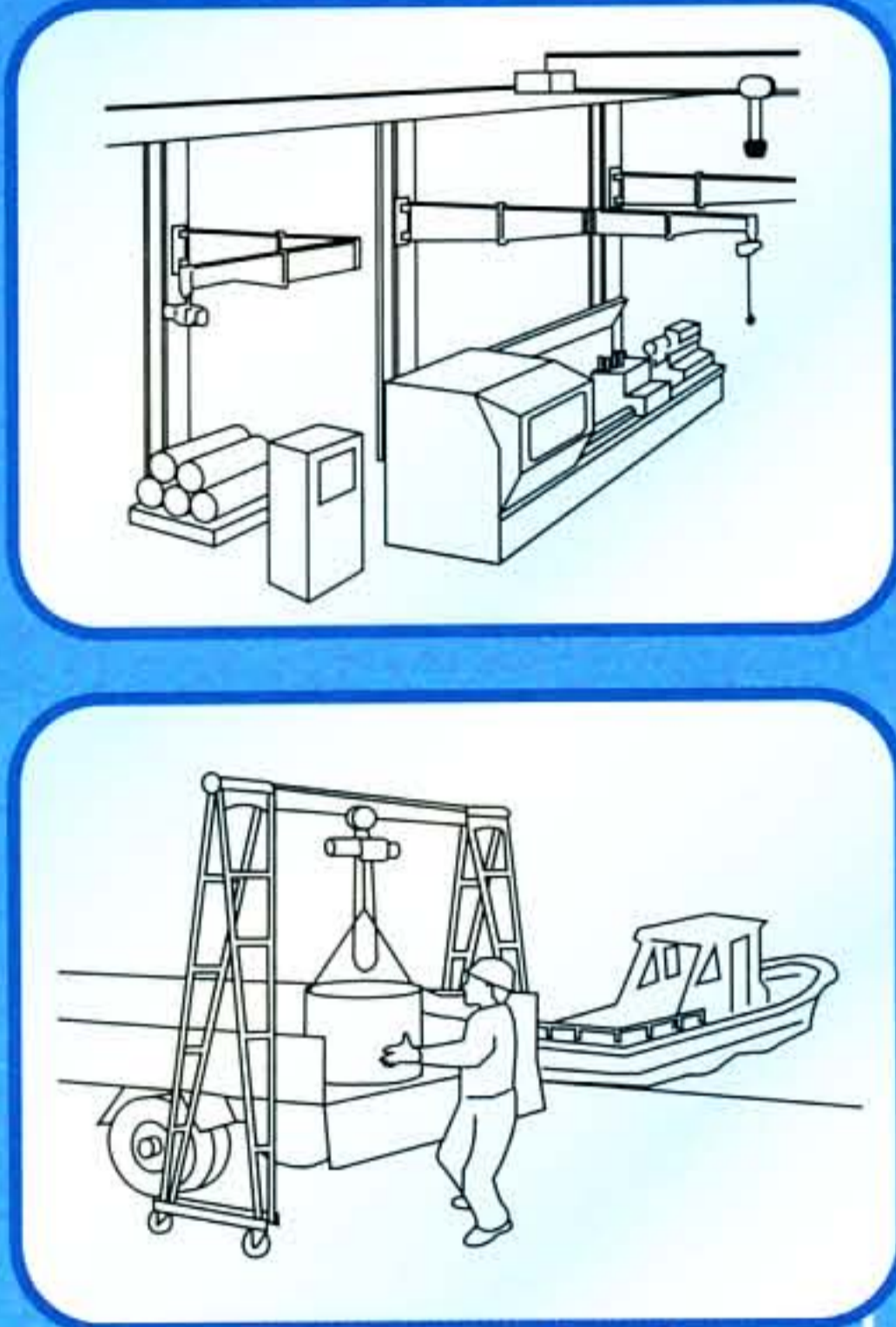
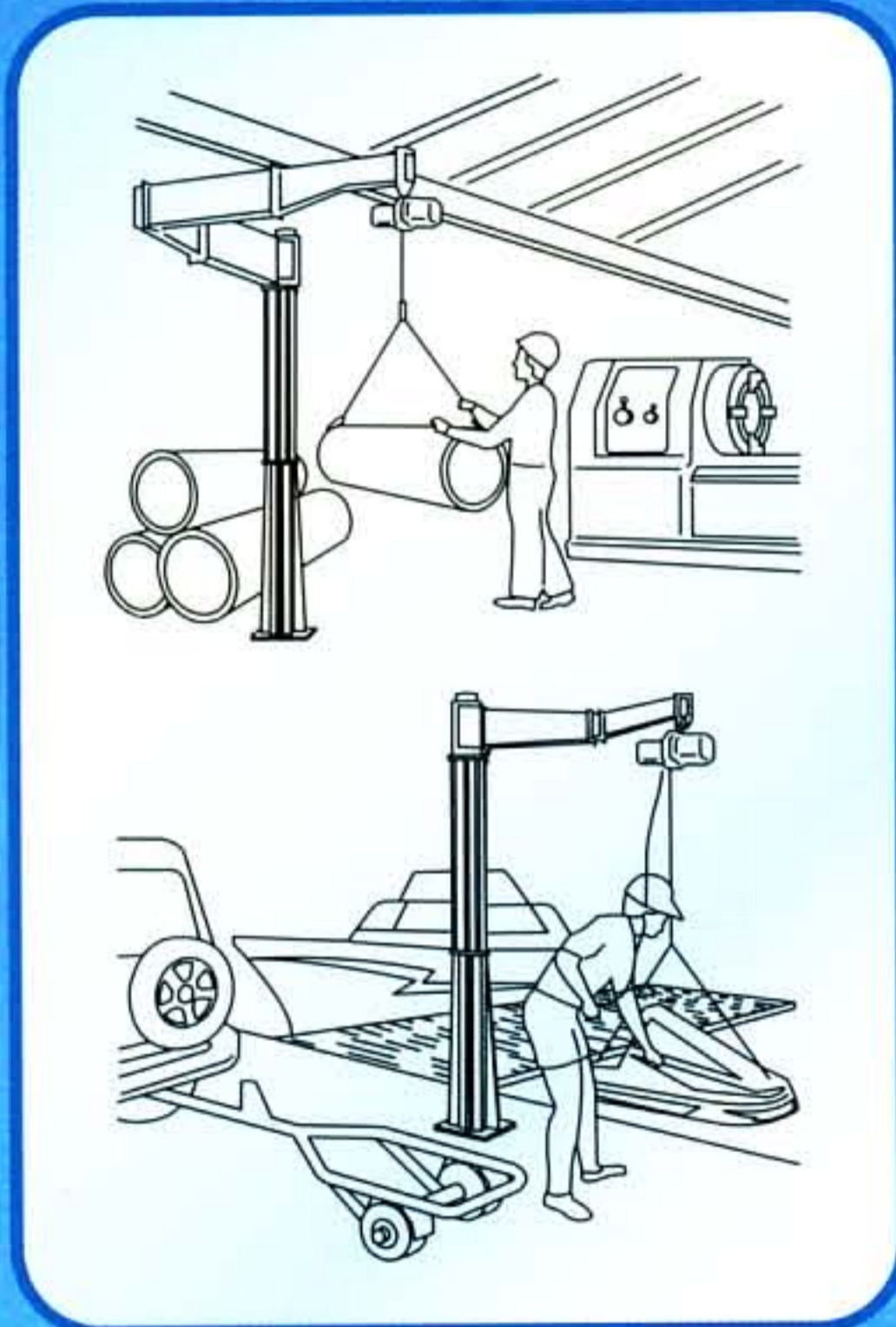
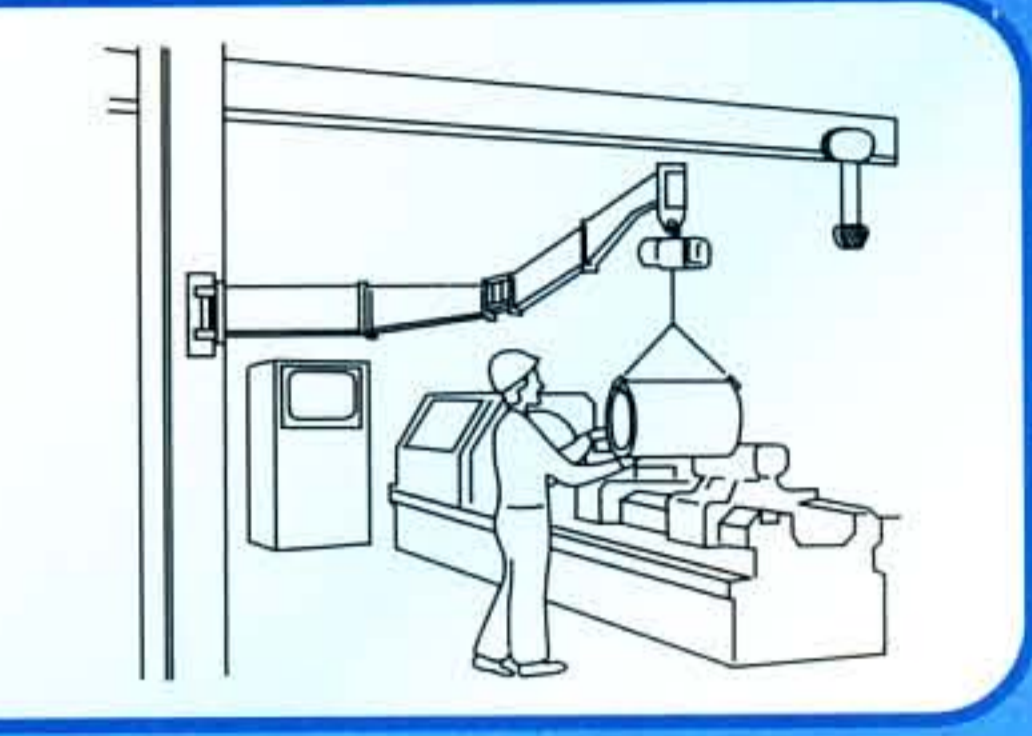
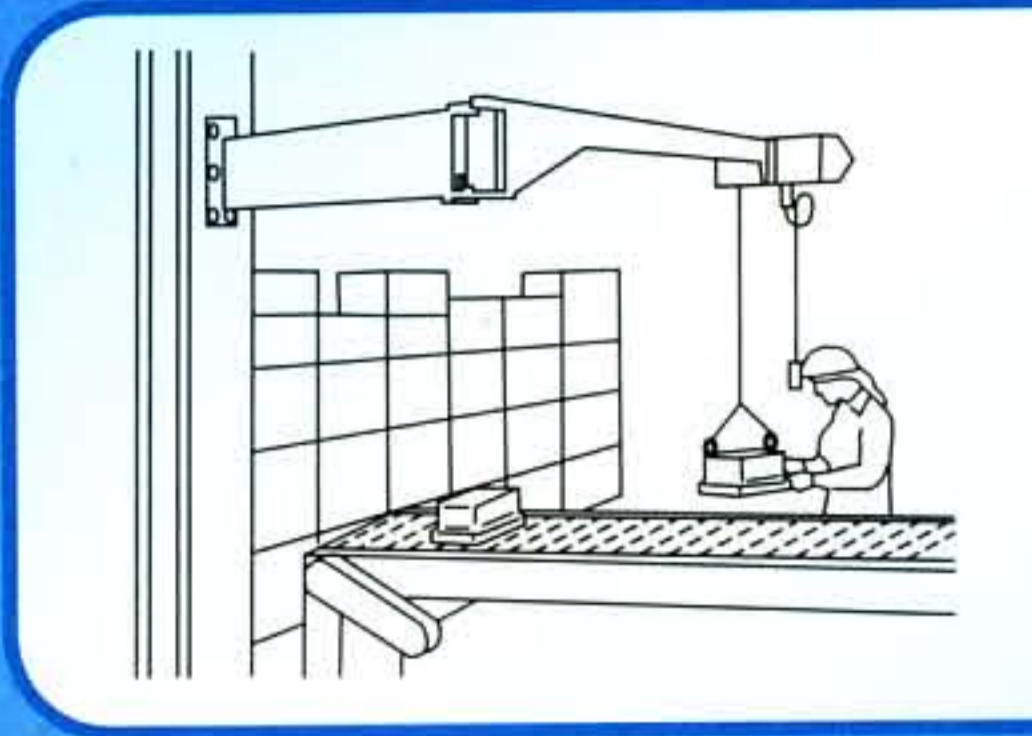
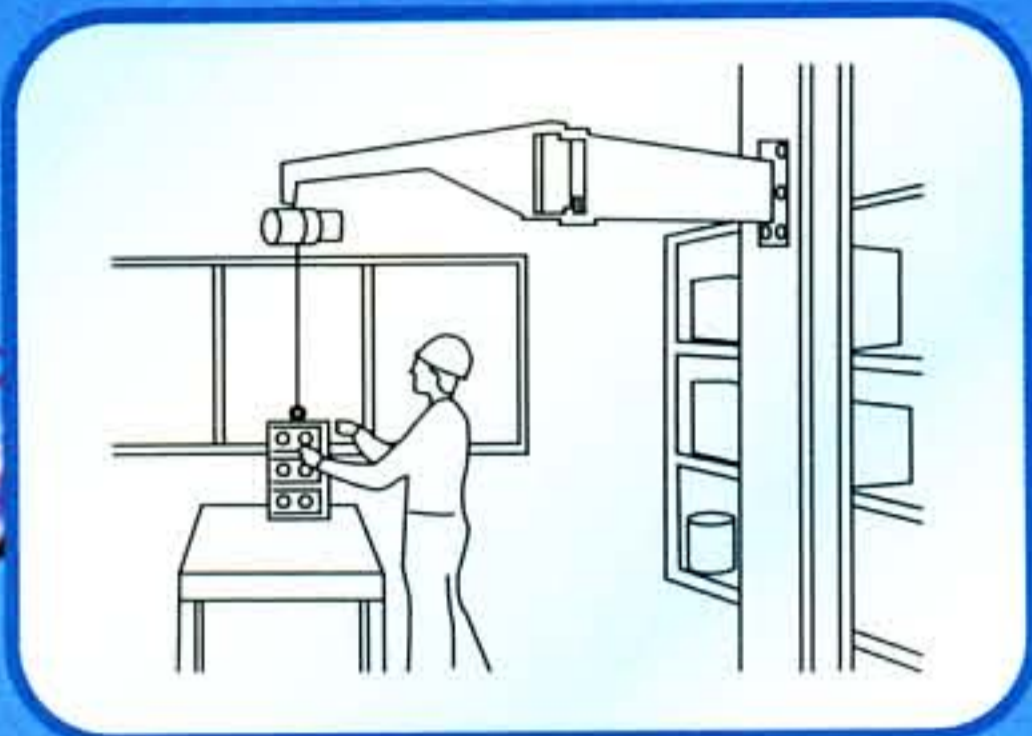

Head Office & Factory

630-2, Sunggok-dong, Danwon-Gu, Ansan-city, Kyunggi-do, KOREA
T. 82-31-491-5311 F. 82-31-492-0473
E-mail : kukdong@kdhoist.com

Overseas DEPT.

T. 82-2-783-4203 F. 82-2-784-6340
E-mail : kukdong@kita.net

A/S Office 080-380-0001

Home-page <http://www.kdhoist.com>

