



综合解说

Comprehensive explanation

注意事项 Matters needing attention

钢基模组系列产品属于机电设备,为维护使用者的安全,在选择机型及实际操作本产品之前,请务必仔细阅读相关型录及下列注意事项并依照指示使用,若未依照本注意事项使用本产品而造成功能异常、损坏或其他事故本公司概不负责。

Steel module series products belong to mechanical and electrical equipment. In order to maintain the safety of users, please read the relevant catalogues and the following precautions carefully before selecting models and actually operating this product. And use it according to the instructions. If the product is not used according to this notice, the company will not be responsible for abnormal function, damage or other accidents.

人生安全 Life safety

- ✱ 本产品适用于工业用途,不可应用在直接与人命或人员相关的保安元件上。
- ✱ 本产品操作运转时人员应维持在机械动作范围外,以免夹伤或发生其他安全事故。
- ✱ 本产品接装电机并通电时,装置心律调节器者应维持在一公尺距离外,以免受到干扰。
- ✱ 本产品勿装置在火源、易燃物、可燃气体附近,以防火灾。

This product is suitable for industrial use, and cannot be applied to security components directly related to human life or personnel. During the operation of this product, personnel should be kept out of the range of mechanical action to avoid pinching or other safety accidents. When this product is connected to the motor and powered on, the pacemaker should be kept at a distance of one meter to avoid interference. This product should not be installed near fire sources, inflammables and combustible gases to prevent fire.

储放与安装 Storage and installation

- ✱ 搬运时应避免坠落或碰撞。
- ✱ 储放本产品时,建议平放并应妥善包装,避免暴露于高温、低温、潮湿的环境。
- ✱ 切勿自行拆解或改装本产品,以免异物进入或产品破坏,造成功能异常或工安事故。
- ✱ 安装时应将本产品锁固,以免因振动松动。
- ✱ 安装联轴器及电机时,须选用适当的元件,并注意对准轴中心线后将螺丝锁固,切勿强行安装。

Avoid falling or collision when handling. When storing this product, it is recommended to lay it flat and properly package it to avoid exposure to high temperature, low temperature and humidity. Do not disassemble or modify this product by yourself, so as to avoid foreign matter entering or product damage, resulting in abnormal function or work safety accidents. When installing, lock the product to avoid loosening due to vibration. When installing the coupling and motor, select appropriate components, and pay attention to lock the screws after aligning with the axis center line, and do not install them forcibly.

操作使用 Operation use

- ✱ 操作时须依照型录记载的额定条件,例如最高转速、负荷等,以免造成功能损坏或工安事故。
- ✱ 应避免粉尘、切屑等异物侵入滚珠循环系统内,造成损坏、寿命减短或功能异常。
- ✱ 操作环境温度应在80°C以下,若需应用在高温场所的产品,请洽谈TPA业务。
- ✱ 环境特殊时,例如强大振动、真空室、无尘室、腐蚀性化学物质、有机溶剂或药剂、极高温或低温、潮湿溅水、油滴油雾、高盐分、重负荷、垂直或悬臂安装等,请先洽谈TPA业务确认本产品适用条件。
- ✱ 垂直安装时,负载有坠落的危险,建议加装适当的刹车,并于使用前确认刹车功能正常。

Operation shall be in accordance with rated conditions recorded in catalogue, such as maximum speed and load, so as to avoid functional damage or work safety accidents. Avoid dust, chips and other foreign bodies invading the ball circulation system, causing damage, shortened service life or abnormal function. The operating temperature should be below 80°C. If you need to apply products in high temperature places, please discuss TPA business. Under special circumstances, such as strong vibration, vacuum chamber, clean room, corrosive chemicals, organic solvents or chemicals, extremely high or low temperature, wet splashing water, oil droplets and fog, high salinity, heavy load, vertical or cantilever installation, etc., please negotiate TPA business first to confirm the applicable conditions of this product. During vertical installation, the load is in danger of falling. It is recommended to install appropriate brakes, and make sure that the brake function is normal before use.

维护 maintenance

- ✱ 初次使用前应先将润滑油补满,请注意油品种类,不同的润滑油不可混用。
- ✱ 正常使用状况下建议每行100km应检查运转状况一次‘清除积污’并补充润滑油导轨及螺杆均应保持润滑。

Fill up the lubricating oil before using for the first time. Please pay attention to the types of oil products. Different lubricating oils cannot be mixed. Under normal operating conditions, it is recommended to check the operating condition once every 100km to 'clean up accumulated dirt' and replenish lubricating oil. Guide rails and screws should be kept lubricated.

产品特色 Product features

- ✱ 产品多样化可搭配需要选用。
- ✱ 驱动方式:滚珠螺杆。
- ✱ 电机出力:可自行选配伺服电机或步进电机。
- ✱ 电机连接:直接、上接、下接、左接、右接,依使用空间而定。
- ✱ 有效行程:50~1600mm(依螺杆转速限制)。
- ✱ 组装与维护容易。
- ✱ 可依顾客需要做客制化、单件或组合件的特殊设计制造。
- ✱ 单轴可组合成多轴使用。

Diversified products can be matched and needed to be selected. Driving mode: ball screw. Motor output: servo motor or stepping motor can be selected. Motor connection: direct, upper connection, lower connection, left connection and right connection, depending on the use space. Effective travel: 50 ~ 1600 mm (limited by screw speed). Easy to assemble and maintain. According to customers' needs, we can make customized, single-piece or combined special design and manufacture. Single axis can be combined into multiple axes.

电机法兰座、电机与联轴器安装注意事项 Precautions for installation of motor flange seat, motor and coupling

- ✱ 螺杆肩部与电机轴两轴组装时,需注意以下三种基本偏差,说明图示如下:

When assembling the screw and the motor shaft, the following three basic deviations should be paid attention to. The illustration is as follows:

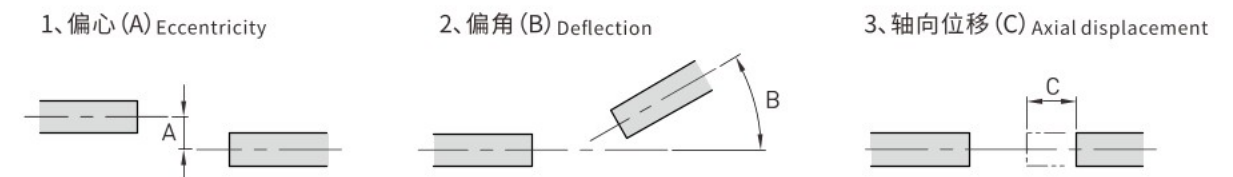

- ✱ 两轴中心线简易校准确认方式,可将位于螺杆肩部与电机轴间的联轴器处于松动状态下,转动联轴器,确认联轴器是否能够沿轴向旋转方向轻轻移动,以确认两轴心的同心度,说明图示如右:

A simple calibration and confirmation method of two shaft centerlines can loosen the coupling between the shoulder of the screw and the motor shaft. Next, turn the coupling to confirm whether the coupling can move gently along the axial rotation direction to confirm that the two axes are the same. Here, the illustration is as shown on the right:

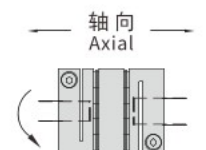

- ✱ 螺杆肩部(A)与电机法兰座定位孔(B)的同心度,请制作轴孔同心治具协助安装,说明图示如下:

For the concentricity of the screw shoulder (A) and the positioning hole (B) of the motor flange seat, please make a concentric jig for the shaft hole to assist the installation. The illustration is as follows:

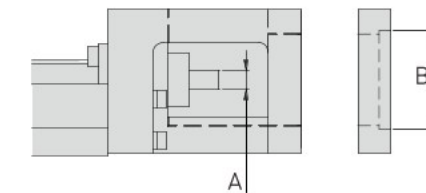

安装注意事项: Installation precautions:

- 电机法兰座安装时,请注意电机法兰座定位孔与螺杆肩部的偏差需在联轴器相关容许偏差值内。
 - 螺杆肩部与电机轴两轴的偏差过大时,仍强行装上联轴器,会造成联轴器或螺杆肩部断裂的情况产生,所以请确认两轴的偏差是在联轴器可以容许偏差值内。
 - 选用联轴器时,建议选择可吸收偏心、偏角与轴向位移的挠性联轴器。
1. When installing the motor flange seat, please note that the deviation between the positioning hole of the motor flange seat and the shoulder of the screw should be within the allowable deviation of the coupling.
2. When the deviation between the screw shoulder and the motor shaft is too large, the coupling is still forcibly installed, which will cause the fracture of the coupling or the screw shoulder, so please make sure that the deviation between the two shafts is connected. The shaft can be within the allowable deviation.
3. When selecting coupling, it is recommended to choose flexible coupling which can absorb eccentricity, deflection angle and axial displacement.



选型步骤 Selection step

单轴机器人产品的选用,依不同使用条件及限制,可参考下列选用流程。
The selection of single-axis robot products can refer to the following selection process according to different use conditions and restrictions.

<p>1、使用条件 1. Conditions of use</p> <ul style="list-style-type: none"> * 有效行程 Effective itinerary. * 空间位置限制(宽度、高度、长度) Spatial restrictions (width, height, length). * 安装方式(水平、垂直、侧挂) Installation method (horizontal, vertical, side hanging). * 负载重心位置 Load center of gravity position. * 运转条件(导程、速度、加减速、工作周期) Operating conditions (lead, speed, acceleration and deceleration, working cycle). * 使用环境(高温、振动、油、水、腐蚀) Service environment (high temperature, vibration, oil, water, corrosion). 	<p>5、电机负载计算 5. Calculation of motor load</p> <ul style="list-style-type: none"> * 最高速度 Top speed. * 电机解析度 Motor resolution. * 电机扭矩计算 Calculation of motor torque.
<p>2、要求精度 2. Accuracy is required.</p> <ul style="list-style-type: none"> * 位置精度 Position accuracy. * 重现精度 Reproduction accuracy. * 行走平行度 Walking parallelism. 	<p>6、运转分析 6. Operation analysis</p> <ul style="list-style-type: none"> * 加速度 Acceleration. * 实际运转模式 Actual operation mode.
<p>3、应用形式 3. Application form</p> <ul style="list-style-type: none"> * 单轴 Uniaxial. * 两轴 Two axes. * 多轴 Multi-axis. * 特殊组合 Special combination. 	<p>7、其他配件 7. Other accessories</p> <ul style="list-style-type: none"> * 相关配件选用 (极限开关、转接板、伸缩护套、电缆保护管) Selection of related accessories (limit switch, adapter plate, telescopic sheath, cable protection tube)
<p>4、电机选用 4. Selection of motor</p> <ul style="list-style-type: none"> * AC伺服电机 AC servo motor. * 步进电机 Stepping motor. * 有无刹车(内附、外挂) With or without brakes (internal and external). 	<p>8、最终确认 8. Final confirmation</p> <ul style="list-style-type: none"> * 使用条件再确认 Re-confirm the use conditions. * 价格、交期 Price and delivery date. * 追加加工 Additional processing. * 特殊要求 Special requirements.

精度 accuracy

精度包含准确度与精密度,如下说明: Accuracy includes accuracy and precision, as follows:

1、定位精度(准确度) Positioning accuracy (accuracy)

模组由基准点沿一方向移动,最终实际到达的距离与原设定到达的距离的最大差异值(绝对值)称之为定位精度。

The module moves in one direction from the reference point, and the maximum difference (absolute value) between the final actual distance and the original set distance is called positioning accuracy.

2、往返位置重现性(精密度) Reproducibility (precision) of round-trip position

指定位置重现性,表示钢基模组往返移动过程中,在某一设定位置测得的位置差异值,以全行程中的最大值称之为往返位置重现性。

Specified bit reproducibility, which means the position difference value measured at a certain set position during the reciprocating movement of the steel-based module, and the maximum value in the whole journey is called the reciprocating position reproducibility.

3、行走平行度 Walking parallelism

(1) 指钢基模组的滑台平面与模组安装平面之间的平行度。量表架于滑台平面中央,指针置于安装平面上,取全行程量测的最大差异。

(2) 指钢基模组的滑台与模组安装基准面之间的平行度。量表架于滑台侧边安装基准面上,取全行程量测的最大差异值。

(1) refers to the parallelism between the sliding table plane of the steel-based module and the module installation plane. The gauge is placed in the center of the plane of the sliding table, and the pointer is placed on the installation plane, so as to take the maximum difference of the whole stroke measurement.

(2) It refers to the parallelism between the sliding table of the steel-based module and the module installation datum plane. The gauge is mounted on the mounting datum at the side of the sliding block, and the maximum difference value of the whole stroke measurement is taken.

速度 Speed

1、最大线速度 Maximum linear velocity

钢基模组最大线速度(V)系由滚珠螺杆最高转速(S)乘以导程(L)计算而得。

The maximum linear velocity (V) of the steel base module is calculated by multiplying the maximum rotational speed (S) of the ball screw by the lead (L).

$$V(\text{mm/sec}) = S(\text{rpm}) \div 60 \times L(\text{mm})$$

2、最高转速 Maximum speed

表示滚珠螺杆的最大容许转速由其临界转速而定。螺杆转速超过临界转速时将可能发生共振。

临界转速和螺杆长度有关,因此,滚珠螺杆的临界转速也间接决定的有效行程和总长度。

滚珠螺杆的最大容许转速计算方式如下:

Indicates that the maximum allowable rotational speed of the ball screw depends on its critical rotational speed. Resonance may occur when the screw speed exceeds the critical speed.

The critical speed is related to the screw length, so the critical speed of the ball screw indirectly determines the effective stroke and total length.

The maximum allowable speed of ball screw is calculated as follows:

$$N_p = 0.8 \times 2.71 \times 10^8 \times \frac{M_f d_r}{L_t^2}$$

N_p = 最大容许转速 [rpm]

M_f = 组装型式系数, $M_f = 0.689$

d_r = 螺杆根径 [mm]

L_t = 轴承间的螺杆跨距 [mm]

N_p = Maximum allowable speed [rpm]

M_f = assembly type coefficient, $M_f = 0.689$

d_r = screw root diameter [mm]

L_t = screw span between bearings [mm]

3、加减速速度 Acceleration and subtraction speed

所谓速度系指滑台设定的运转工作速度,滑台须自停止状态开始加速,达工作速度后维持该速度往目的地移动,抵达前开始减速,终至停止。

加减速速度由使用者依实际需要而定,钢基模组设计时,加速度的设定:导程5以下以0.15G计算,其他导程均以0.3G计算。

1G=9.8m/s²;则0.15G=1470mm/s²;0.3G=2940mm/s²。钢基模组最大可搬质量须依加速度而定。

*注意:加减速速度将使搬运的质量产生惯性负荷,加减速速度愈大,可搬质量愈小。过大的加减速速度会产生大的冲击力,应避免之。

The so-called speed refers to the running working speed set by the sliding table. The sliding table must start to accelerate from the stop state, maintain the speed to move to the destination after reaching the working speed, and start to slow down before arrival, and finally arrive. Stop.

The acceleration and deceleration speed is determined by the user according to the actual use needs. When designing the steel-based module, the acceleration is set as follows: 0.15G for lead 5 or less, and 0.3G for other leads.

1G=9.8m/s²; 0.15g=1470mm/s²; 0.3G=2940mm/s². The maximum movable mass of the steel base module depends on the acceleration.

* Note: The acceleration and deceleration will cause inertia load to the handling quality. The greater the acceleration and deceleration, the smaller the movable quality. Excessive acceleration and deceleration will produce great impact and should be avoided.

4、工作周期 Work cycle

工作周期由客户依实际需要决定。常用工作周期如下图所示,包括加速时间Ta、等速时间Tc、减速时间Td、停留时间Tf。

The work cycle is determined by the customer according to the actual needs. Common working cycles are shown in the figure below, including acceleration time Ta, constant speed time Tc, deceleration time Td and residence time Tf.

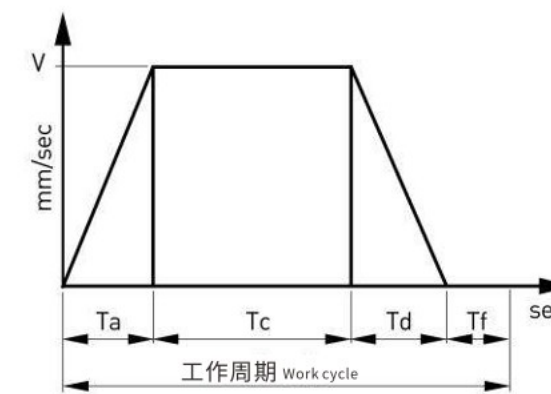

加速度=V/Ta

减速度=V/Td

工作周期(sec)=Ta + Tc + Td + Tf

工作时间=工作周期×次数

运转率=工作时间/(工作时间+停机时间)

运转率需配合电机负荷而定,通常不宜长时间连续不停的工作,

建议以0.5为准。

Acceleration = v/Ta

Deceleration = v/Td

Work cycle (sec) = Ta+Tc+Td+Tf

Working time = working period × times

Operating rate = working time/(working time+downtime)

The operating rate depends on the motor load, and it is usually not suitable to work continuously for a long time. Recommendation 0.5 shall prevail.



电机负载计算 Motor load calculation

1、确认负载机构的运动条件要求,包括加减速速度,运动速度,机构的重量,机构的运动方式。
Confirm the movement conditions of the loading mechanism, including acceleration and deceleration, movement speed, weight of the mechanism and movement mode of the mechanism.

2、负载之惯量计算 Calculation of inertia of load

直线运动负载惯量计算方式: Calculation method of linear load inertia:

$$J_L = W \times \left(\frac{V}{2 \times \pi \times N \times 10} \right)^2 = W \times \left(\frac{\Delta S}{20 \times \pi} \right)^2$$

J_L : 负载惯量,计算至电机输出轴[kg·cm²]
 V : 负载直线运动速度[mm/min]
 ΔS : 电机转一圈,负载的移动量[mm]
 W : 负载重量[kg]
 N : 电机转速[r/min]

J_L : load inertia, calculated to the output shaft of the motor [kg cm²]
 V : linear movement speed of load [mm/min]
 ΔS : the movement of the load [mm] when the motor rotates once.
 W : load weight [kg]
 N : Motor speed [r/min]

3、由负载惯量与电机惯量的比例原则,选出适当的电机规格。

According to the proportional principle of load inertia and motor inertia, the appropriate motor specification is selected.

4、将选定的电机惯量合并负载惯量,计算出加速转矩及减速转矩。

Combine the selected motor inertia with the load inertia to calculate the acceleration torque and deceleration torque.

加速转矩: Acceleration torque:

$$T_a = \frac{(J_L + J_M) \times N}{9.55 \times 10^4 \times T_{psa}}$$

J_L : 负载惯量,计算至电机输出轴[kg·cm²]
 J_M : 电机惯量[kg·cm²]
 N : 电机转速[r/min]
 T_{psa} : 加速时间[s]
 T_{psd} : 减速时间[s]

减速转矩: Deceleration torque:

$$T_d = \frac{(J_L + J_M) \times N}{9.55 \times 10^4 \times T_{psd}}$$

J_L : 负载惯量,计算至电机输出轴[kg·cm²]
 J_M : 电机惯量[kg·cm²]
 N : 电机转速[r/min]
 T_{psa} : 加速时间[s]
 T_{psd} : 减速时间[s]

5、依据负载重量,安装方式,摩擦系数,电机效率,计算出等速运动时的负载转矩。

According to the load weight, installation method, friction coefficient and motor efficiency, the load torque at constant speed is calculated.

$$T_L = \frac{F \times V}{2 \times 10^3 \times \pi \times \eta \times N} = \frac{F \times \Delta S}{2 \times 10^3 \times \pi \times \eta}$$

J_L : 直线运动时的轴向力 $F = F_c + \mu \times (W_x g + F_o)$
 T_L : 负载转矩[N·m]
 F_c : 轴方向的外加作用力[N]
 F_o : 负载对SR模组的外加正压力[N]
 W : 负载重量(含滑台)[kg]
 μ : 摩擦系数
 η : 机械效率
 V : 负载直线运动速度[mm/min]
 N : 电机转速[r/min]
 g : 重力加速度(9.8m/s²)
 ΔS : 电机转一圈,负载的移动量[mm]

J_L : Axial force in linear motion
 T_L : Torque [N·m]
 F_c : Axial applied force [N]
 F_o : External positive pressure on the loaded SR module [N]
 W : Weight (including sliding table) [kg]
 μ : coefficient of friction
 η : Mechanical efficiency
 V : Linear motion speed of load [mm/min]
 N : Motor speed [r/min]
 g : Gravity acceleration (9.8m/s²)
 ΔS : The movement of the load [mm] after one revolution of the motor.

6、选定电机的最大输出转矩,须大于加速转矩和负载转矩相加的和;如果不符合条件,必须选用其他型号,再计算验证至符合要求为止。

The maximum output torque of the selected motor must be greater than the sum of acceleration torque and load torque; If it does not meet the requirements, other models must be selected and then calculated. Until it meets the requirements.

7、依据负载转矩、加速转矩、减速转矩及保持转矩,求出连续实效转矩。

According to the load torque, acceleration torque, deceleration torque and holding torque, calculate the continuous effective torque.

$$T_{RMS} = \sqrt{\frac{T_a^2 \times T_{psa} + T_L^2 \times t_c + T_d^2 \times T_{psd} + T_{LH}^2 \times t_h}{T_f}}$$

T_{psa} : 加速时间[s] T_{psa} : Acceleration time [s] t_c : 等速时间[s] t_c : Isokinetic time [s]
 T_{psd} : 减速时间[s] T_{psd} : Deceleration time [s] t_h : 停止时间[s] t_h : Stop time [s]
 T_f : 周期时间 T_f : Periodic time T_a : 加速转矩 T_a : Acceleration torque
 T_L : 负载转矩[N·m] T_L : Torque [N·m] T_d : 减速转矩 T_d : Deceleration torque
 T_{LH} : 保持转矩(水平运动时, $T_{LH}=0$) T_{LH} : Holding torque (when moving horizontally $T_{LH}=0$)

8、选定电机的额定输出转矩必须大于连续实效转矩;如果不符合条件,必须选用其他型号,再计算验证至符合要求为止。

The rated output torque of the selected motor must be greater than the continuous effective torque; If it does not meet the requirements, other models must be selected, and then calculated and verified to meet the requirements. Until now.

安装 Installation

滚珠螺杆型式若确定用途为垂直方向(z轴)请注意,垂直安装属于特殊使用状态,承载负荷请在表列最大可搬重量(直立)范围内使用,除此之外,时规皮带带式禁止垂直方向使用。

*注意:为防止负载滑落,垂直安装时,采用电机宜含刹车。

If the ball screw type is determined to be used in the vertical direction (Z axis), please note that the vertical installation is a special use state, and the bearing load should be used within the maximum movable weight (vertical) listed in the table, except that Besides, it is forbidden to use the timing belt type in the vertical direction.

* Note: In order to prevent the load from slipping, when installing vertically, the motor should include brakes.

保养 Maintenance

钢基模组需要维修保养的部分包括滚珠螺杆、U型导轨及相关配件。每三个月或每行走100公里的距离后,必须对滚珠螺杆和直线导轨补充润滑剂,并请检查有无任何污垢或碎屑在系统内,如果油脂变得肮脏时,请更换油脂。如有任何保养方面的特殊问题请与TPA联络。

Parts of the steel base module that need maintenance include ball screws, U-shaped guide rails and related accessories. Every three months or every 100 kilometers, lubricant must be added to the ball screw and linear guide rail, and please check whether there is any dirt or debris in the system. If the grease becomes dirty, please replace the grease. Please contact TPA if you have any special maintenance problems.

产品应用 Product application

钢基模组系列产品用途广泛,一般自动化设备均可应用,举例如下:

自动锡焊机、锁螺丝机、料架零件盒取放、小型堆栈、黏胶涂布机、零附件取放搬运、CCD镜头移动、自动喷漆机、自动上下料装置、切割机、电子元件生产设备、小型装配线、小型压台、点焊机、表面复膜制程、自动贴标签机、液料灌注分装、零附件检验设备、生产线工件整理、材料充填装置、包装机、刻印机、输送带移位、工件清洁装置等等。

Steel base module series products are widely used and can be used in general automation equipment, for example: Automatic tin welding machine, screw-locking machine, pick-and-place of rack parts box, small stack, glue coating device, pick-and-place and transport of parts, CCD lens movement, automatic paint sprayer, automatic loading and unloading device, cutting machine, Electronic component production equipment, small assembly line, small pressing table, spot welding machine, surface laminating process, automatic labeling machine pasting, liquid material pouring and packaging, spare parts inspection equipment, work piece finishing in production line, and material processing. Material filling device, packaging machine, marking machine, conveyor belt shift, workpiece cleaning device, etc.



寿命的计算 Calculation of life span

1、寿命。Life.

当线性滑轨承受负荷并作运动时，珠道表面与钢珠因不断地受到循环应力的作用，一旦到达滚动疲劳的临界值，接触面就会开始产生疲劳破损，并在部份表面发生鱼鳞状薄片的剥落现象，此种现象叫做表面剥离。寿命的定义即为珠道表面及钢珠因材料疲劳而产生表面剥离时为止的总运行距离。

When the linear guide rail bears the load and moves, the bead surface and the steel ball are constantly subjected to cyclic stress, and once they reach the critical value of rolling fatigue, they are connected. The contact surface will start to be fatigued and damaged, and the peeling phenomenon of fish scales will occur on some surfaces, which is called surface peeling. Life is defined as The total running distance between the bead surface and the surface peeling of steel balls due to material fatigue.

2、额定寿命。Rating life.

单轴机器人的寿命，具有很大的分散性，即使同一批制造的产品，在相同的运动状态下使用，寿命也会有所不同。因此额定寿命即用来定义钢基模组在操作过程中寿命的基准。

The life of a single-axis robot is highly dispersed. Even if the products manufactured in the same batch are used in the same motion state, the life will be different. So, rating life is the benchmark used to define the life of steel-based modules during operation.

3、钢基模组的额定寿命计算。Calculation of rated life of steel base module.

单轴机器人的寿命计算可分为两部分进行，包括直线导轨与滚珠螺杆，并以计算过程中数值较小者为该模组的额定寿命。其计算式分别如下：

The life calculation of single-axis robot can be divided into two parts, including linear guide rail and ball screw, and the rated life of the module is the one with the smaller value in the calculation process. The formulas are as follows:

线性滑轨 Linear slide rail

$$L = \left(\frac{f_t}{f_w} \cdot \frac{C}{P_n} \right)^3 \times 50 \text{ km}$$

L: 额定寿命 [公里km] L: Rated life [km]
 f_t: 接触系数 [参考表格1] f_t: Contact coefficient [refer to Table 1]
 f_w: 负荷系数 [参考表格2] f_w: Load factor [refer to Table 2]
 C: 基本动额定负荷 [N] C: Basic dynamic rated load [N]
 P_n: 工作负荷 [N] P_n: Workload [N]

表格1 Form 1

滑座型式 Sliding seat type	接触系数f _t Sliding seat type
A1, S1	1
A2, S2	0.81

表格2 Form 2

工作环境 Working environment		负荷系数f _w Load factor
负荷状况 Load condition	速度[V] Speed	
无冲击力且平滑 No impact and smooth	低速V Low speed V<15m: min	1~1.5
普通负荷力 Ordinary load force	中速15 Medium speed 15<V<60m: min	1.5~2
受冲击力及振动 Affected by impact force and vibration	高速V High speed v>60m: min	2~3.5

滚珠螺杆及轴承 Ball screw and bearing

$$L = \left(\frac{1}{f_w} \cdot \frac{C_a}{P_{a,n}} \right)^3 \times 10^6 \text{ rev}$$

L: 额定寿命 [旋转数] L: Rated life [rotation number]
 f_w: 负荷系数 [参考表格2] f_w: Load factor [refer to Table 2]
 C: 基本动额定负荷 [N] C: Basic dynamic rated load [N]
 P_n: 轴向工作负荷 [N] P_n: Axial working load [N]

润滑 Lubrication

钢基模组若没有适当的给予润滑，滚动部分的摩擦就会增加，长期的使用下来会成为缩短寿命的主要原因。润滑剂便提供下列几种作用：

- ✦ 减少滚动部分的摩擦、防止烧伤并降低磨损。
- ✦ 在滚动的面与面之间形成油膜，可延长滚动疲劳寿命。
- ✦ 防止生锈。

If the steel base module is not properly lubricated, the friction of rolling parts will increase, and the long-term use will be the main reason for shortening the life.

Lubricants provide the following functions:

- ✦ Reduce friction of rolling parts, prevent burns and reduce wear.
- ✦ Forming oil film between rolling surfaces can prolong the rolling fatigue life.
- ✦ Prevent rust.

1、润滑油脂。Lubricant grease

润滑油脂虽然较不易流失，但为避免因润滑损耗造成润滑不足，建议客户使用距离达100km时，应再补充润滑油脂一次，此时可用注油枪借由滑块上所附油嘴，将油脂打入滑块中。润滑油脂适用于速度不超过60m/min，且对冷却作用无要求的场合。

Although lubricating grease is not easy to be lost, in order to avoid insufficient lubrication caused by lubrication loss, it is suggested that customers should replenish lubricating grease I when the distance is 100km. Second, at this time, the grease gun can be used to drive the grease into the slider through the nozzle attached to the slider. Grease is suitable for speed less than 60m/min, and has no cooling effect. The occasion of the request.

$$T = \frac{100 \times 1000}{V_e \times 60}$$

T: 注油频率 [hour] T: Oil injection frequency [hour]
 V_e: 速度 [m/min] V_e: Speed [m/min]

2、油嘴配置图。Nozzle configuration diagram

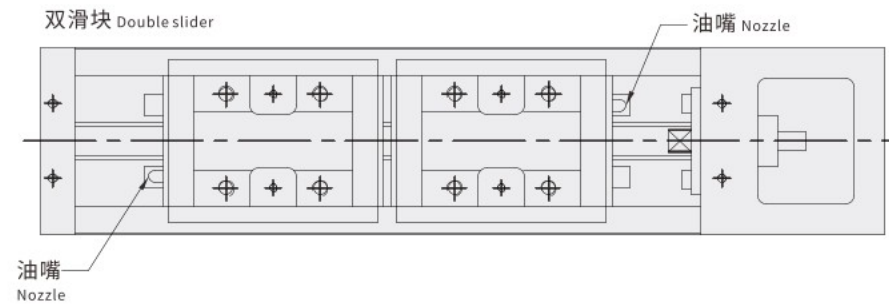
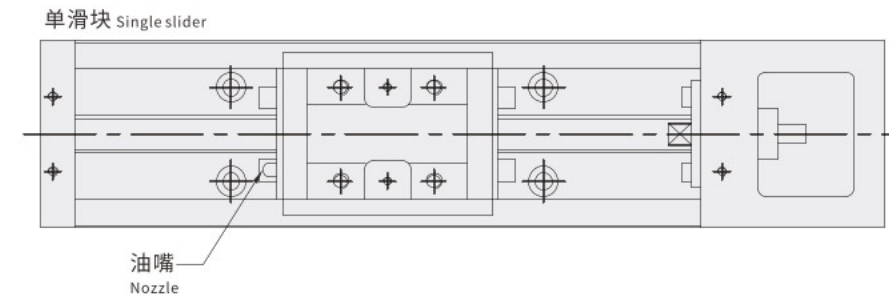

KSR使用油嘴
KSR uses oil nozzle.

KSR40

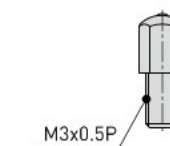

KSR50
KSR60
KSR86

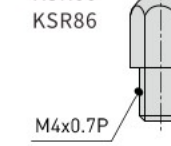

KSR100
KSR130

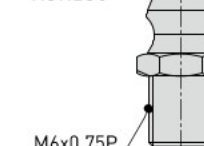



钢基内部结构图说明

Description of internal structure diagram of steel base

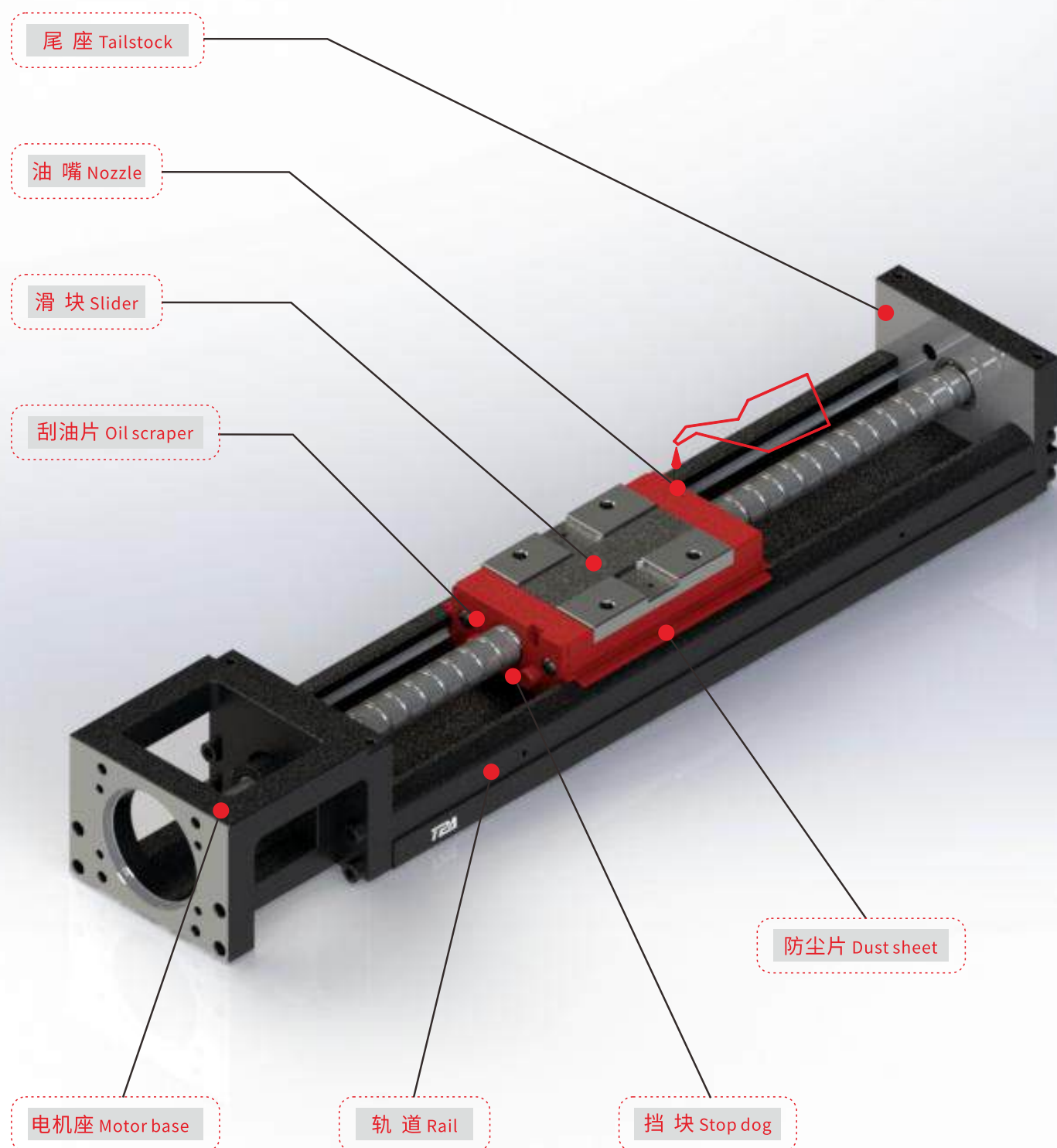

滚珠螺杆 Ball screw

由高精度的滚珠螺杆做为传动结构, 以及配合最佳化设计的U型轨道做为导引结构, 来确保精度与刚性需求。
The high-precision ball screw is used as the transmission structure, and the U-shaped track is matched with the optimized design. As a guide structure, to ensure the accuracy and rigidity requirements.

体积更小 Smaller size

宽度缩小, 让设备安装所需空间更小。
The width is reduced, so that the space required for equipment installation is smaller.

组装, 省时、方便 Easy assemble

将滚珠螺杆和U型轨道整合在一起, 因此可提供具有高精度、高刚性、快速安装等特性。
The ball screw and the U-shaped rail are integrated together, so tools can be provided. It has the characteristics of high precision, high rigidity and quick installation.

特性 Characteristics

- | | | |
|--------------------------------|-------------------|---------------------------|
| ①最简化设计。 | ②高刚性。 | ③配置齐全。 |
| ④体积小、重量轻。 | ⑤高精度。 | ⑥安装维护方便。 |
| ① Simplified design. | ② High rigidity. | ③ Complete configuration. |
| ④ Small size and light weight. | ⑤ High precision. | ⑥ Easy to install. |

应用领域 Application field

- | | |
|------------------|------------------------------------|
| ①FPD产业。 | ②医疗自动化产业。 |
| ③半导体。 | ④精密测量仪器。 |
| ① FPD industry. | ② Medical automation industry. |
| ③ semiconductor. | ④ Precision measuring instruments. |



主要特性

Key property

工业机器人 Industrial robot

- ✦ 模组化设计, 体积更小。
- ✦ 标准化生产, 交期快, 成本更低。
- ✦ U型钢基轨道, 局部淬火, HRC58度以上, 高强度, 高承载。
- ✦ 通用性高, 规格型号全, 适应各行业客户需要。
- ✦ 最优化设计。轨道结构由有限元素分析, 得到最好刚性及重量。
- ✦ Modular design, smaller size.
- ✦ Standardized production, fast delivery and lower cost.
- ✦ U-shaped steel base track, local quenching, HRC58 above 58 degrees, high strength, high load.
- ✦ High versatility, complete specifications and models, to meet the needs of customers in various industries.
- ✦ Optimal design. The track structure is analyzed by finite elements, and the best rigidity and weight are obtained.



1. 模组化 Modular

钢基模组透过模组化之设计, 整合滚珠螺杆和U型轨道, 可节省以往传统致动平台需经过导引和驱动元件之选用、安装校验、体积大、占空间等缺点因此钢基模组可提供快速选用、安装、体积精简、高刚性等特性, 可大幅减少客户端的使用空间与时间。
Through modular design, the steel base module integrates ball screw and U-shaped rail, which can save the traditional actuating platform from having to go through the selection of guiding and driving components, installation and verification, large volume and occupying space. Therefore, the steel-based module can provide the characteristics of quick selection, installation, compact size, high rigidity and so on, which can greatly reduce the use space and time of the client.

传统直线平台 Traditional linear platform

- 1平台 1Platform
- 2直线导轨 2Linear guide
- 1滚珠螺杆 1Ball screw
- 1底座 1Platform

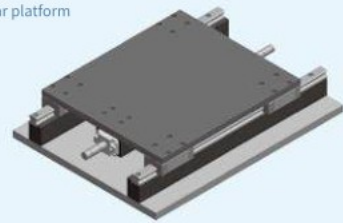

钢基模组 Steel base module

- 1滚珠螺杆 1Ball screw
- 1导轨 1Guide



2. 四方向等负荷 Four-direction equal load

轨道和滑块之间的回流系统, 其滚珠与珠槽接触面采用2列式歌德牙型之设计, 具有45度接触角之特性, 该设计可使得钢基模组可承受四方向等负荷之能力。

And the contact surface between the ball and the bead groove adopts a 2-row Goethe tooth type. The design has the characteristics of 45-degree contact angle, which enables the steel-based module to withstand four directions. The ability of equal load.

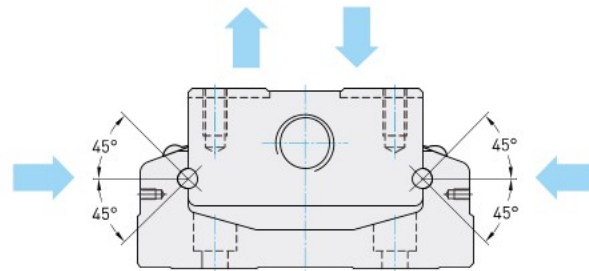

3. 规格全 Full line of specification

针对各种不同的使用需求, 开发出下列多种钢基模组系列模组提供客户依使用需求、空间、负载来选用。

According to various use requirements, the following series of steel-based modules have been developed for customers to choose according to use requirements, space and load.

型号 Model	W	H
TPA-KSR-30	30	15
TPA-KSR-40	40	20
TPA-KSR-50	50	26
TPA-KSR-60	60	33
TPA-KSR-86	86	46
TPA-KSR-100	100	55

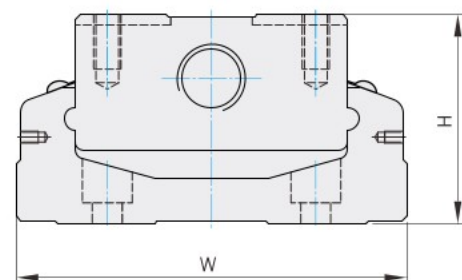

4. 高刚性 High rigidity

轨道构型采用U型断面, 并透过有限元素分析软体的设计, 在体积与刚性上取得平衡点, 使得轨道具有高刚性、体积精简、重量轻等特性。
The configuration of the track adopts U-shaped section, and through the design of finite element analysis software, the balance between volume and rigidity is achieved, which makes the track have the characteristics of high rigidity, compact volume and light weight.

惯性矩 Moment of inertia 单位Unit:mm⁴

型号 Model	I _x	I _y
TPA-KSR-30	7.554x10 ²	12.726x10 ³
TPA-KSR-40	3.533x10 ³	5.137x10 ⁴
TPA-KSR-50	9.6x10 ³	1.34x10 ⁵
TPA-KSR-60	5.056x10 ⁴	2.802x10 ⁵
TPA-KSR-86	7.455x10 ⁴	1.134x10 ⁶
TPA-KSR-100	1.296x10 ⁵	2.035x10 ⁶

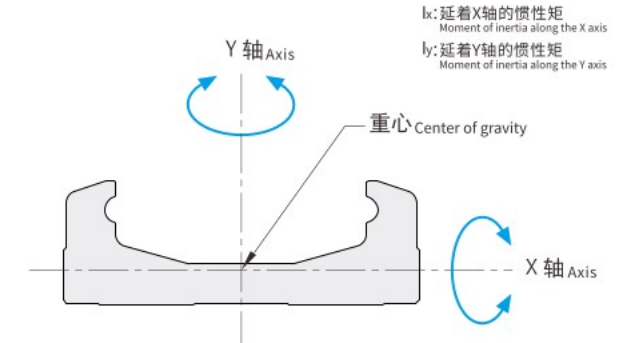

5. 选购配件 Accessories selection

为了因各种的使用需求, 可另外选购铝护盖、伸缩护套、电机连接法兰、极限开关。

- ✦ 铝护盖、伸缩护套: 可防止异物、杂质进入工业机器人的内部而影响其使用寿命、精度、顺畅度。
 - ✦ 电机连接法兰: 可将各种不同电机锁在工业机器人上。
 - ✦ 极限开关: 提供滑块定位、启动原点以及防止滑块超过行程的安全机制。
- For various use requirements, aluminum protective cover, telescopic sheath, motor connecting flange and limit switch can be purchased separately.
- ✦ Aluminum protective cover and telescopic sheath: It can prevent foreign matter and impurities from entering the interior of industrial robot and affecting its service life, accuracy and smoothness.
 - ✦ Motor connecting flange: various motors can be locked on industrial robots.
 - ✦ Limit switch: provides a safety mechanism for positioning the slider, starting the origin and preventing the slider from exceeding the stroke.

• 铝护盖型 Aluminum cover type

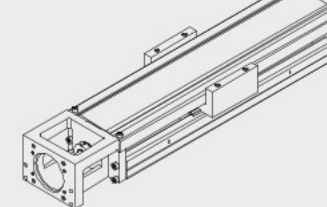

• 伸缩护套型 Guideway Cover

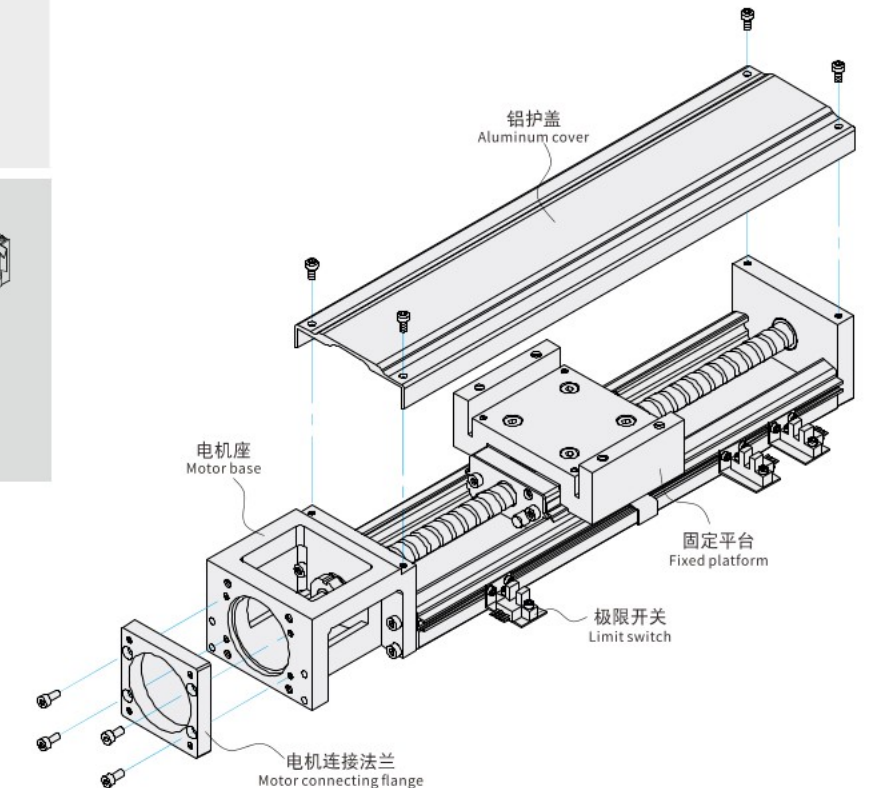
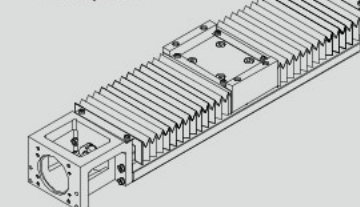

HNR
HCR
HNB
HCB
HNT
XYZ
ONB
OCB
GCR
GCB
GCBS
GCRS
ESR
EMR
EHR
KSR
LNP
DDR

参考资料
Reference data

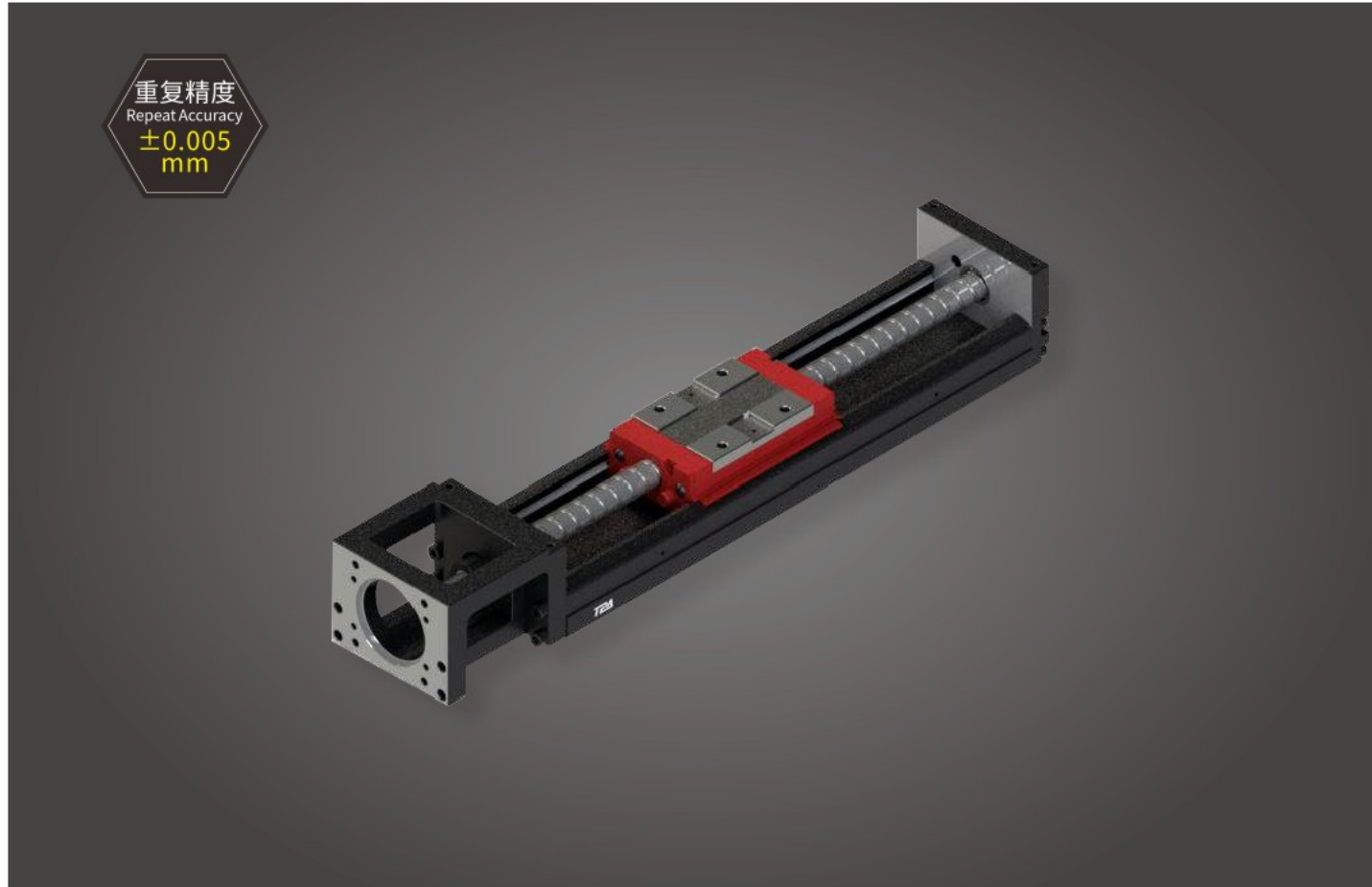

重复精度
Repeat Accuracy
±0.005 mm

此图仅供参考, 出货规格详见尺寸图面
This picture for reference only, specs details according with the drawing.

最大行程
Max Stroke 156mm

最高速度
Max Speed 50mm/sec

滚珠螺杆
Ball Screw Ø6 mm

型号表达方式 Ordering method

TPA-KSR-3001CK-100A1-M-F0S2-N3-D-F

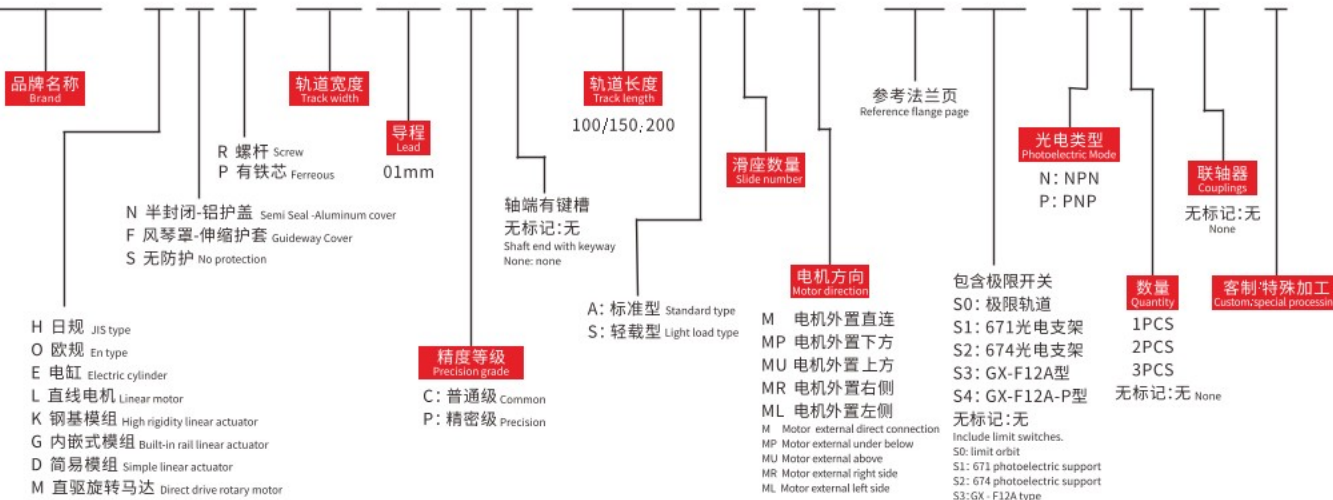

负载规格 Load specification

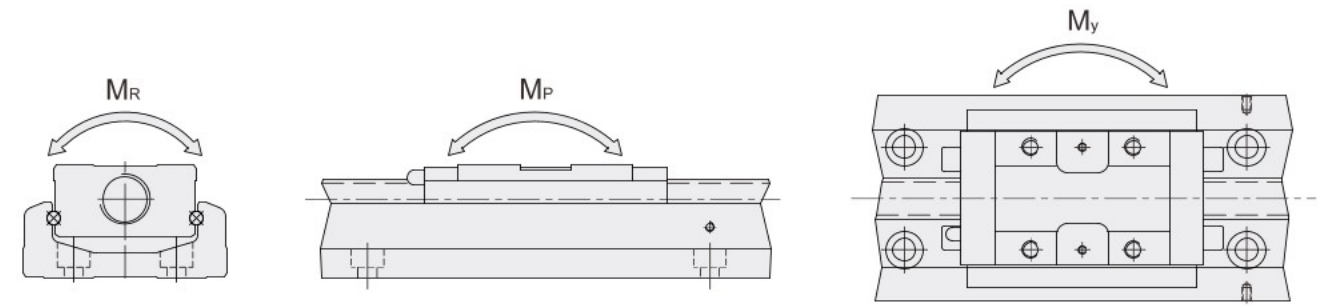

技术参数 Technical parameter

型号 Model	滚珠螺杆 Ballscrew				线性滑轨 Linear slider rail																
	公称外径 (mm)	导程 (mm)	基本动态额定负载 (N)	基本静态额定负载 (N)	容许静力矩 Allowable static moment																
					基本动态额定负载 (N) Basic dynamic rated load				俯仰 My (N-m)				偏摆 My (N-m)				滚动 Mz (N-m)				
KSR 3001	精密级 Precise grade	6	1	647	1088	滑座 A Slide carriage	滑座 S Slide carriage	滑座 A Slide carriage	滑座 S Slide carriage	滑座 A1 Slide carriage	滑座 A2 Slide carriage	滑座 S1 Slide carriage	滑座 S2 Slide carriage	滑座 A1 Slide carriage	滑座 A2 Slide carriage	滑座 S1 Slide carriage	滑座 S2 Slide carriage	滑座 A1 Slide carriage	滑座 A2 Slide carriage	滑座 S1 Slide carriage	滑座 S2 Slide carriage
	一般级 General grade			618	1079	2210	-	3510	-	14	73	-	-	14	73	-	-	41	82	-	-

精度等级 Precision grade

型号 Model	轨道长度 Track length	定位重现性 Positioning reproducibility		定位精度 Positioning accuracy		行走平行度 Walking parallelism		最大启动扭力 (N-cm) Maximum starting torque	
		精密级 Precise grade	一般级 General grade	精密级 Precise grade	一般级 General grade	精密级 Precise grade	一般级 General grade	精密级 Precise grade	一般级 General grade
KSR 30	75	±0.003	±0.004	0.020	0.040	0.010	0.020	1.2	0.8
	100								
	125								
	150								
	175								
200									

最大速度 Maximum speed

型号 Model	滚珠螺杆导程 (mm) Ballscrew lead	轨道长度 L2 (mm) Track length	速度 (mm/sec) Speed	
			精密级 Precise grade	一般级 General grade
KSR 30	01	75	160	160
		100	160	160
		125	160	160
		150	160	160
		175	160	160
200	160	160		



外形尺寸(不含护盖)/电机座与电机连接法兰
Overall dimensions(without cover)/Motor seat and motor connecting flange

M KSR-30 电机外置直连(不含护盖) KSR-30 Motor external direct connection (without cover) 单位:Unit: mm

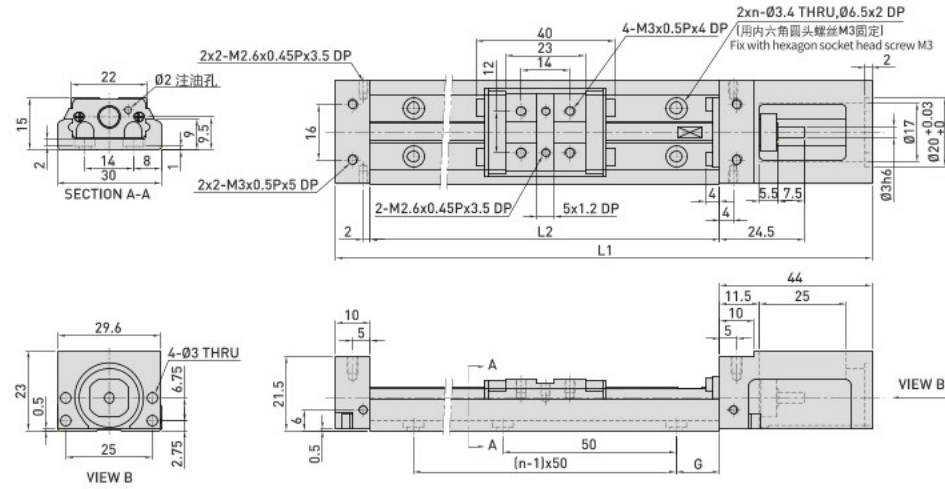

轨道长度 L2 Track length	全长(L1) Full length	最大行程(mm) Maximum travel		G(mm)	n	重量(kg) Weight	
		滑座 A1 Slide carriage	滑座 A2 Slide carriage			滑座 A1 Slide carriage	滑座 A2 Slide carriage
75	129	31	-	12.5	2	0.2	-
100	154	56	-	25	2	0.23	-
125	179	81	45	12.5	3	0.26	0.3
150	204	106	70	25	3	0.29	0.33
175	229	131	95	12.5	4	0.32	0.36
200	254	156	120	25	4	0.35	0.39

M KNR-30 电机外置直连(含护盖) KNR-30 Motor external direct connection (Cover included)

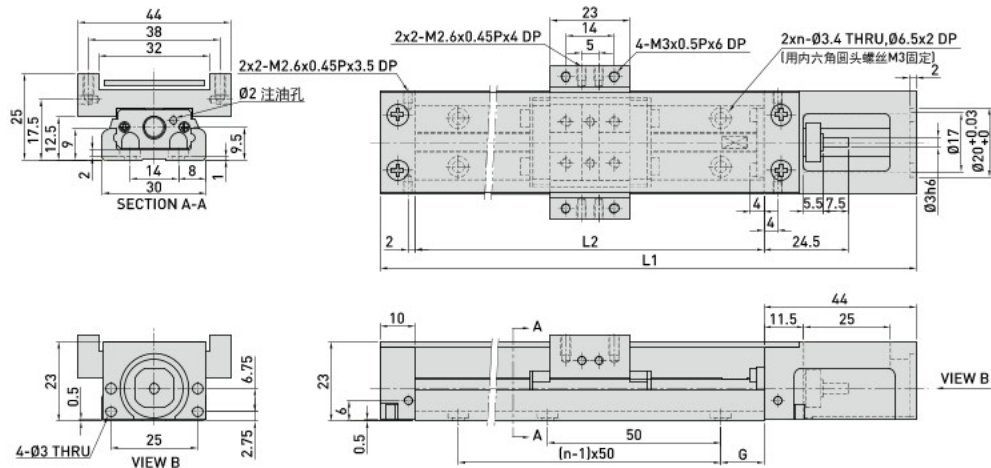

轨道长度 L2 Track length	全长(L1) Full length	最大行程(mm) Maximum travel		G(mm)	n	重量(kg) Weight	
		滑座 A1 Slide carriage	滑座 A2 Slide carriage			滑座 A1 Slide carriage	滑座 A2 Slide carriage
75	129	31	-	12.5	2	0.24	-
100	154	56	-	25	2	0.27	-
125	179	81	45	12.5	3	0.3	0.36
150	204	106	70	25	3	0.33	0.39
175	229	131	95	12.5	4	0.37	0.43
200	254	156	120	25	4	0.4	0.46

电机座与电机连接法兰
Motor seat and motor connecting flange

30 电机座F0 Motor seat F0

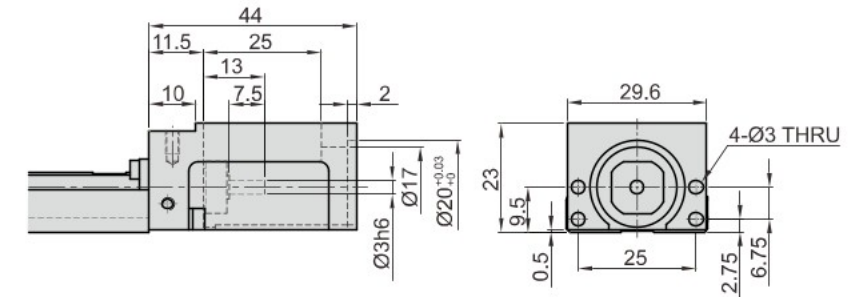

电机连接法兰F1 Connecting flange F1 of motor

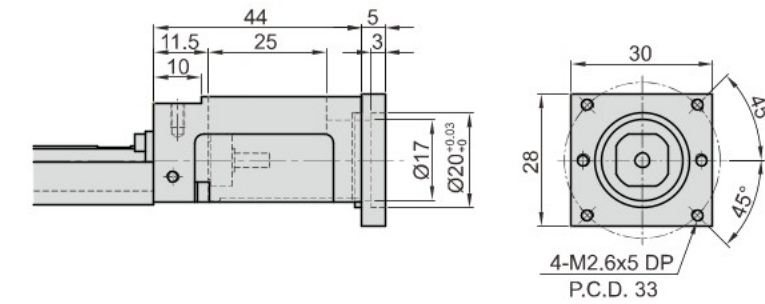

30 电机连接法兰F2 Connecting flange F2 of motor

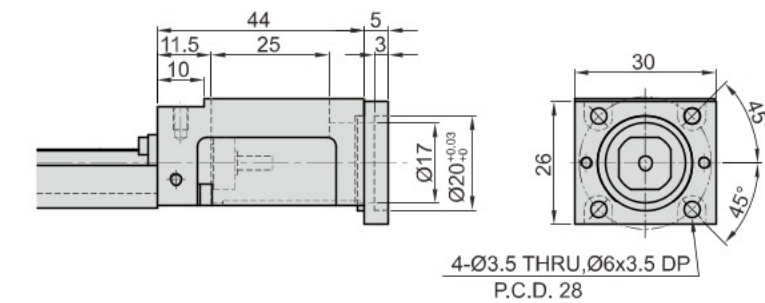

电机连接法兰F3 Connecting flange F3 of motor

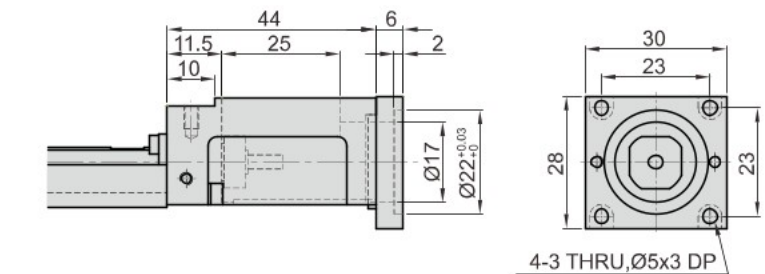

HNR
HCR
HNB
HCB
HNT
XYZ
ONB
OCB
GCR
GCB
GCBS
GCRS
ESR
EMR
EHR
KSR
LNP
DDR
参考资料
Reference data

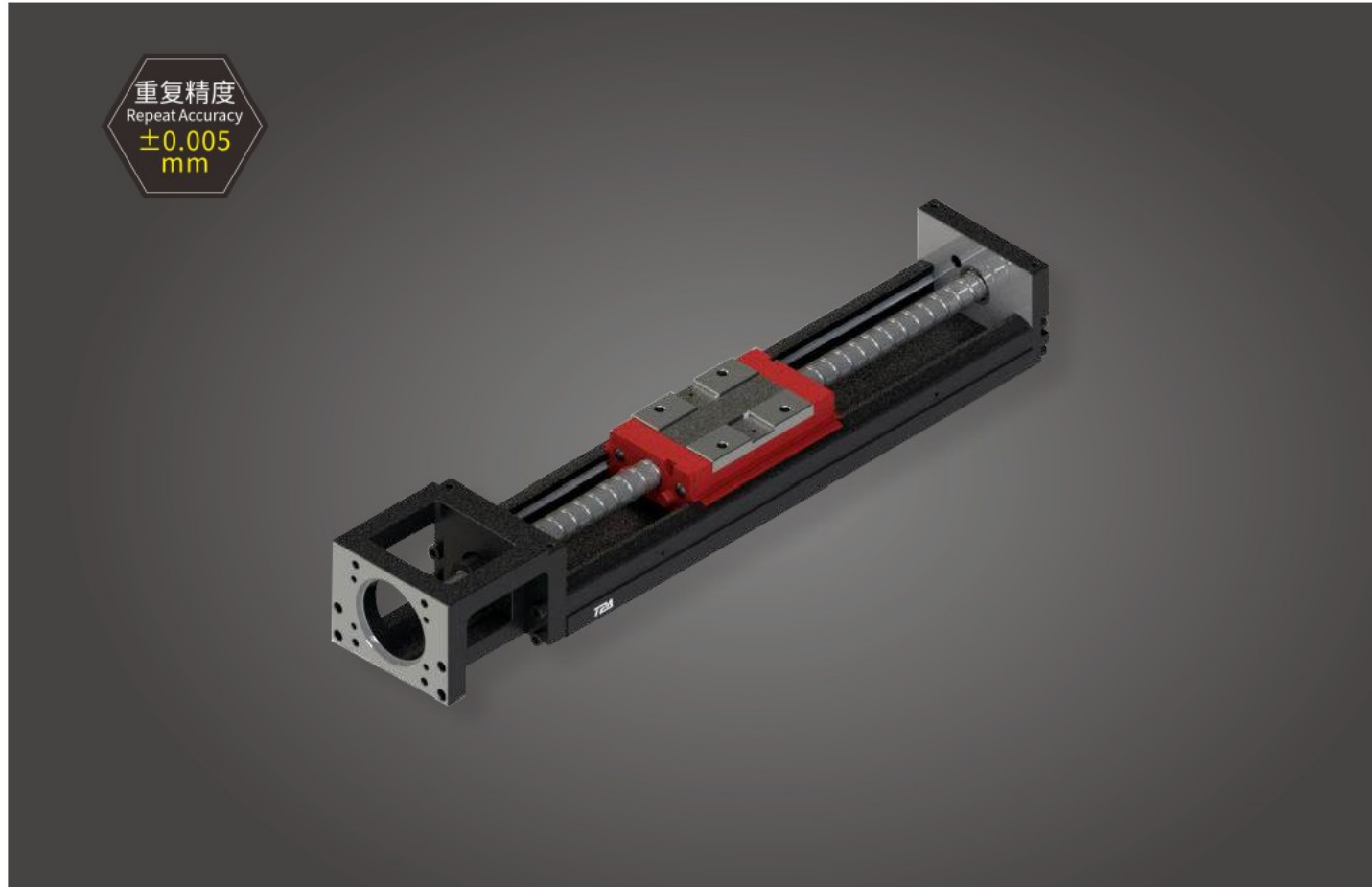

重复精度
Repeat Accuracy
 ± 0.005
mm

此图仅供参考, 出货规格详见尺寸图面
This picture for reference only, specs details according with the drawing.

最大行程
Max Stroke 136mm

最高速度
Max Speed 100mm/sec

滚珠螺杆
Ball Screw $\varnothing 8$ mm

型号表达方式 Ordering method

TPA-KSR-4001CK-100A1-M-F0S2-N3-D-F

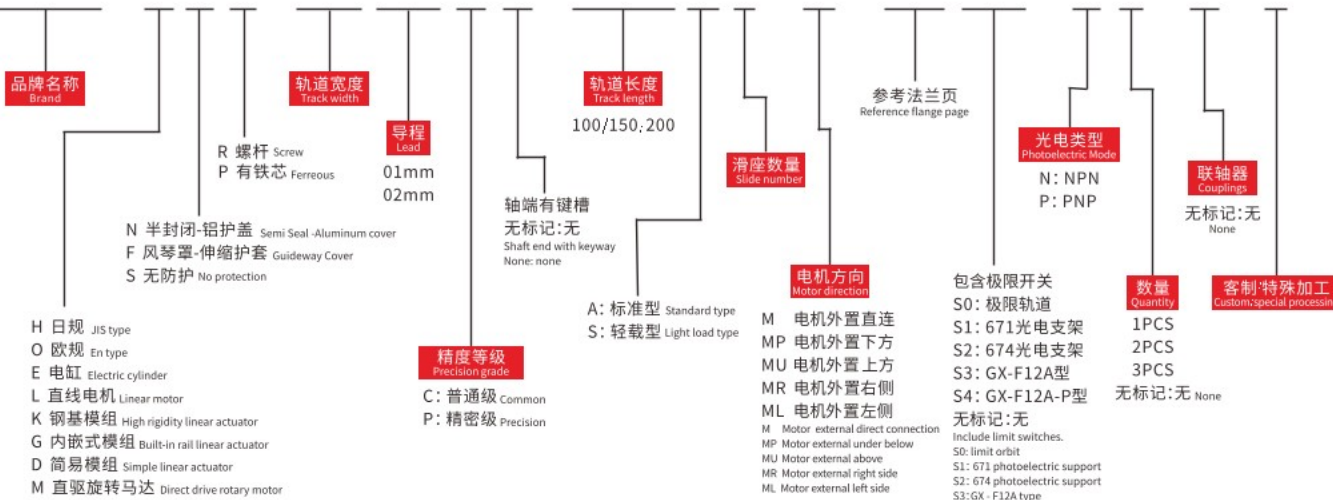

负载规格 Load specification

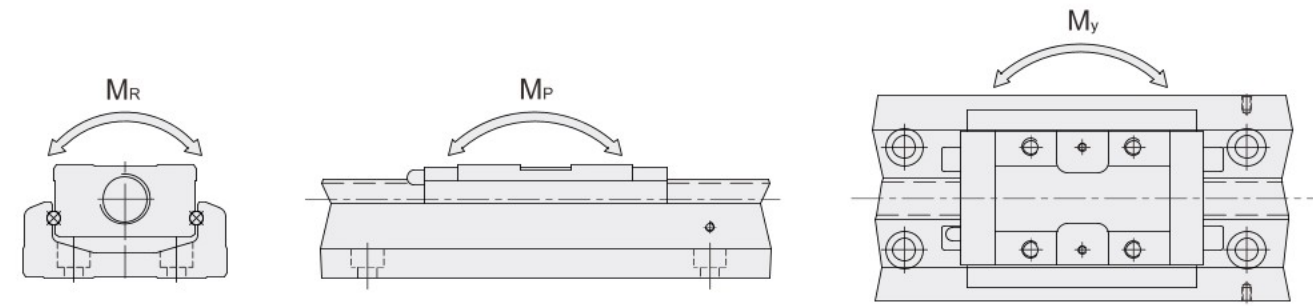

技术参数 Technical parameter

型号 Model	滚珠螺杆 Ballscrew				线性滑轨 Linearsliderail											
	公称外径 (mm)	导程 (mm)	基本动态额定负荷 (N)	基本静态额定负荷 (N)	容许静力矩 Allowable static moment											
					基本动态额定负荷 (N) Basic dynamic rated load				基本静态额定负荷 (N) Basic static rated load				容许静力矩 Allowable static moment			
KSR 4001	8	1	735	1538	容许静力矩 Allowable static moment				容许静力矩 Allowable static moment				容许静力矩 Allowable static moment			
			676	1284	容许静力矩 Allowable static moment				容许静力矩 Allowable static moment				容许静力矩 Allowable static moment			

精度等级 Precision grade

型号 Model	轨道长度 Track length	定位重现性 Positioning reproducibility		定位精度 Positioning accuracy		行走平行度 Walking parallelism		最大启动扭力: (N-cm) Maximum starting torque	
		精密级 Precise grade	一般级 General grade	精密级 Precise grade	一般级 General grade	精密级 Precise grade	一般级 General grade	精密级 Precise grade	一般级 General grade
KSR 40	100	± 0.003	± 0.005	0.020	-	0.010	-	1.2	0.8
	150								
	200								

最大速度 Maximum speed

型号 Model	滚珠螺杆导程 (mm) Ballscrew lead	轨道长度 L2 (mm) Track length	速度 (mm/sec) Speed	
			精密级 Precise grade	一般级 General grade
KSR 40	01	100	190	190
		150	190	190
		200	190	190



M KSR 外形尺寸(不含护盖)/KNR 外形尺寸(含护盖)
KSR Overall dimensions(without cover);KNR Overall dimensions(cover included)

M KSR-40 电机外置直连(不含护盖) KSR-40 Motor external direct connection (without cover) 单位:Unit: mm

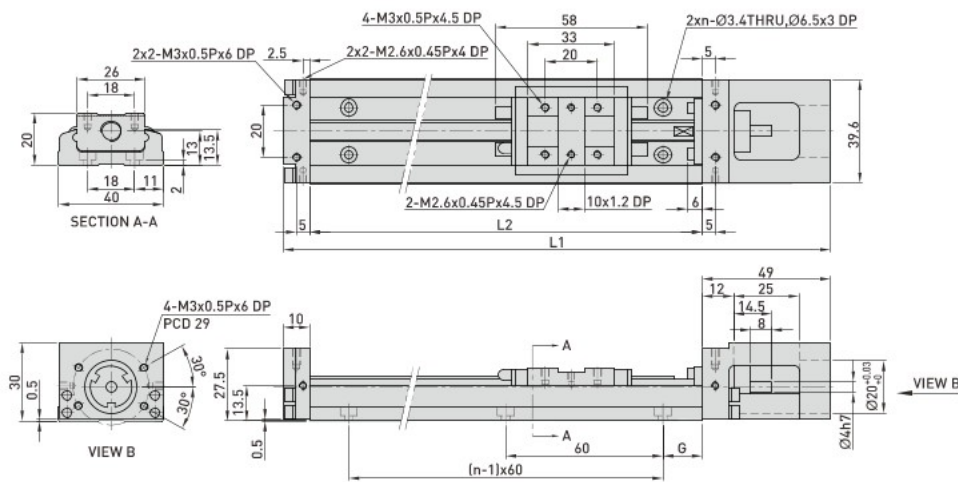

轨道长度 L2 Track length	全长(L1) Full length	最大行程(mm) Maximum travel		G(mm)	n	重量(kg) Weight	
		滑座 A1 Slide carriage	滑座 A2 Slide carriage			滑座 A1 Slide carriage	滑座 A2 Slide carriage
100	159	36	-	20	2	0.48	-
150	209	86	34	15	3	0.6	0.67
200	259	136	84	40	3	0.72	0.79

M KNR-40 电机外置直连(含护盖) KNR-40 Motor external direct connection (Cover included) 单位:Unit: mm

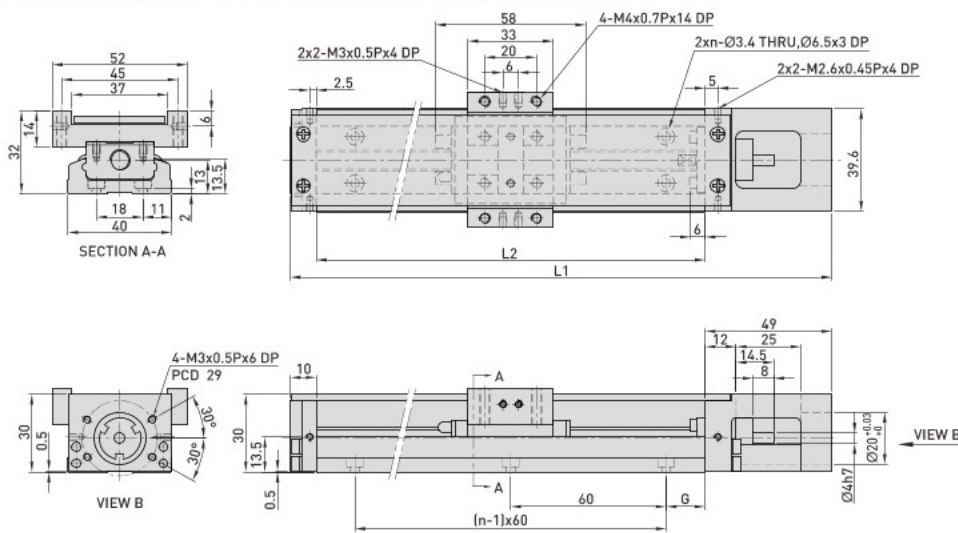

轨道长度 L2 Track length	全长(L1) Full length	最大行程(mm) Maximum travel		G(mm)	n	重量(kg) Weight	
		滑座 A1 Slide carriage	滑座 A2 Slide carriage			滑座 A1 Slide carriage	滑座 A2 Slide carriage
100	159	36	-	20	2	0.55	-
150	209	86	34	15	3	0.68	0.76
200	259	136	84	40	3	0.82	0.89

电机座与电机连接法兰
Motor seat and motor connecting flange

40 电机座 F0 Motor seat F0

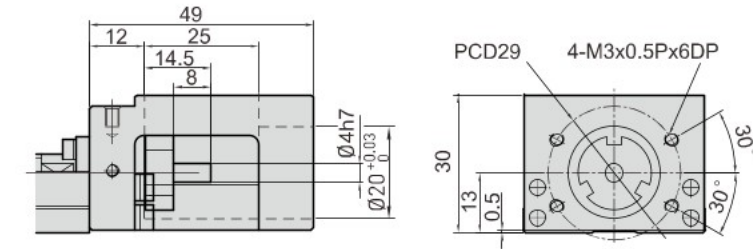

电机连接法兰 F1 Connecting flange F1 of motor

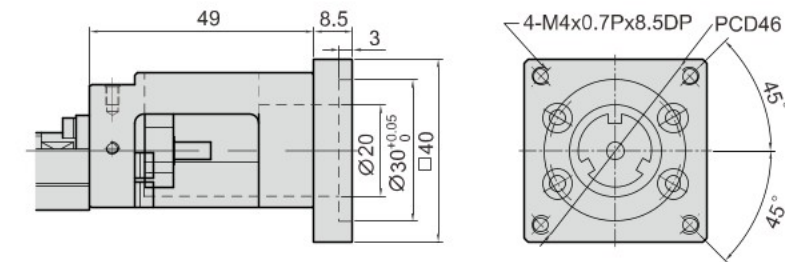

40 电机连接法兰 F2 Connecting flange F2 of motor

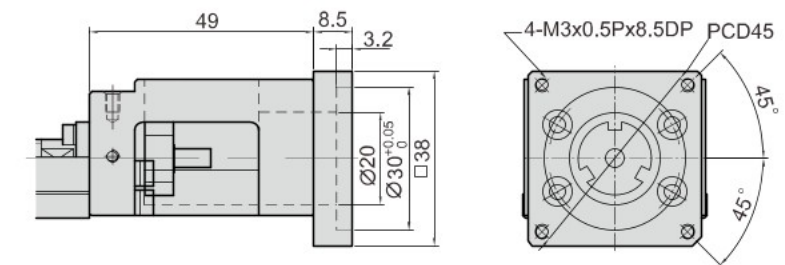

电机连接法兰 F3 Connecting flange F3 of motor

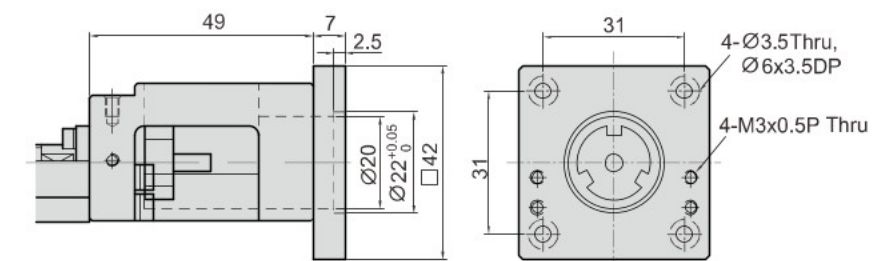

- HNR
- HCR
- HNB
- HCB
- HNT
- XYZ
- ONB
- OCB
- GCR
- GCB
- GCBS
- GCRS
- ESR
- EMR
- EHR
- KSR**
- LNP
- DDR
- 参考资料
Reference data



电机座与电机连接法兰
Motor seat and motor connecting flange

40 转接固定H0 Fixed transfer H0

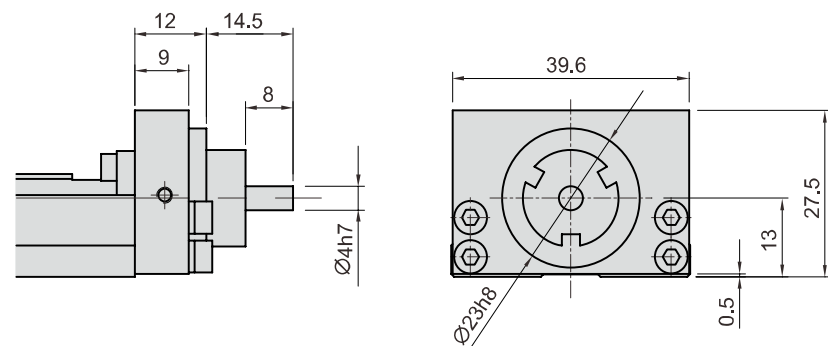

MEMO

- HNR
- HCR
- HNB
- HCB
- HNT
- XYZ
- ONB
- OCB
- GCR
- GCB
- GCBS
- GCRS
- ESR
- EMR
- EHR
- KSR**
- LNP
- DDR
- 参考资料
Reference
data



KSR外形尺寸(不含护盖)/KNR外形尺寸(含护盖)
KSR Overall dimensions(without cover):KNR Overall dimensions(cover included)

M KSR-50 电机外置直连(不含护盖) KSR-50 Motor external direct connection (without cover) 单位:Unit: mm

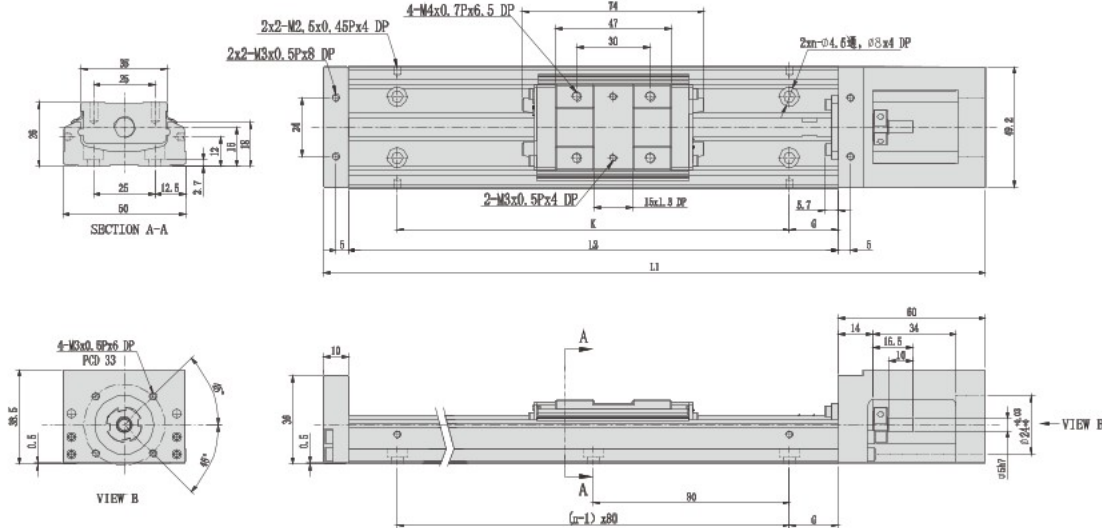

轨道长度 L2 Track length	全长(L1) Full length	最大行程(mm) Maximum travel		G(mm)	K(mm)	n	重量(kg) Weight	
		滑座 A1 Slide carriage	滑座 A2 Slide carriage				滑座 A1 Slide carriage	滑座 A2 Slide carriage
150	220	70	-	35	80	2	1	-
200	270	120	55	20	160	3	1.2	1.4
250	320	170	105	45	160	3	1.4	1.6
300	370	220	155	30	240	4	1.6	1.8

M KNR-50 电机外置直连(含护盖) KNR-50 Motor external direct connection (Cover included) 单位:Unit: mm

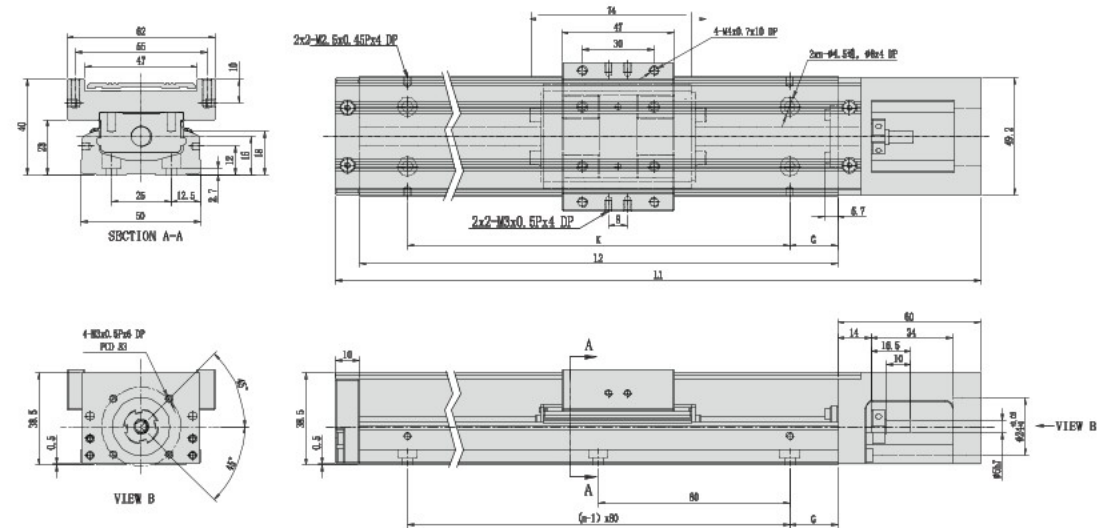

轨道长度 L2 Track length	全长(L1) Full length	最大行程(mm) Maximum travel		G(mm)	K(mm)	n	重量(kg) Weight	
		滑座 A1 Slide carriage	滑座 A2 Slide carriage				滑座 A1 Slide carriage	滑座 A2 Slide carriage
150	220	70	-	35	80	2	1.1	-
200	270	120	55	20	160	3	1.3	1.5
250	320	170	105	45	160	3	1.6	1.8
300	370	220	155	30	240	4	1.8	2

电机座与电机连接法兰
Motor seat and motor connecting flange

50 电机座F0 Motor seat F0

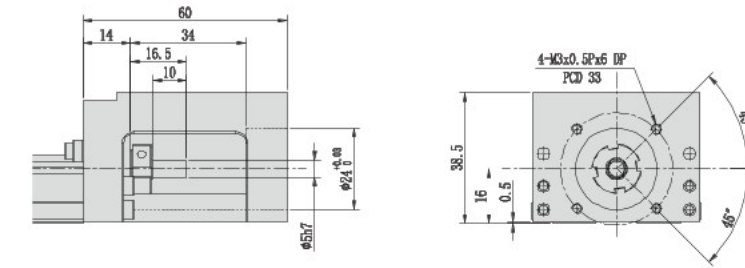

电机座H0 Motor seat H0

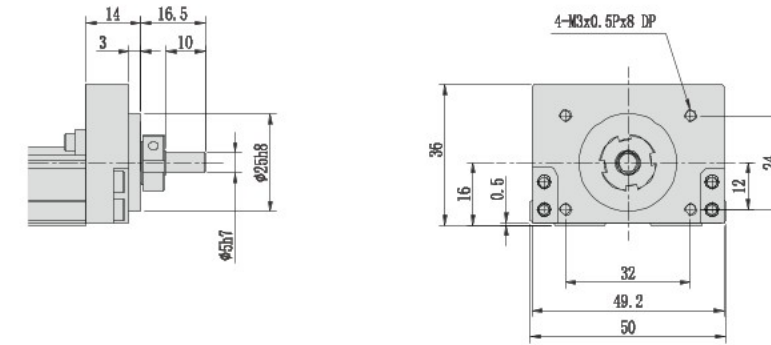

50 电机连接法兰F1(台达/安川/汇川/三菱/富士 100W) Connecting flange F1 of motor (Delta/Yaskawa/Inovance/Mitsubishi/Fuji 100W)

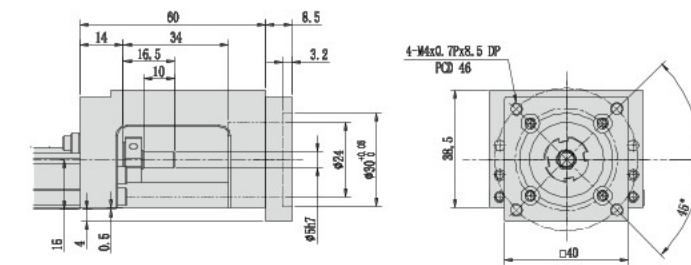

电机连接法兰F2(松下 50W/100W) Connecting flange F2 of motor (Panasonic 50W/100W)

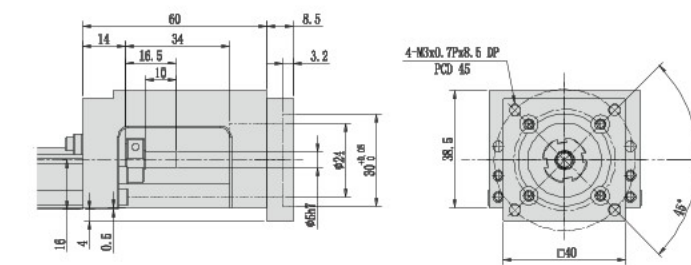

- HNR
- HCR
- HNB
- HCB
- HNT
- XYZ
- ONB
- OCB
- GCR
- GCB
- GCBS
- GCRS
- ESR
- EMR
- EHR
- KSR**
- LNP
- DDR
- 参考资料
Reference data



电机座与电机连接法兰
Motor seat and motor connecting flange

50 电机连接法兰F3(42步进) Connecting flange F3 of motor (42 Stepper)

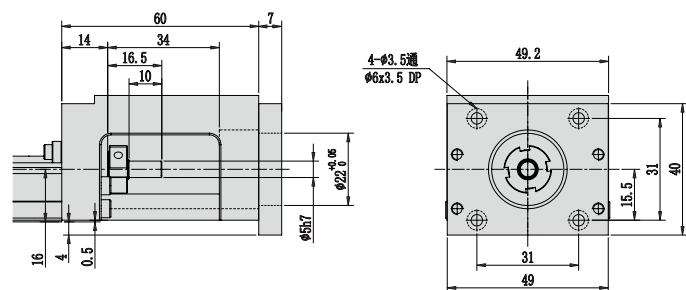

MEMO

- HNR
- HCR
- HNB
- HCB
- HNT
- XYZ
- ONB
- OCB
- GCR
- GCB
- GCBS
- GCRS
- ESR
- EMR
- EHR
- KSR**
- LNP
- DDR
- 参考资料
Reference data



重复精度
Repeat Accuracy
±0.005 mm

此图仅供参考, 出货规格详见尺寸图面
This picture for reference only, specs details according with the drawing.

最大行程
Max Stroke 510mm

最高速度
Max Speed 1000mm/sec

滚珠螺杆
Ball Screw Ø 12 mm

型号表达方式 Ordering method

TPA-KSR-6010CK-200A1-M-F0S2-N3-D-F

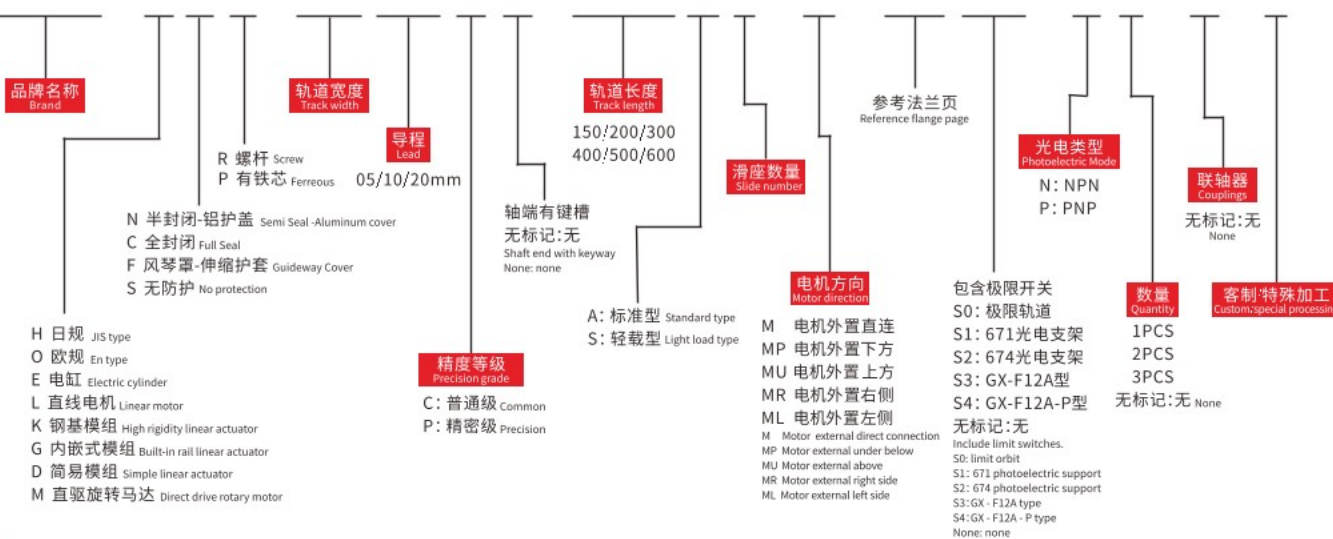

负载规格 Load specification

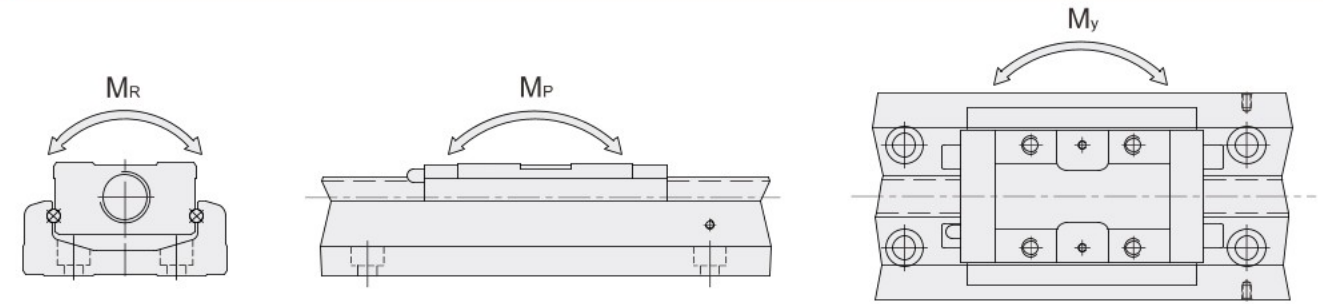

技术参数 Technical parameter

型号 Model	滚珠螺杆 Ballscrew				线性滑轨 Linear sliderail															
	公称外径 (mm)	导程 (mm)	基本动态额定负荷 (N)	基本静态额定负荷 (N)	基本动态额定负荷 (N)		基本静态额定负荷 (N)		容许静力矩 Allowable static moment											
					滑座 A	滑座 S	滑座 A	滑座 S	俯仰 M _P (N·m)			偏扭 M _Y (N·m)			滚动 M _R (N·m)					
KSR 6005	12	5	3744	6243	13230	7173	21462	11574	152	760	72	367	152	760	72	367	419	838	241	482
KSR 6010	12	10	2410	3743	13230	7173	21462	11574	152	760	72	367	152	760	72	367	419	838	241	482
KSR 6020	12	20	1610	2872	13230	7173	21462	11574	152	760	72	367	152	760	72	367	419	838	241	482

精度等级 Precision grade

型号 Model	轨道长度 Track length	定位重现性 Positioning reproducibility		定位精度 Positioning accuracy		行走平行度 Walking parallelism		最大启动扭力 (N·cm) Maximum starting torque	
		精密级 Precise grade	一般级 General grade	精密级 Precise grade	一般级 General grade	精密级 Precise grade	一般级 General grade	精密级 Precise grade	一般级 General grade
		KSR 60	150	±0.003	±0.005	0.020	-	0.010	-
	200								
	300								
	400								
	500								
	600	±0.003	±0.005	0.025	-	0.015	-	15	7

最大速度 Maximum speed

型号 Model	滚珠螺杆导程 (mm) Ballscrew lead	轨道长度 L2 (mm) Track length	速度 (mm/sec) Speed	
			精密级 Precise grade	一般级 General grade
KSR 60	05	150	550	390
		200	550	390
		300	550	390
		400	550	390
		500	550	390
		600	340	340
	10	150	1100	790
		200	1100	790
		300	1100	790
		400	1100	790
		500	1100	790
		600	670	670
20	150	-	1000	
	200	-	1000	
	300	-	1000	
	400	-	1000	
	500	-	1000	
	600	-	850	

KSR 外形尺寸(不含护盖)
KSR Overall dimensions(without cover)

MU KSR-60 电机外置上方(不含护盖) KSR-60 Motor external above (without cover) 单位:Unit: mm

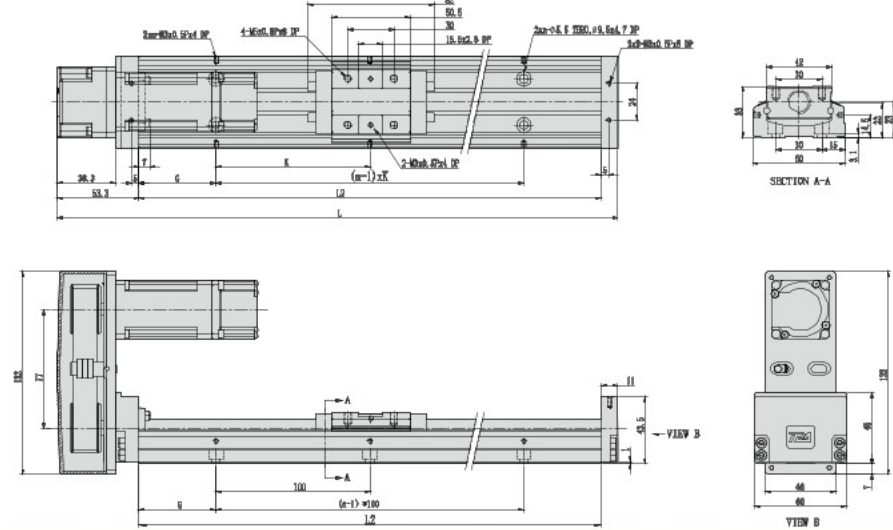

轨道长度 L2 Track length	全长(L1) Full length	最大行程(mm) Maximum travel		G(mm)	K(mm)	n	m	重量(kg) Weight	
		滑座 A1 Slide carriage	滑座 A2 Slide carriage					滑座 A1 Slide carriage	滑座 A2 Slide carriage
150	214.3	60	-	25	100	2	2	1.4	-
200	264.3	110	-	50	100	2	2	1.7	-
300	364.3	210	135	50	200	3	2	2.3	2.6
400	464.3	310	235	50	100	4	4	3.2	3.2
500	564.3	410	335	50	200	5	3	3.5	3.8
600	664.3	510	435	50	100	6	6	4.1	4.5

KNR 外形尺寸(含护盖)
KNR Overall dimensions(Cover included)

M KNR-60 电机外置直连(含护盖) KNR-60 Motor external direct connection (Cover included) 单位:Unit: mm

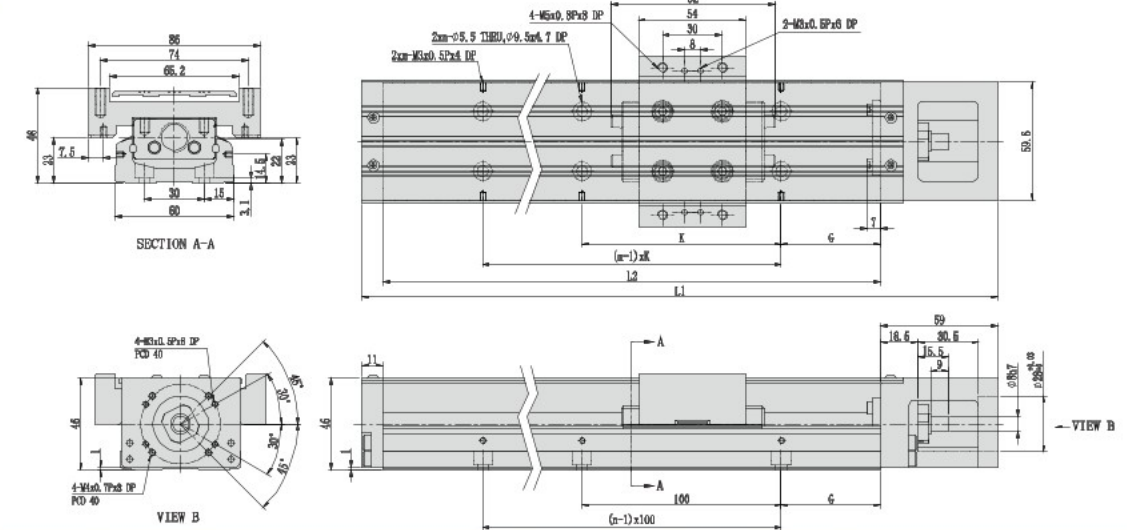

轨道长度 L2 Track length	全长(L1) Full length	最大行程(mm) Maximum travel		G(mm)	K(mm)	n	m	重量(kg) Weight	
		滑座 A1 Slide carriage	滑座 A2 Slide carriage					滑座 A1 Slide carriage	滑座 A2 Slide carriage
150	220	60	-	25	100	2	2	1.7	-
200	270	110	-	50	100	2	2	2.1	-
300	370	210	135	50	200	3	2	2.7	3
400	470	310	235	50	100	4	4	3.3	3.6
500	570	410	335	50	200	5	3	3.9	4.2
600	670	510	435	50	100	6	6	4.6	5

MP KSR-60 电机外置下方(不含护盖) KSR-60 Motor external under below (without cover) 单位:Unit: mm

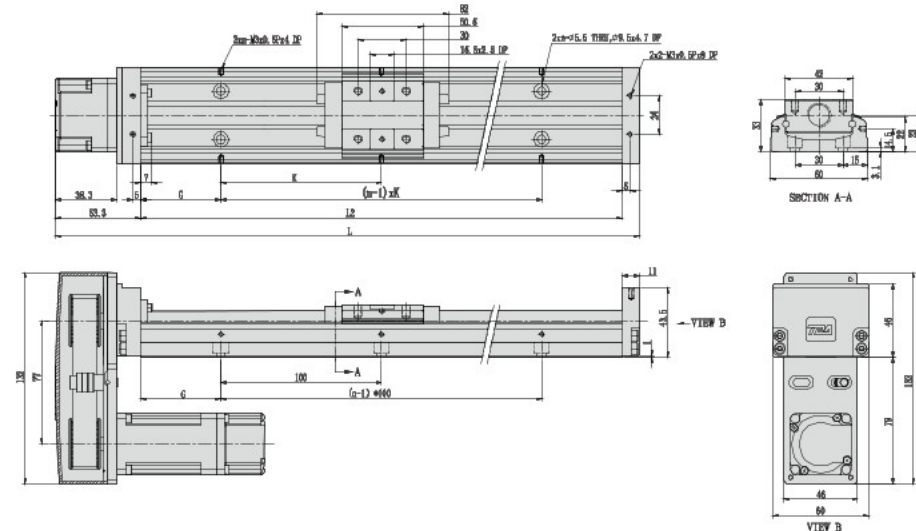

轨道长度 L2 Track length	全长(L1) Full length	最大行程(mm) Maximum travel		G(mm)	K(mm)	n	m	重量(kg) Weight	
		滑座 A1 Slide carriage	滑座 A2 Slide carriage					滑座 A1 Slide carriage	滑座 A2 Slide carriage
150	214.3	60	-	25	100	2	2	1.4	-
200	264.3	110	-	50	100	2	2	1.7	-
300	364.3	210	135	50	200	3	2	2.3	2.6
400	464.3	310	235	50	100	4	4	3.2	3.2
500	564.3	410	335	50	200	5	3	3.5	3.8
600	664.3	510	435	50	100	6	6	4.1	4.5

H0 KNR-60-H0(含护盖) KNR-60-H0 (including cover) 单位:Unit: mm

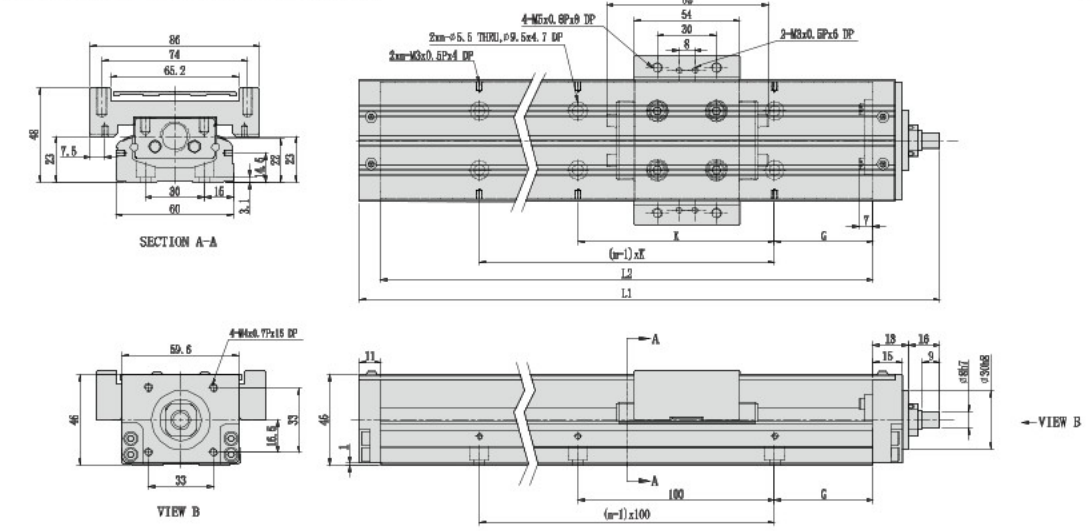

轨道长度 L2 Track length	全长(L1) Full length	最大行程(mm) Maximum travel		G(mm)	K(mm)	n	m	重量(kg) Weight	
		滑座 A1 Slide carriage	滑座 A2 Slide carriage					滑座 A1 Slide carriage	滑座 A2 Slide carriage
150	195	60	-	25	100	2	2	1.6	-
200	245	110	-	50	100	2	2	2	-
300	345	210	135	50	200	3	2	2.6	2.9
400	445	310	235	50	100	4	4	3.2	3.5
500	545	410	335	50	200	5	3	3.8	4.1
600	645	510	435	50	100	6	6	4.5	4.9

HNR
HCR
HNB
HCB
HNT
XYZ
ONB
OCB
GCR
GCB
GCBS
GCRS
ESR
EMR
EHR
KSR
LNP
DDR

参考资料
Reference data

KNR 外形尺寸(含护盖)
KNR Overall dimensions(Cover included)

MR KNR-60 电机外置右侧(含护盖) KNR-60 Motor external right side (Cover included)

单位:Unit: mm

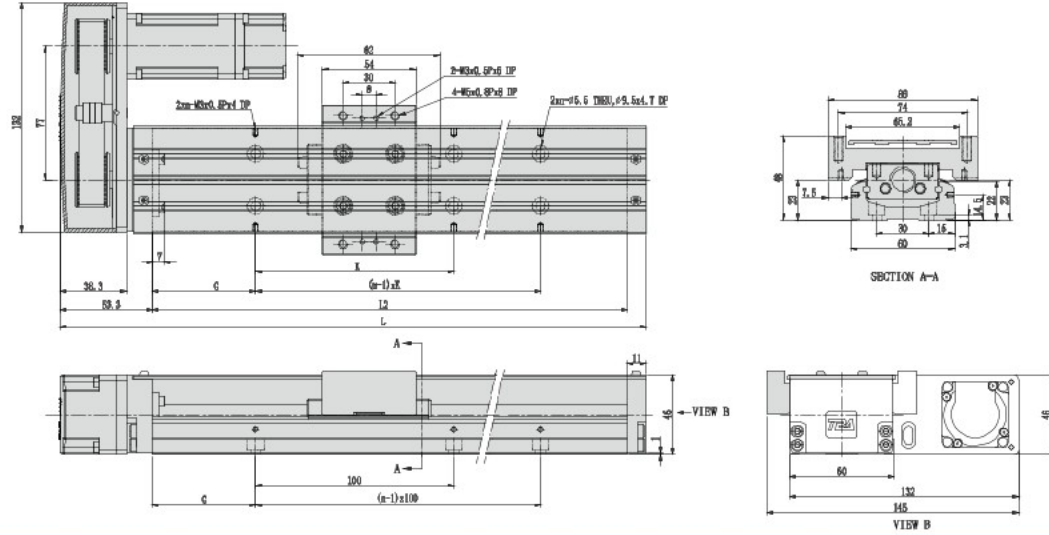

轨道长度 L2 Track length	全长(L1) Full length	最大行程(mm) Maximum travel		G(mm)	K(mm)	n	m	重量(kg) Weight	
		滑座 A1 Slide carriage	滑座 A2 Slide carriage					滑座 A1 Slide carriage	滑座 A2 Slide carriage
150	214.3	60	-	25	100	2	2	1.6	-
200	264.3	110	-	50	100	2	2	2	-
300	364.3	210	135	50	200	3	2	2.6	2.9
400	464.3	310	235	50	100	4	4	3.2	3.5
500	564.3	410	335	50	200	5	3	3.8	4.1
600	664.3	510	435	50	100	6	6	4.5	4.9

KNR 外形尺寸(含护盖)
KNR Overall dimensions(Cover included)

MU KNR-60 电机外置上方(含护盖) KNR-60 Motor external above (Cover included)

单位:Unit: mm

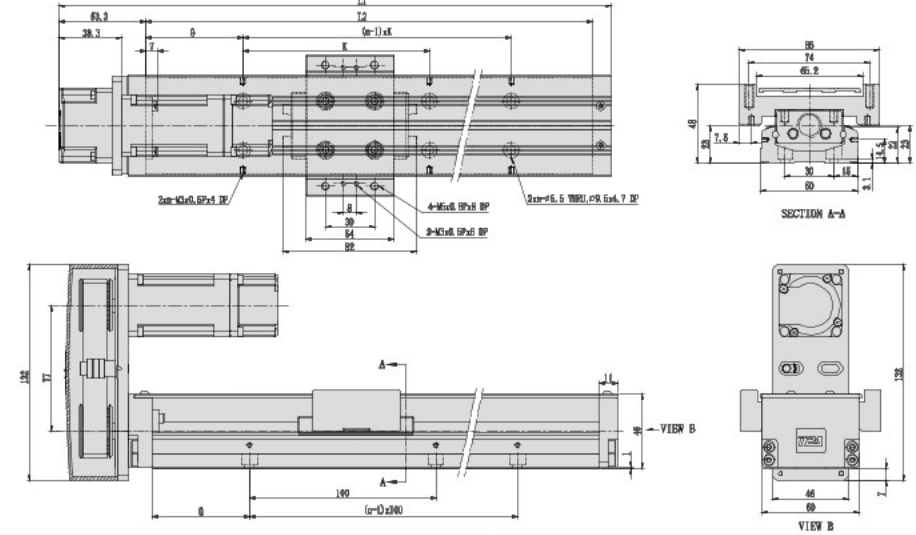

轨道长度 L2 Track length	全长(L1) Full length	最大行程(mm) Maximum travel		G(mm)	K(mm)	n	m	重量(kg) Weight	
		滑座 A1 Slide carriage	滑座 A2 Slide carriage					滑座 A1 Slide carriage	滑座 A2 Slide carriage
150	214.3	60	-	25	100	2	2	1.6	-
200	264.3	110	-	50	100	2	2	2	-
300	364.3	210	135	50	200	3	2	2.6	2.9
400	464.3	310	235	50	100	4	4	3.2	3.5
500	564.3	410	335	50	200	5	3	3.8	4.1
600	664.3	510	435	50	100	6	6	4.5	4.9

ML KNR-60 电机外置左侧(含护盖) KNR-60 Motor external left side (Cover included)

单位:Unit: mm

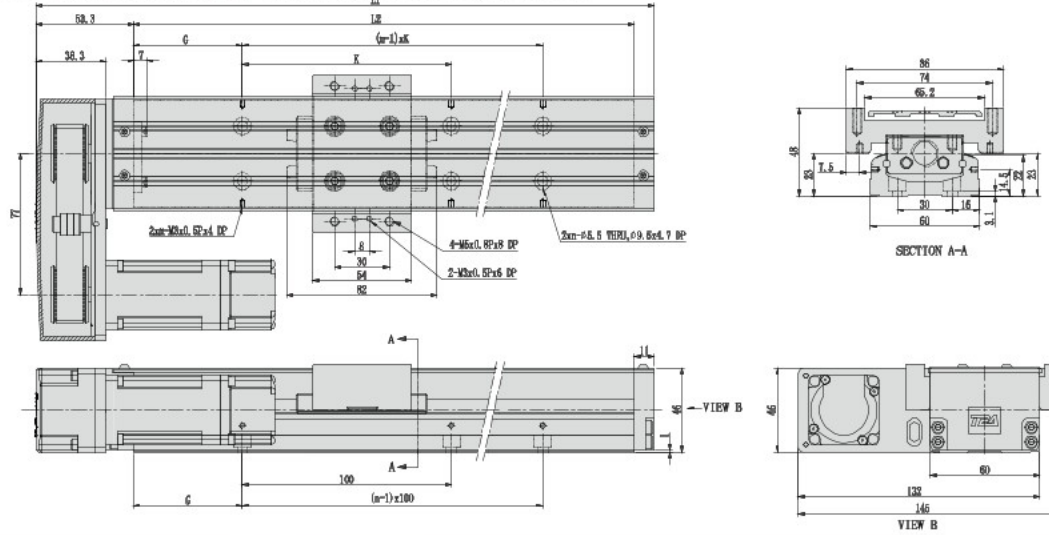

轨道长度 L2 Track length	全长(L1) Full length	最大行程(mm) Maximum travel		G(mm)	K(mm)	n	m	重量(kg) Weight	
		滑座 A1 Slide carriage	滑座 A2 Slide carriage					滑座 A1 Slide carriage	滑座 A2 Slide carriage
150	214.3	60	-	25	100	2	2	1.6	-
200	264.3	110	-	50	100	2	2	2	-
300	364.3	210	135	50	200	3	2	2.6	2.9
400	464.3	310	235	50	100	4	4	3.2	3.5
500	564.3	410	335	50	200	5	3	3.8	4.1
600	664.3	510	435	50	100	6	6	4.5	4.9

MP KNR-60 电机外置下方(含护盖) KNR-60 Motor external under below (Cover included)

单位:Unit: mm

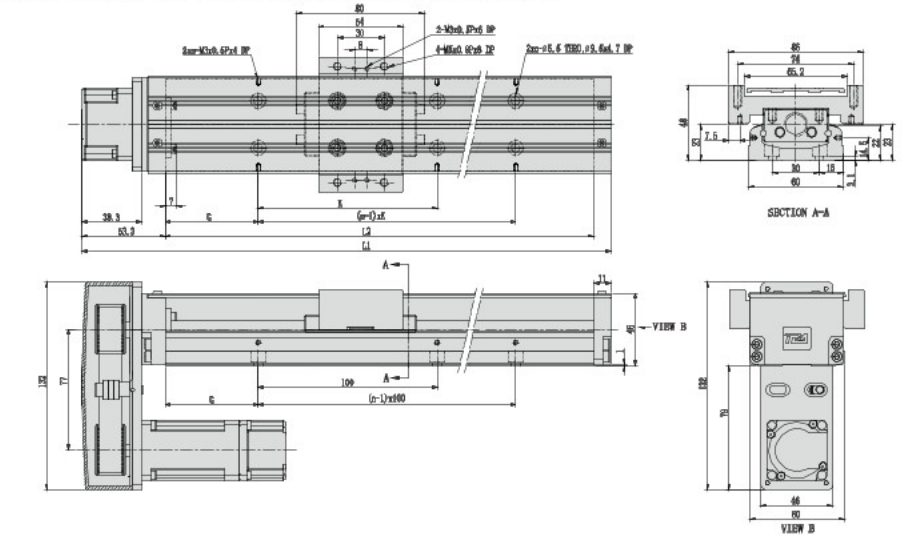

轨道长度 L2 Track length	全长(L1) Full length	最大行程(mm) Maximum travel		G(mm)	K(mm)	n	m	重量(kg) Weight	
		滑座 A1 Slide carriage	滑座 A2 Slide carriage					滑座 A1 Slide carriage	滑座 A2 Slide carriage
150	214.3	60	-	25	100	2	2	1.6	-
200	264.3	110	-	50	100	2	2	2	-
300	364.3	210	135	50	200	3	2	2.6	2.9
400	464.3	310	235	50	100	4	4	3.2	3.5
500	564.3	410	335	50	200	5	3	3.8	4.1
600	664.3	510	435	50	100	6	6	4.5	4.9

HNR
HCR
HNB
HCB
HNT
XYZ
ONB
OCB
GCR
GCB
GCBS
GCRS
ESR
EMR
EHR
KSR
LNP
DDR

参考资料
Reference
data

KFR 外形尺寸(含伸缩护套)
KFR Overall dimensions (Guideway Cover)

M KFR-60 电机外置直连(含伸缩护套) KFR-60 Motor external direct connection (Guideway Cover) 单位:Unit: mm

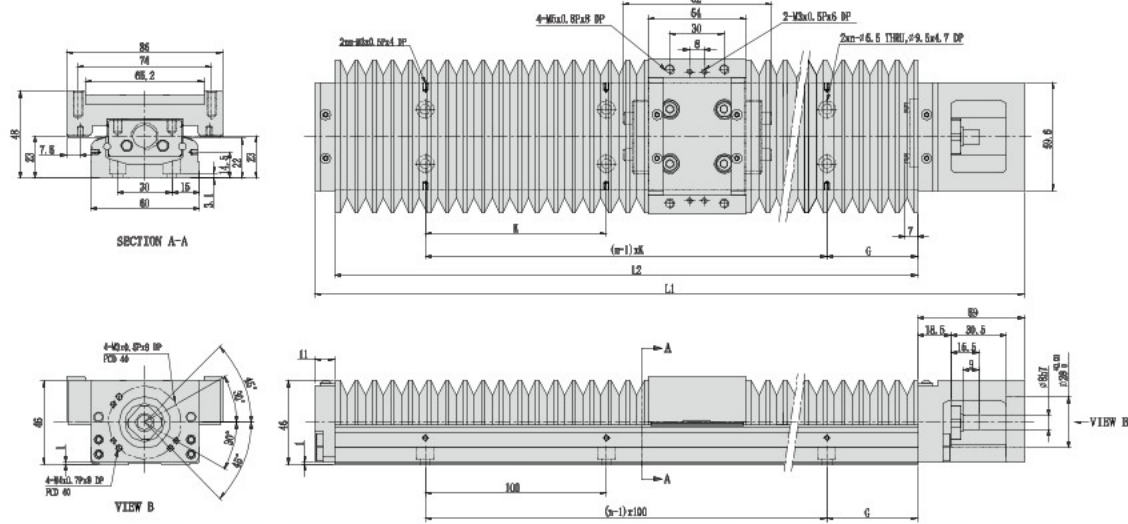

轨道长度 L2 Track length	全长(L1) Full length	行程(mm) Stroke	护套伸缩量(mm) Telescopic amount of sheath		G(mm)	K(mm)	n	重量(kg) Weight	重量(kg) Weight
			最小伸缩量(mm) Minimum expansion	最大伸缩量(mm) Maximum expansion					
150	220	50	13	66	25	100	2	2	1.7
200	270	90	19.5	110	50	100	2	2	2.1
300	370	160	35	195	50	200	3	2	2.7
400	470	230	49.5	278	50	100	4	4	3.3
500	570	310	59.5	370	50	200	5	3	3.9
600	670	380	75	455	50	100	6	6	4.6

KFR 外形尺寸(含伸缩护套)
KFR Overall dimensions (Guideway Cover)

MR KFR-60 电机外置右侧(含伸缩护套) KFR-60 Motor external right side (Guideway Cover) 单位:Unit: mm

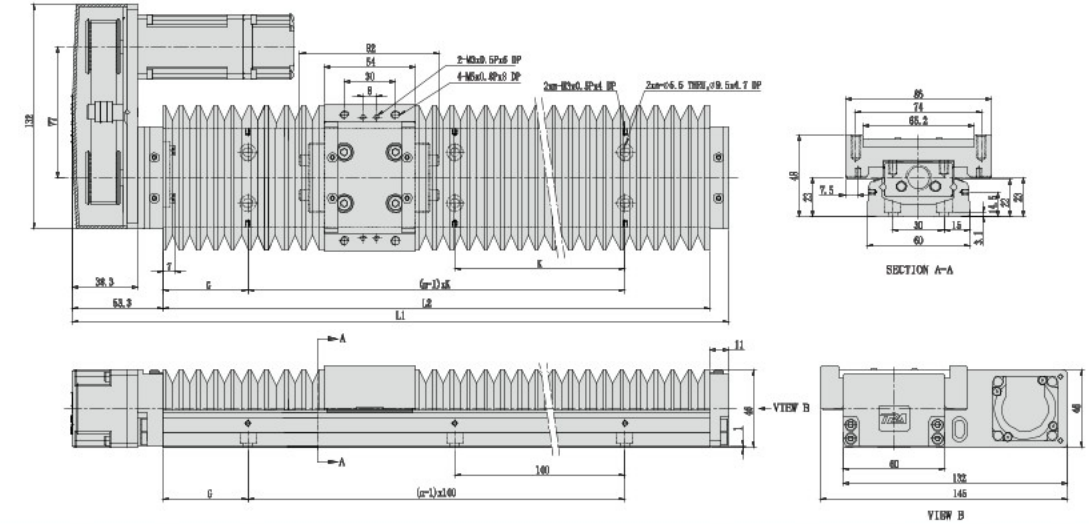

轨道长度 L2 Track length	全长(L1) Full length	行程(mm) Stroke	护套伸缩量(mm) Telescopic amount of sheath		G(mm)	K(mm)	n	重量(kg) Weight	重量(kg) Weight
			最小伸缩量(mm) Minimum expansion	最大伸缩量(mm) Maximum expansion					
150	214.3	50	13	66	25	100	2	2	1.6
200	264.3	90	19.5	110	50	100	2	2	2
300	364.3	160	35	195	50	200	3	2	2.6
400	464.3	230	49.5	278	50	100	4	4	3.2
500	564.3	310	59.5	370	50	200	5	3	3.8
600	664.3	380	75	455	50	100	6	6	4.5

H0 KFR-60-H0(含伸缩护套) KFR-60-H0 (Guideway Cover) 单位:Unit: mm

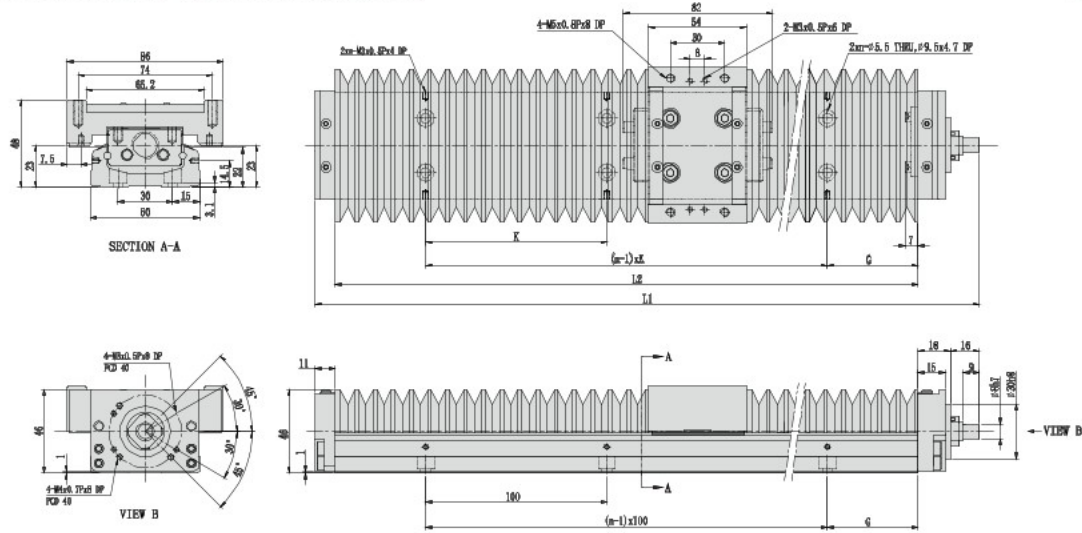

轨道长度 L2 Track length	全长(L1) Full length	行程(mm) Stroke	护套伸缩量(mm) Telescopic amount of sheath		G(mm)	K(mm)	n	重量(kg) Weight	重量(kg) Weight
			最小伸缩量(mm) Minimum expansion	最大伸缩量(mm) Maximum expansion					
150	220	50	13	66	25	100	2	2	1.6
200	270	90	19.5	110	50	100	2	2	2
300	370	160	35	195	50	200	3	2	2.6
400	470	230	49.5	278	50	100	4	4	3.2
500	570	310	59.5	370	50	200	5	3	3.8
600	670	380	75	455	50	100	6	6	4.5

ML KFR-60 电机外置左侧(含伸缩护套) KFR-60 Motor external left side (Guideway Cover) 单位:Unit: mm

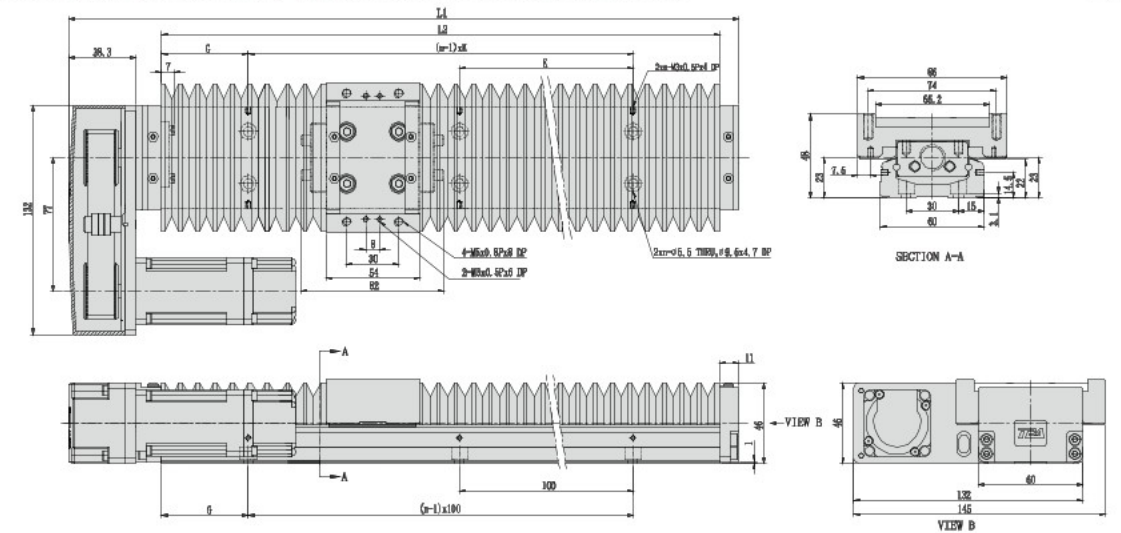

轨道长度 L2 Track length	全长(L1) Full length	行程(mm) Stroke	护套伸缩量(mm) Telescopic amount of sheath		G(mm)	K(mm)	n	重量(kg) Weight	重量(kg) Weight
			最小伸缩量(mm) Minimum expansion	最大伸缩量(mm) Maximum expansion					
150	214.3	50	13	66	25	100	2	2	1.6
200	264.3	90	19.5	110	50	100	2	2	2
300	364.3	160	35	195	50	200	3	2	2.6
400	464.3	230	49.5	278	50	100	4	4	3.2
500	564.3	310	59.5	370	50	200	5	1.5	3.8
600	664.3	380	75	455	50	100	6	6	4.5

HNR
HCR
HNB
HCB
HNT
XYZ
ONB
OCB
GCR
GCB
GCBS
GCRS
ESR
EMR
EHR
KSR
LNP
DDR

参考资料
Reference data

KFR 外形尺寸(含伸缩护套)
KFR Overall dimensions (Guideway Cover)

MU KFR-60 电机外置上方(含伸缩护套) KFR-60 Motor external above (Guideway Cover)

单位:Unit: mm

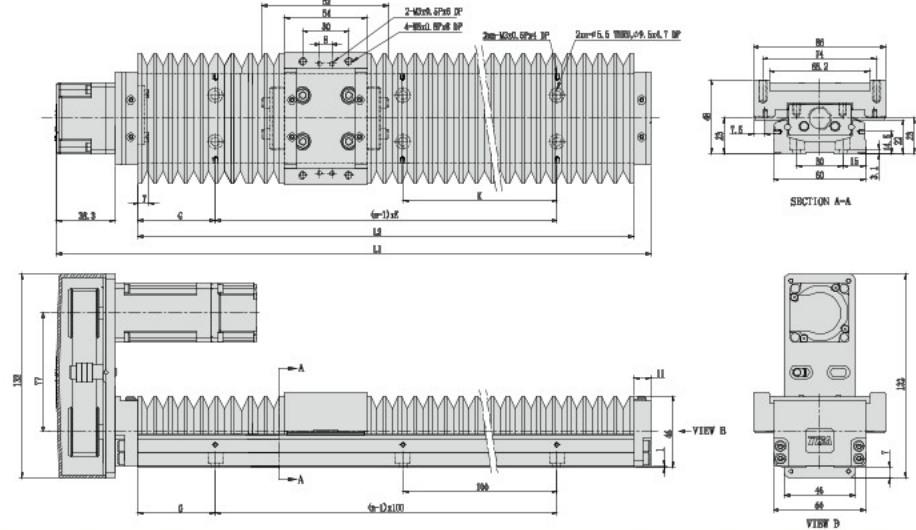

轨道长度 L2 Track length	全长(L1) Full length	行程(mm) Stroke	护套伸缩量(mm) Telescopic amount of sheath		G(mm)	K(mm)	n	重量(kg) Weight	重量(kg) Weight
			最小伸缩量(mm) Minimum expansion	最大伸缩量(mm) Maximum expansion					
150	214.3	50	13	66	25	100	2	2	1.6
200	264.3	90	19.5	110	50	100	2	2	2
300	364.3	160	35	195	50	200	3	2	2.6
400	464.3	230	49.5	278	50	100	4	4	3.2
500	564.3	310	59.5	370	50	200	5	3	3.8
600	664.3	380	75	455	50	100	6	6	4.5

MP KFR-60 电机外置下方(含伸缩护套) KFR-60 Motor external under below (Guideway Cover)

单位:Unit: mm

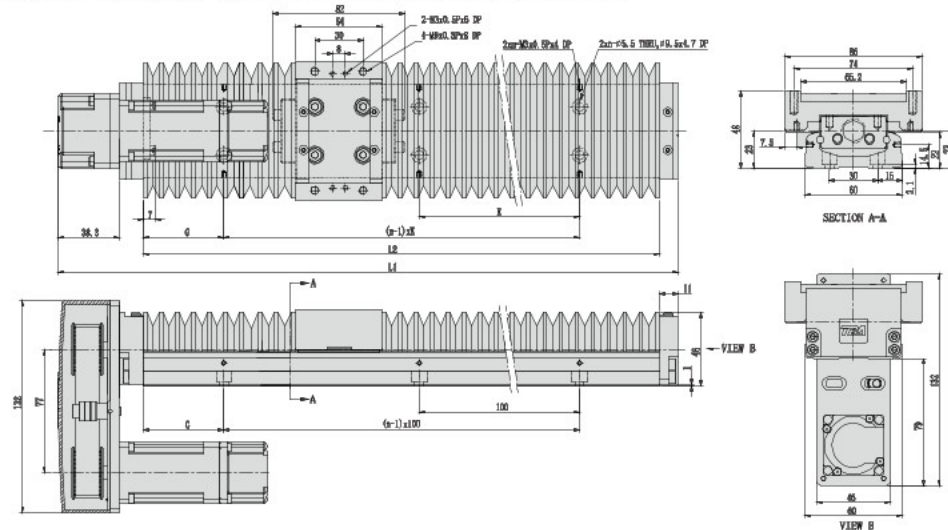

轨道长度 L2 Track length	全长(L1) Full length	行程(mm) Stroke	护套伸缩量(mm) Telescopic amount of sheath		G(mm)	K(mm)	n	重量(kg) Weight	重量(kg) Weight
			最小伸缩量(mm) Minimum expansion	最大伸缩量(mm) Maximum expansion					
150	214.3	50	13	66	25	100	2	2	1.6
200	264.3	90	19.5	110	50	100	2	2	2
300	364.3	160	35	195	50	200	3	2	2.6
400	464.3	230	49.5	278	50	100	4	4	3.2
500	564.3	310	59.5	370	50	200	5	3	3.8
600	664.3	380	75	455	50	100	6	6	4.5

电机座与电机连接法兰
Motor seat and motor connecting flange

60 电机座F0 Motor seat F0

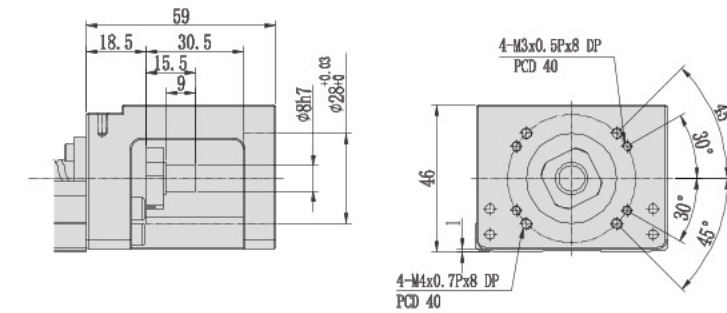

电机座H0 Motor seat H0

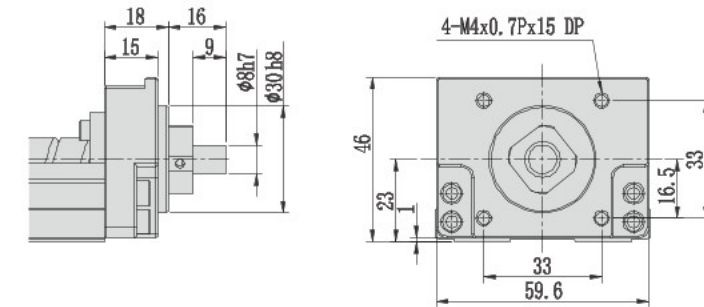

60 电机座H1 Motor seat H1

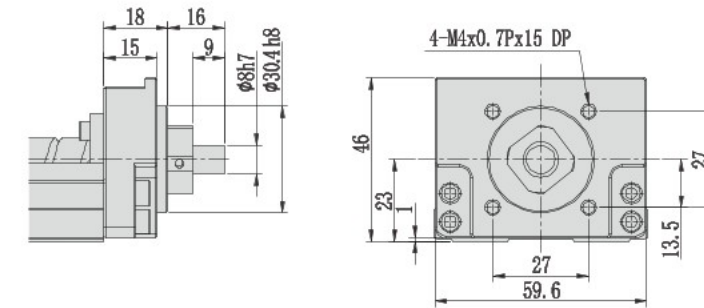

电机连接法兰F1(台达/安川/汇川/三菱/富士 100W) Connecting flange F1 of motor (Delta/Yaskawa/Inovance/Mitsubishi/Fuji 100W)

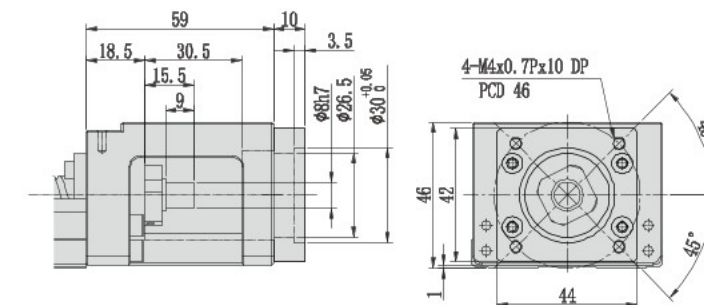

- HNR
- HCR
- HNB
- HCB
- HNT
- XYZ
- ONB
- OCB
- GCR
- GCB
- GCBS
- GCRS
- ESR
- EMR
- EHR
- KSR**
- LNP
- DDR

参考资料
Reference data

电机座与电机连接法兰
Motor seat and motor connecting flange

60 电机连接法兰F2(松下 50W/100W) Connecting flange F2 of motor (Panasonic 50W/100W)

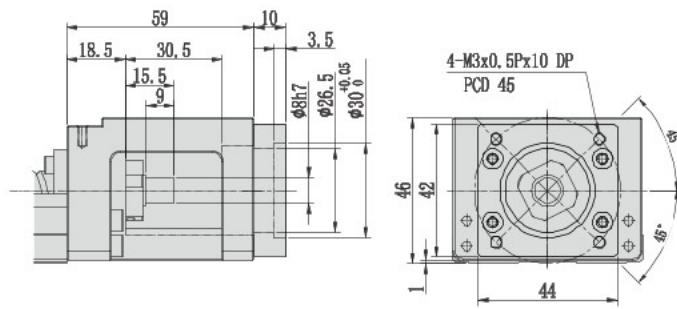

电机连接法兰F3(60步进) Connecting flange F3 of motor (60 Stepper)

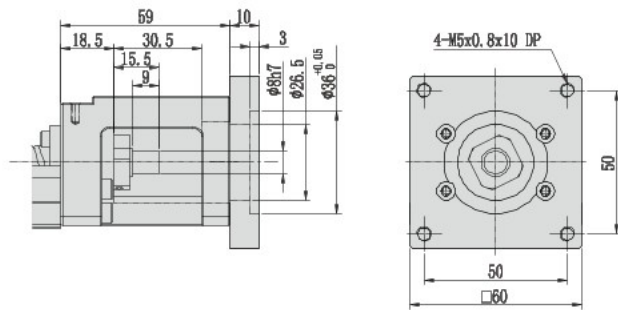

60 电机连接法兰F4(57步进) Connecting flange F4 of motor (57 Stepper)

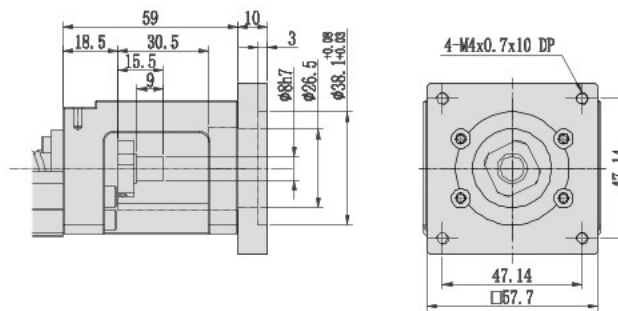

电机连接法兰F5(42步进) Connecting flange F5 of motor (42 Stepper)

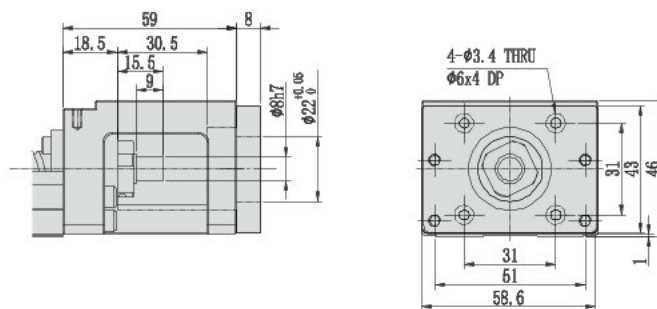

电机座与电机连接法兰
Motor seat and motor connecting flange

60 电机连接法兰F6(松下 200W/400W) Connecting flange F6 of motor (Panasonic 200W/400W)

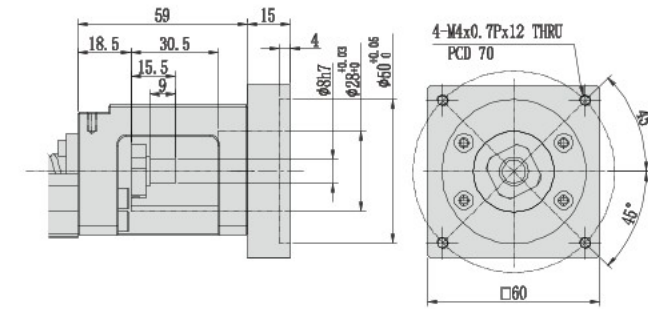

电机连接法兰F7(台达/安川/汇川/三菱/富士 200W/400W) Connecting flange F7 of motor (Delta/Yaskawa/Inovance/Mitsubishi/Fuji 200W/400W)

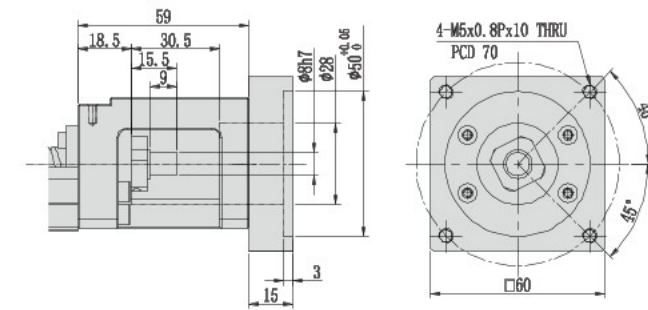

- HNR
- HCR
- HNB
- HCB
- HNT
- XYZ
- ONB
- OCB
- GCR
- GCB
- GCBS
- GCRS
- ESR
- EMR
- EHR
- KSR**
- LNP
- DDR
- 参考资料
Reference data



重复精度
Repeat Accuracy
±0.005
mm

此图仅供参考, 出货规格详见尺寸图面
This picture for reference only, specs details according with the drawing.

最大行程
Max Stroke 816.5mm

最高速度
Max Speed 1600mm/sec

滚珠螺杆
Ball Screw Ø 16 mm

型号表达方式 Ordering method

TPA-KSR-8610CK-340A1-M-F0S2-N3-D-F

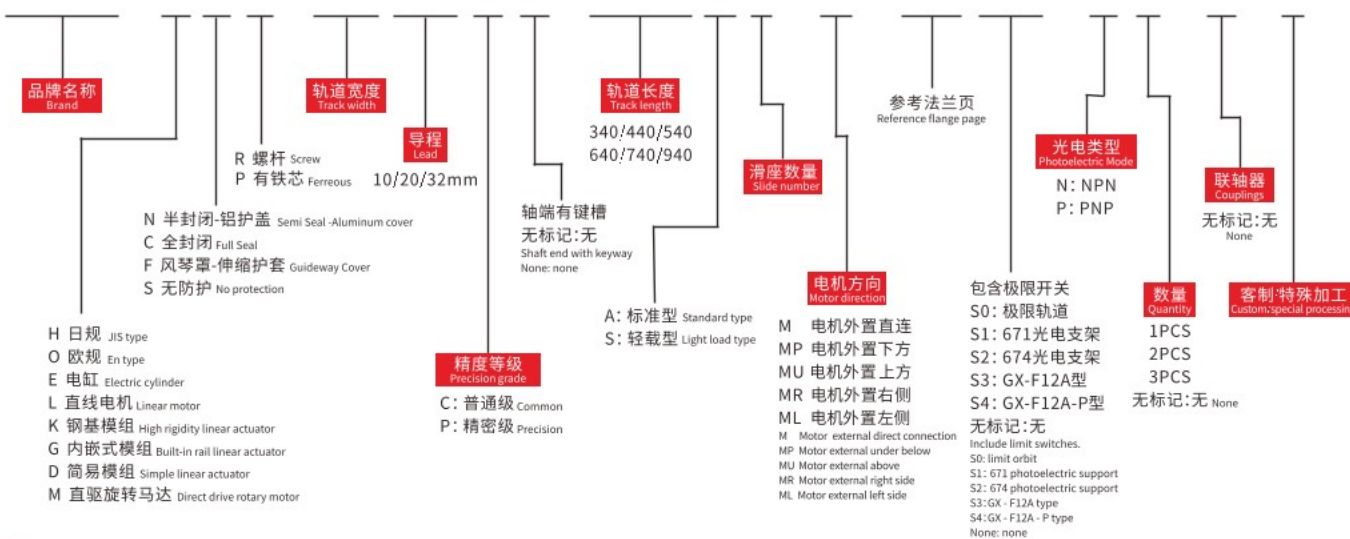

负载规格 Load specification

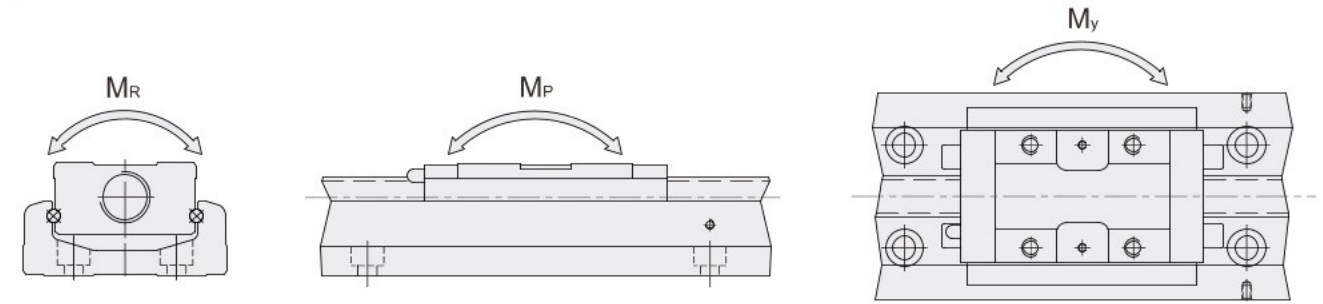

技术参数 Technical parameter

型号 Model	滚珠螺杆 Ballscrew				线性滑轨 Linear slider rail																
	公称外径 (mm)	导程 (mm)	基本动态额定负荷 (N)	基本静态额定负荷 (N)	基本动态额定负荷 (N)		基本静态额定负荷 (N)		容许静力矩 Allowable static moment												
					滑座 A Slide carriage	滑座 S Slide carriage	滑座 A Slide carriage	滑座 S Slide carriage	俯仰 M _P (N·m)			偏扭 M _Y (N·m)			滚动 M _R (N·m)						
KSR 8610	精密级 General grade	15	10	7144 6429	12642 11387	31458	21051	50764	29475	622	3050	228	1309	622	3050	228	1309	1507	3014	847	1694
KSR 8620	精密级 General grade	15	20	4645 4175	7655 6889	31458	21051	50764	29475	622	3050	228	1309	622	3050	228	1309	1507	3014	847	1694
KSR 8632	精密级 General grade	16	32	3488 3140	6075 5468	31458	21051	50764	29475	622	3050	228	1309	622	3050	228	1309	1507	3014	847	1694

精度等级 Precision grade

型号 Model	轨道长度 Track length	定位重现性 Positioning reproducibility		定位精度 Positioning accuracy		行走平行度 Walking parallelism		最大启动扭力 (N·cm) Maximum starting torque	
		精密级 Precise grade	一般级 General grade	精密级 Precise grade	一般级 General grade	精密级 Precise grade	一般级 General grade	精密级 Precise grade	一般级 General grade
		KSR 86	340	±0.003	±0.005	0.025	-	0.015	-
440									
540									
640									
KSR 86	740	±0.003	±0.005	0.030	-	0.020	-	17	10
KSR 86	940	±0.003	±0.005	0.040	-	0.030	-	25	10

最大速度 Maximum speed

型号 Model	滚珠螺杆导程 (mm) Ballscrew lead	轨道长度 L2 (mm) Track length	速度 (mm/sec) Speed	
			精密级 Precise grade	一般级 General grade
KSR 86	10	340	740	520
		440	740	520
		540	740	520
		640	740	520
		740	740	520
		940	610	430
	20	340	1480	1050
		440	1480	1050
		540	1480	1050
		640	1480	1050
		740	1480	1050
		940	1220	870
32	340	-	1600	
	440	-	1600	
	540	-	1600	
	640	-	1600	
	740	-	1600	
	940	-	1320	

KSR 外形尺寸(不含护盖)
KSR Overall dimensions(without cover)

M KSR-86 电机外置直连(不含护盖) KSR-86 Motor external direct connection (without cover) 单位:Unit: mm

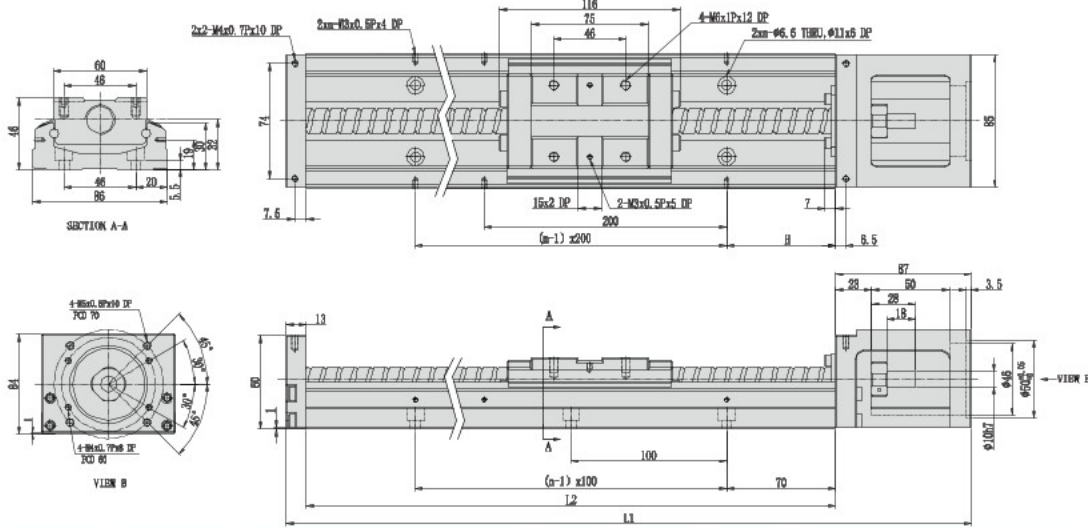

轨道长度 L2 Track length	全长(L1) Full length	最大行程(mm) Maximum travel		H(mm)	n	m	重量(kg) Weight	
		滑座 A1 Slide carriage	滑座 A2 Slide carriage				滑座 A1 Slide carriage	滑座 A2 Slide carriage
340	440	210	100	70	3	2	5.7	6.5
440	540	310	200	20	4	3	6.9	7.7
540	640	410	300	70	4	3	8	8.8
640	740	510	400	20	7	4	9.2	10
740	840	610	500	70	7	4	10.4	11.2
940	1040	810	700	70	9	5	11.6	12.4

KSR 外形尺寸(不含护盖)
KSR Overall dimensions(without cover)

MR KSR-86 电机外置右侧(不含护盖) KSR-86 Motor external right side (without cover) 单位:Unit: mm

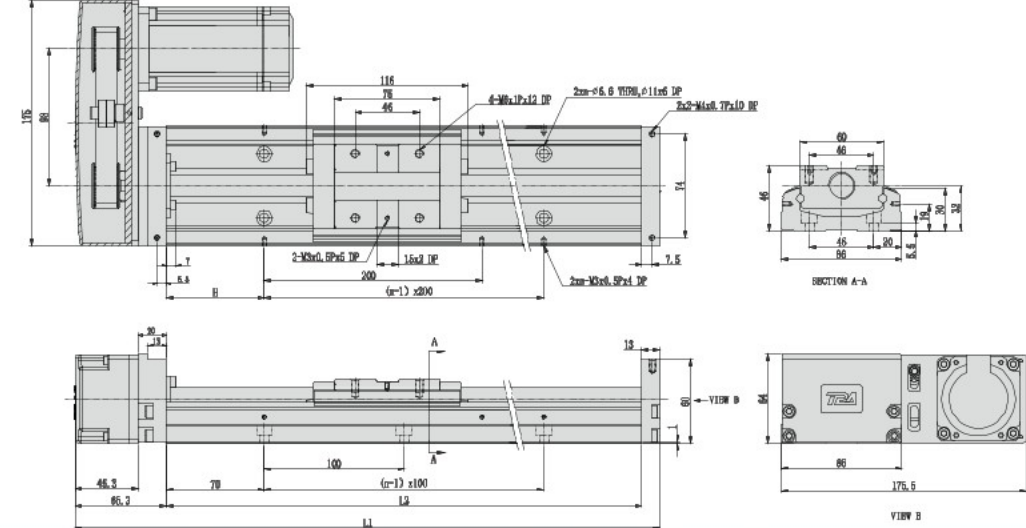

轨道长度 L2 Track length	全长(L1) Full length	最大行程(mm) Maximum travel		H(mm)	n	m	重量(kg) Weight	
		滑座 A1 Slide carriage	滑座 A2 Slide carriage				滑座 A1 Slide carriage	滑座 A2 Slide carriage
340	418.3	210	100	70	3	2	5.6	6.4
440	518.3	310	200	20	4	3	6.8	7.6
540	618.3	410	300	70	5	3	7.9	8.7
640	718.3	510	400	20	6	4	9.1	9.9
740	818.3	610	500	70	7	4	10.3	11.1
940	1018.3	810	700	70	9	5	11.5	12.3

H0 KSR-86-H0(不含护盖) KSR-86-H0 (without cover) 单位:Unit: mm

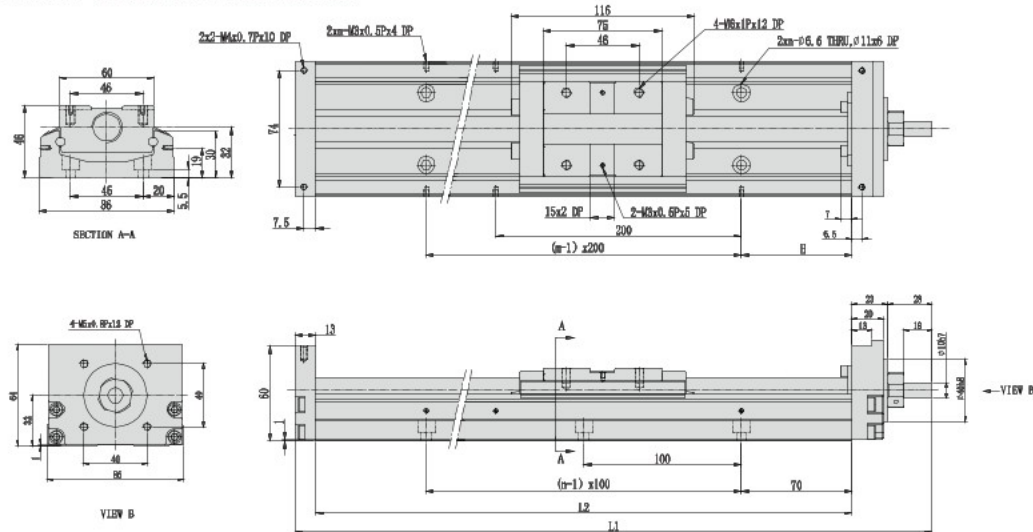

轨道长度 L2 Track length	全长(L1) Full length	最大行程(mm) Maximum travel		H(mm)	n	m	重量(kg) Weight	
		滑座 A1 Slide carriage	滑座 A2 Slide carriage				滑座 A1 Slide carriage	滑座 A2 Slide carriage
340	404	210	100	70	3	2	5.6	6.4
440	504	310	200	20	4	3	6.8	7.6
540	604	410	300	70	5	3	7.9	8.7
640	704	510	400	20	6	4	9.1	9.9
740	704	610	500	70	7	4	10.3	11.1
940	1004	810	700	70	9	5	11.5	12.3

ML KSR-86 电机外置左侧(不含护盖) KSR-86 Motor external left side (without cover) 单位:Unit: mm

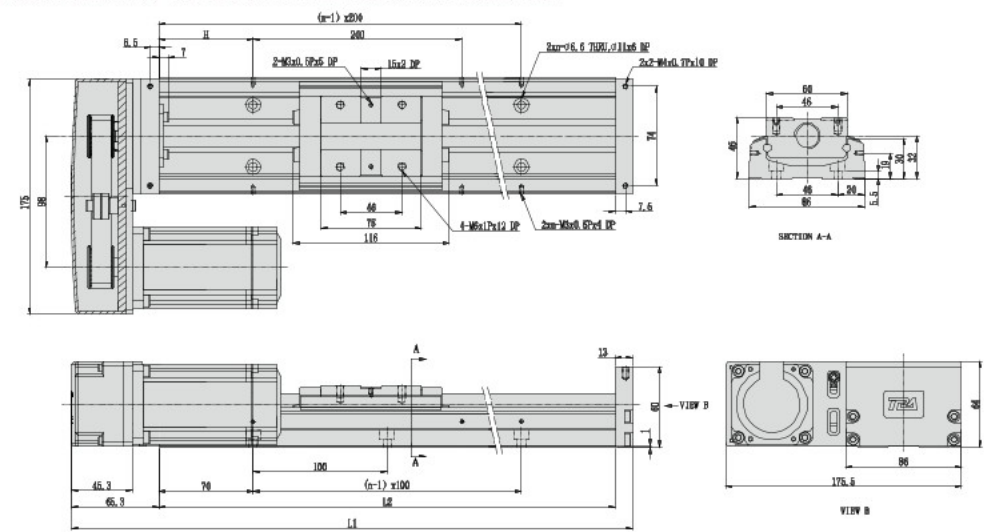

轨道长度 L2 Track length	全长(L1) Full length	最大行程(mm) Maximum travel		H(mm)	n	m	重量(kg) Weight	
		滑座 A1 Slide carriage	滑座 A2 Slide carriage				滑座 A1 Slide carriage	滑座 A2 Slide carriage
340	418.3	210	100	70	3	2	5.6	6.4
440	518.3	310	200	20	4	3	6.8	7.6
540	618.3	410	300	70	5	3	7.9	8.7
640	718.3	510	400	20	6	4	9.1	9.9
740	818.3	610	500	70	7	4	10.3	11.1
940	1018.3	810	700	70	9	5	11.5	12.3

HNR
HCR
HNB
HCB
HNT
XYZ
ONB
OCB
GCR
GCB
GCBS
GCRS
ESR
EMR
EHR
KSR
LNP
DDR

参考资料
Reference data

KSR 外形尺寸(不含护盖)
KSR Overall dimensions(without cover)

MU KSR-86 电机外置上方(不含护盖) KSR-86 Motor external above (without cover) 单位:Unit: mm

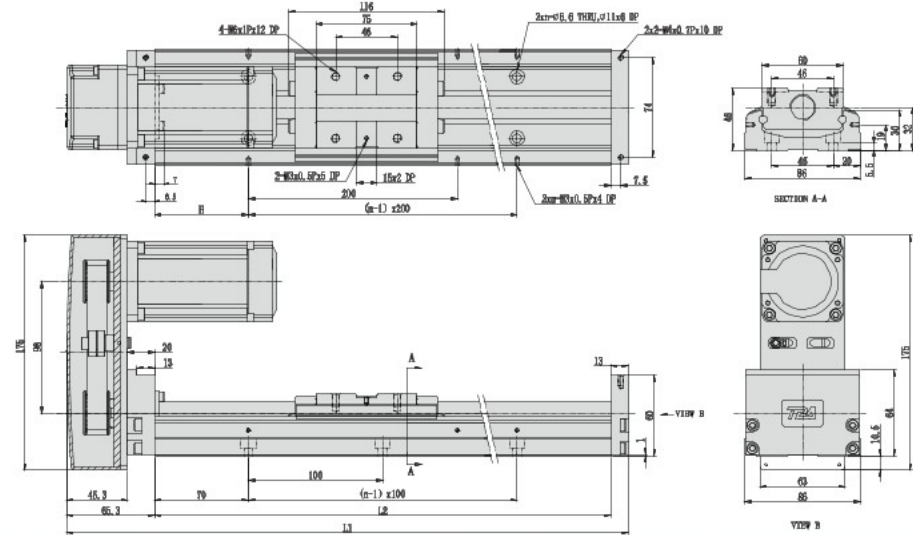

轨道长度 L2 Track length	全长(L1) Full length	最大行程(mm) Maximum travel		H(mm)	n	m	重量(kg) Weight	
		滑座 A1 Slide carriage	滑座 A2 Slide carriage				滑座 A1 Slide carriage	滑座 A2 Slide carriage
340	418.3	210	100	70	3	2	5.6	6.4
440	518.3	310	200	20	4	3	6.8	7.6
540	618.3	410	300	70	5	3	7.9	8.7
640	718.3	510	400	20	6	4	9.1	9.9
740	818.3	610	500	70	7	4	10.3	11.1
940	1018.3	810	700	70	9	5	11.5	12.3

KNR 外形尺寸(含护盖)
KNR Overall dimensions(Cover included)

M KNR-86 电机外置直连(含护盖) KNR-86 Motor external direct connection (Cover included) 单位:Unit: mm

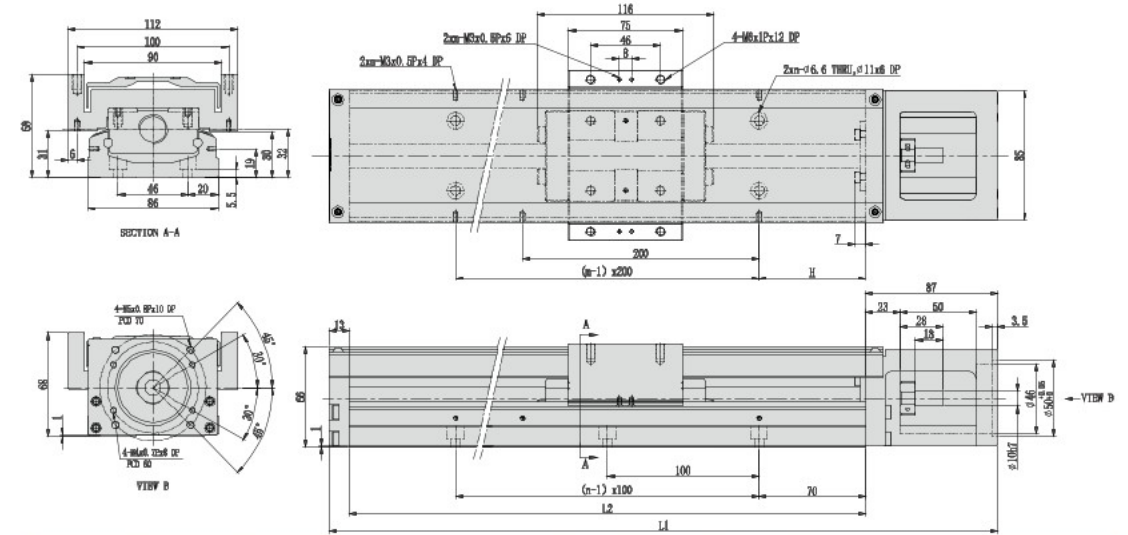

轨道长度 L2 Track length	全长(L1) Full length	最大行程(mm) Maximum travel		H(mm)	n	m	重量(kg) Weight	
		滑座 A1 Slide carriage	滑座 A2 Slide carriage				滑座 A1 Slide carriage	滑座 A2 Slide carriage
340	440	210	100	70	3	2	6.5	7.3
440	540	310	200	20	4	3	7.8	8.6
540	640	410	300	70	5	3	9	9.8
640	740	510	400	20	6	4	10.3	11.3
740	840	610	500	70	7	4	11.6	12.4
940	1040	810	700	70	9	5	13	13.8

MP KSR-86 电机外置下方(不含护盖) KSR-86 Motor external under below (without cover) 单位:Unit: mm

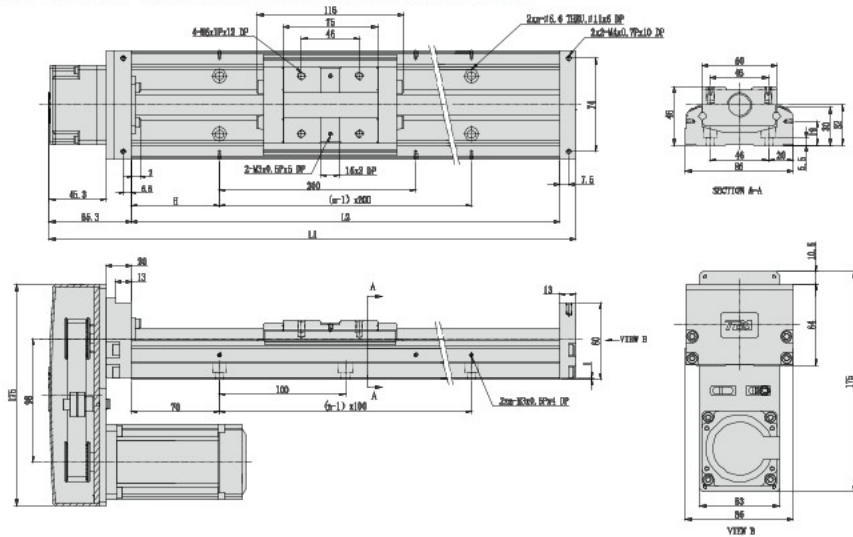

轨道长度 L2 Track length	全长(L1) Full length	最大行程(mm) Maximum travel		H(mm)	n	m	重量(kg) Weight	
		滑座 A1 Slide carriage	滑座 A2 Slide carriage				滑座 A1 Slide carriage	滑座 A2 Slide carriage
340	418.3	210	100	70	3	2	5.6	6.4
440	518.3	310	200	20	4	3	6.8	7.6
540	618.3	410	300	70	5	3	7.9	8.7
640	718.3	510	400	20	6	4	9.1	9.9
740	818.3	610	500	70	7	4	10.3	11.1
940	1018.3	810	700	70	9	5	11.5	12.3

H0 KNR-86-H0(含护盖) KNR-86-H0 (including cover) 单位:Unit: mm

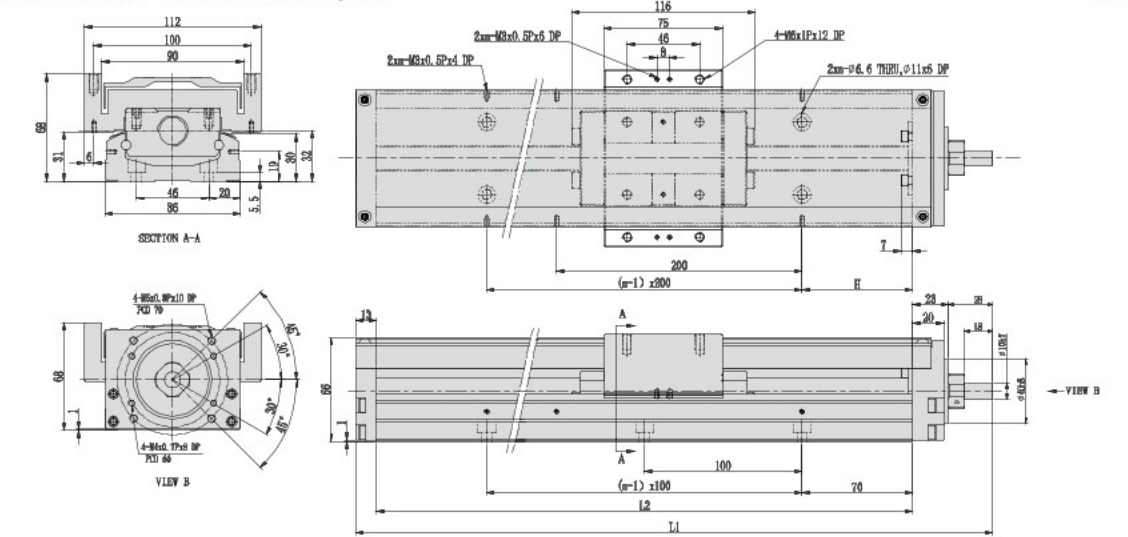

轨道长度 L2 Track length	全长(L1) Full length	最大行程(mm) Maximum travel		H(mm)	n	m	重量(kg) Weight	
		滑座 A1 Slide carriage	滑座 A2 Slide carriage				滑座 A1 Slide carriage	滑座 A2 Slide carriage
340	404	210	100	70	3	2	6.4	7.2
440	504	310	200	20	4	3	7.7	8.3
540	604	410	300	70	5	3	8.9	9.7
640	704	510	400	20	6	4	10	11.2
740	804	610	500	70	7	4	11.3	12.3
940	1004	810	700	70	9	5	12.7	13.7

HNR
HCR
HNB
HCB
HNT
XYZ
ONB
OCB
GCR
GCB
GCBS
GCRS
ESR
EMR
EHR
KSR
LNP
DDR
参考资料
Reference
data

KNR 外形尺寸(含护盖)
KNR Overall dimensions(Cover included)

MR KNR-86 电机外置右侧(含护盖) KNR-86 Motor external right side (Cover included)

单位:Unit: mm

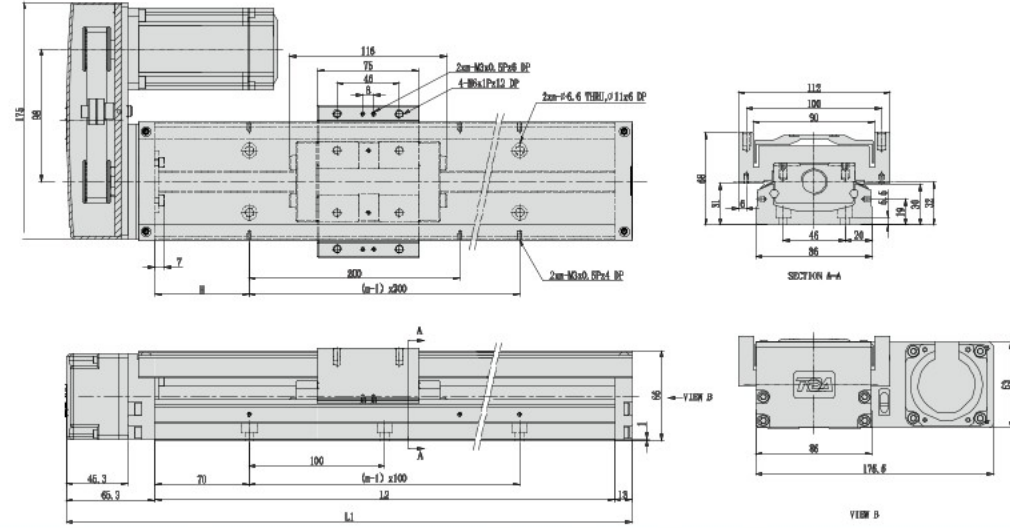

轨道长度 L2 Track length	全长(L1) Full length	最大行程(mm) Maximum travel		H(mm)	n	m	重量(kg) Weight	
		滑座 A1 Slide carriage	滑座 A2 Slide carriage				滑座 A1 Slide carriage	滑座 A2 Slide carriage
340	418.3	210	100	70	3	2	6.4	7.2
440	518.3	310	200	20	4	3	7.7	8.3
540	618.3	410	300	70	5	3	8.9	9.7
640	718.3	510	400	20	6	4	10	11.2
740	818.3	610	500	70	7	4	11.3	12.3
940	1018.3	810	700	70	9	5	12.7	13.7

KNR 外形尺寸(含护盖)
KNR Overall dimensions(Cover included)

MU KNR-86 电机外置上方(含护盖) KNR-86 Motor external above (Cover included)

单位:Unit: mm

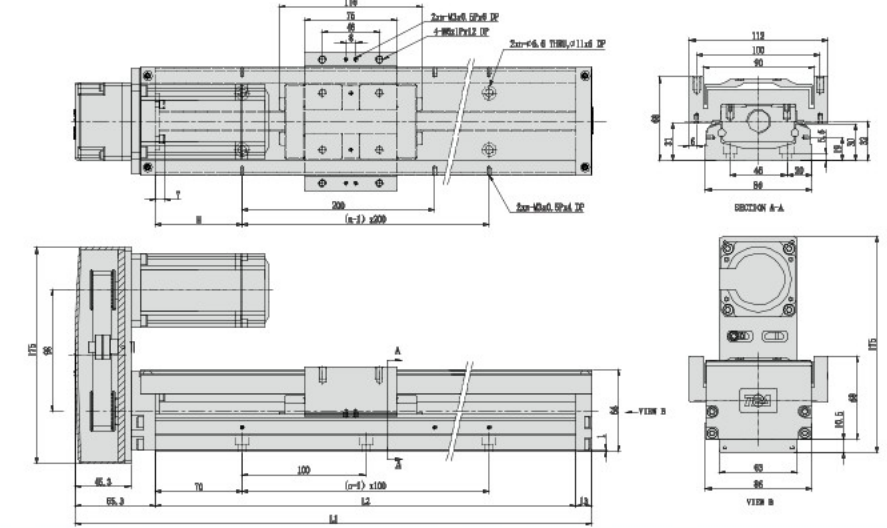

轨道长度 L2 Track length	全长(L1) Full length	最大行程(mm) Maximum travel		H(mm)	n	m	重量(kg) Weight	
		滑座 A1 Slide carriage	滑座 A2 Slide carriage				滑座 A1 Slide carriage	滑座 A2 Slide carriage
340	418.3	210	100	70	3	2	6.4	7.2
440	518.3	310	200	20	4	3	7.7	8.3
540	618.3	410	300	70	5	3	8.9	9.7
640	718.3	510	400	20	6	4	10	11.2
740	818.3	610	500	70	7	4	11.3	12.3
940	1018.3	810	700	70	9	5	12.7	13.7

ML KNR-86 电机外置左侧(含护盖) KNR-86 Motor external left side (Cover included)

单位:Unit: mm

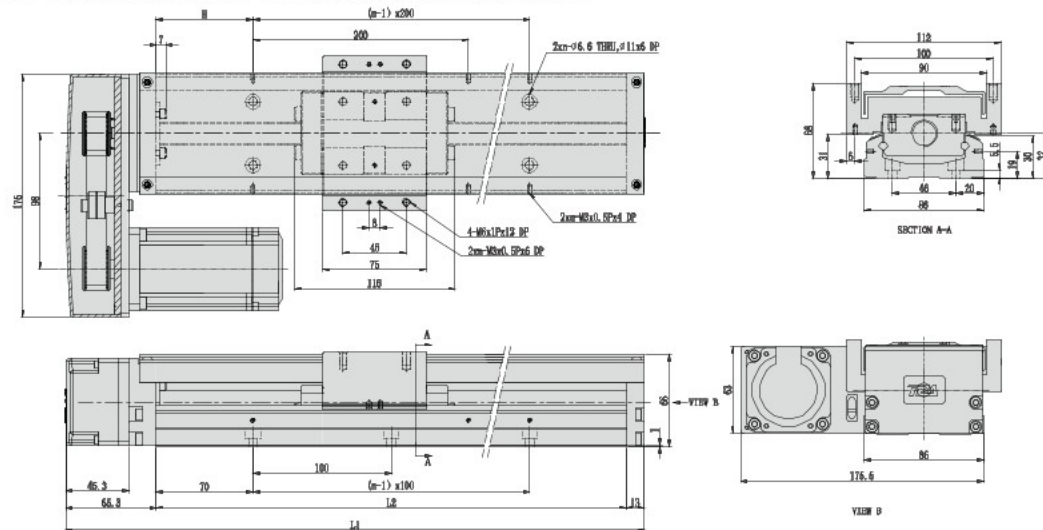

轨道长度 L2 Track length	全长(L1) Full length	最大行程(mm) Maximum travel		H(mm)	n	m	重量(kg) Weight	
		滑座 A1 Slide carriage	滑座 A2 Slide carriage				滑座 A1 Slide carriage	滑座 A2 Slide carriage
340	418.3	210	100	70	3	2	6.4	7.2
440	518.3	310	200	20	4	3	7.7	8.3
540	618.3	410	300	70	5	3	8.9	9.7
640	718.3	510	400	20	6	4	10	11.2
740	818.3	610	500	70	7	4	11.3	12.3
940	1018.3	810	700	70	9	5	12.7	13.7

MP KNR-86 电机外置下方(含护盖) KNR-86 Motor external under below (Cover included)

单位:Unit: mm

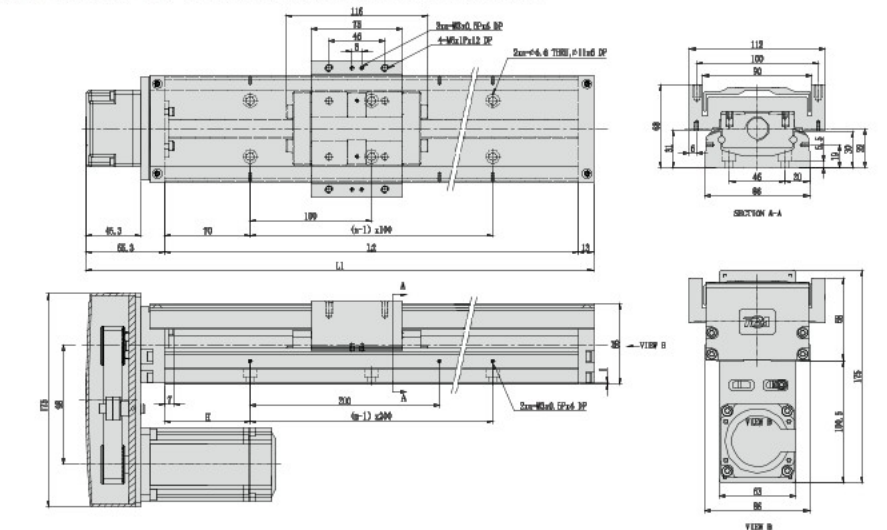

轨道长度 L2 Track length	全长(L1) Full length	最大行程(mm) Maximum travel		H(mm)	n	m	重量(kg) Weight	
		滑座 A1 Slide carriage	滑座 A2 Slide carriage				滑座 A1 Slide carriage	滑座 A2 Slide carriage
340	418.3	210	100	70	3	2	6.4	7.2
440	518.3	310	200	20	4	3	7.7	8.3
540	618.3	410	300	70	5	3	8.9	9.7
640	718.3	510	400	20	6	4	10	11.2
740	818.3	610	500	70	7	4	11.3	12.3
940	1018.3	810	700	70	9	5	12.7	13.7

HNR
HCR
HNB
HCB
HNT
XYZ
ONB
OCB
GCR
GCB
GCBS
GCRS
ESR
EMR
EHR
KSR
LNP
DDR

参考资料
Reference data

KFR 外形尺寸(含伸缩护套)
KFR Overall dimensions (Guideway Cover)

M KFR-86 电机外置直连(含伸缩护套) KFR-86 Motor external direct connection (Guideway Cover)

单位:Unit: mm

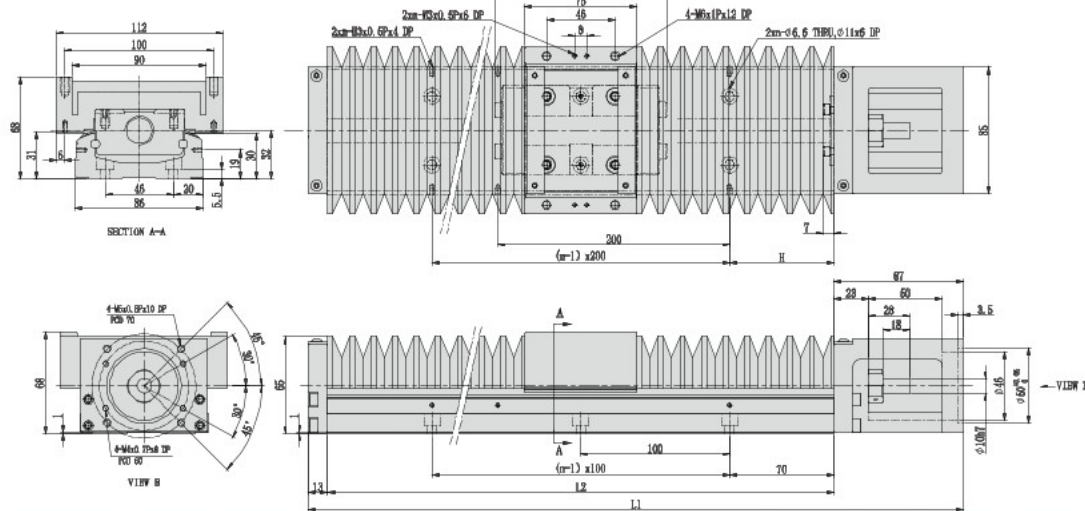

轨道长度 L2 Track length	全长(L1) Full length	行程(mm) Stroke	护套伸缩量(mm) Telescopic amount of sheath		H(mm)	n	m	重量(kg) Weight
			最小伸缩量(mm) Minimum expansion	最大伸缩量(mm) Maximum expansion				
340	440	160	38	200	70	3	2	6.5
440	540	240	49	289	20	4	3	7.8
540	640	320	59.5	378.5	70	5	3	9
640	740	390	75	463	20	6	4	10.3
740	740	460	89	549	70	7	4	11.6
940	1040	610	114	724	70	9	5	13

KFR 外形尺寸(含伸缩护套)
KFR Overall dimensions (Guideway Cover)

MR KFR-86 电机外置右侧(含伸缩护套) KFR-86 Motor external right side (Guideway Cover)

单位:Unit: mm

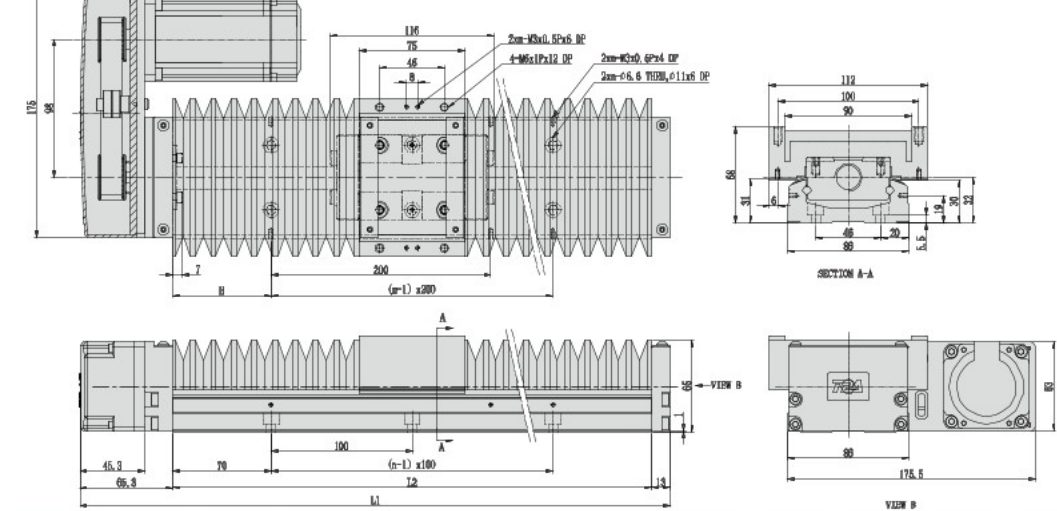

轨道长度 L2 Track length	全长(L1) Full length	行程(mm) Stroke	护套伸缩量(mm) Telescopic amount of sheath		H(mm)	n	m	重量(kg) Weight
			最小伸缩量(mm) Minimum expansion	最大伸缩量(mm) Maximum expansion				
340	418.3	160	38	200	70	3	2	6.4
440	518.3	240	49	289	20	4	3	7.7
540	618.3	320	59.5	378.5	70	5	3	8.9
640	718.3	390	75	463	20	6	4	10
740	818.3	460	89	549	70	7	4	11.3
940	1018.3	610	114	724	70	9	5	12.7

H0 KFR-86-H0(含伸缩护套) KFR-86-H0 (Guideway Cover)

单位:Unit: mm

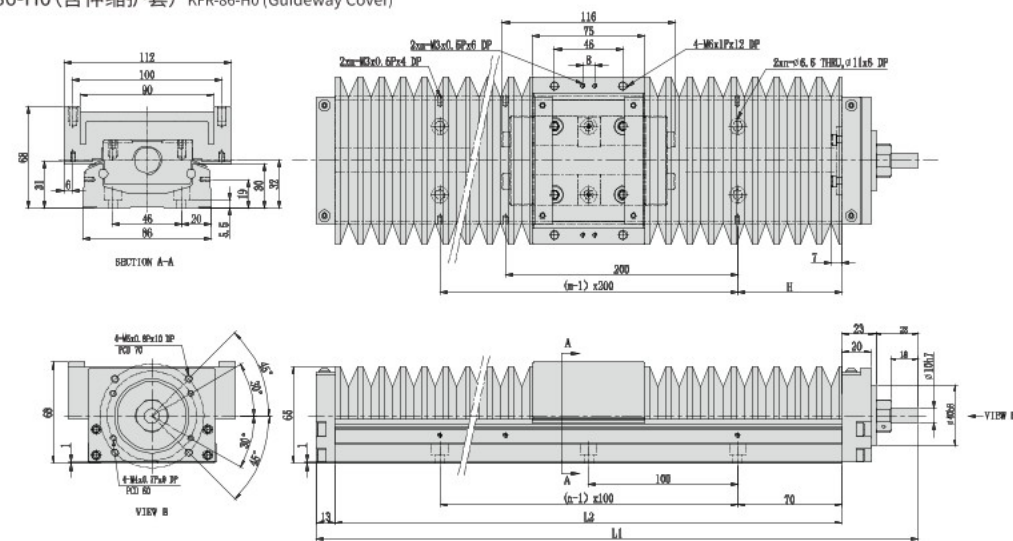

轨道长度 L2 Track length	全长(L1) Full length	行程(mm) Stroke	护套伸缩量(mm) Telescopic amount of sheath		H(mm)	n	m	重量(kg) Weight
			最小伸缩量(mm) Minimum expansion	最大伸缩量(mm) Maximum expansion				
340	404	160	38	200	70	3	2	6.4
440	504	240	49	289	20	4	3	7.7
540	604	320	59.5	378.5	70	5	3	8.9
640	704	390	75	463	20	6	4	10
740	704	460	89	549	70	7	4	11.3
940	1004	610	114	724	70	9	5	12.7

ML KFR-86 电机外置左侧(含伸缩护套) KFR-86 Motor external left side (Guideway Cover)

单位:Unit: mm

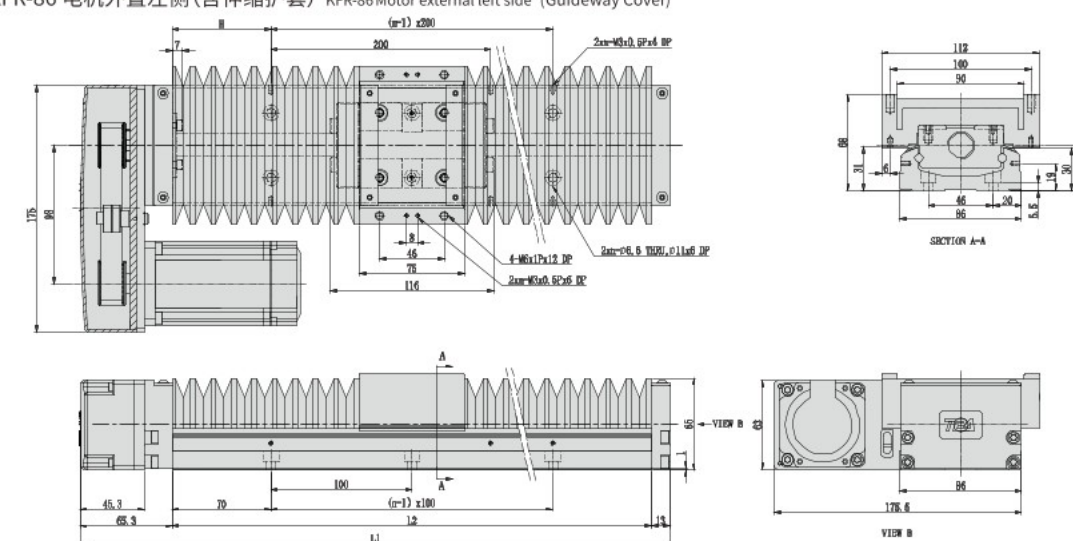

轨道长度 L2 Track length	全长(L1) Full length	行程(mm) Stroke	护套伸缩量(mm) Telescopic amount of sheath		H(mm)	n	m	重量(kg) Weight
			最小伸缩量(mm) Minimum expansion	最大伸缩量(mm) Maximum expansion				
340	418.3	160	38	200	70	3	2	6.4
440	518.3	240	49	289	20	4	3	7.7
540	618.3	320	59.5	378.5	70	5	3	8.9
640	718.3	390	75	463	20	6	4	10
740	818.3	460	89	549	70	7	4	11.3
940	1018.3	610	114	724	70	9	5	12.7

- HNR
- HCR
- HNB
- HCB
- HNT
- XYZ
- ONB
- OCB
- GCR
- GCB
- GCBS
- GCRS
- ESR
- EMR
- EHR
- KSR**
- LNP
- DDR

参考资料
Reference data

KFR 外形尺寸 (含伸缩护套)
KFR Overall dimensions (Guideway Cover)

MU KFR-86 电机外置上方 (含伸缩护套) KFR-86 Motor external above (Guideway Cover)

单位:Unit: mm

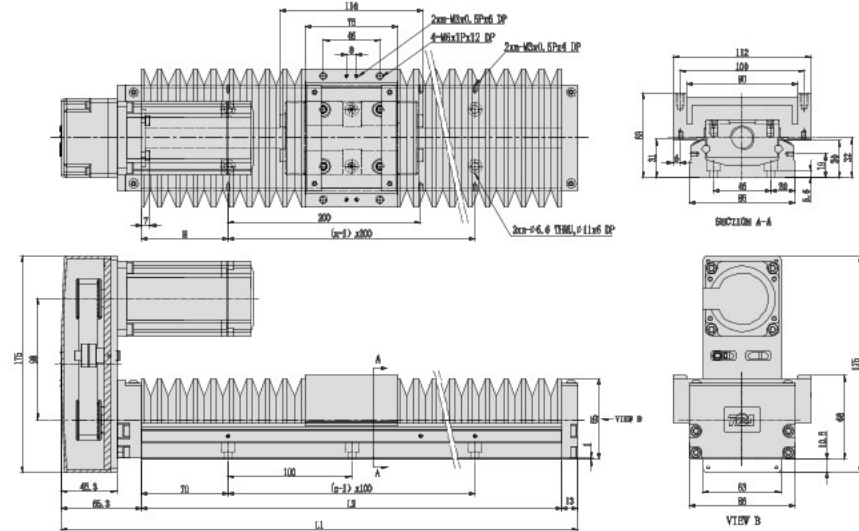

轨道长度 L2 Track length	全长(L1) Full length	行程(mm) Stroke	护套伸缩量(mm) Telescopic amount of sheath		H(mm)	n	m	重量(kg) Weight
			最小伸缩量(mm) Minimum expansion	最大伸缩量(mm) Maximum expansion				
340	418.3	160	38	200	70	3	2	6.4
440	518.3	240	49	289	20	4	3	7.7
540	618.3	320	59.5	378.5	70	5	3	8.9
640	718.3	390	75	463	20	6	4	10
740	818.3	460	89	549	70	7	4	11.3
940	1018.3	610	114	724	70	9	5	12.7

MP KFR-86 电机外置下方 (含伸缩护套) KFR-86 Motor external under below (Guideway Cover)

单位:Unit: mm

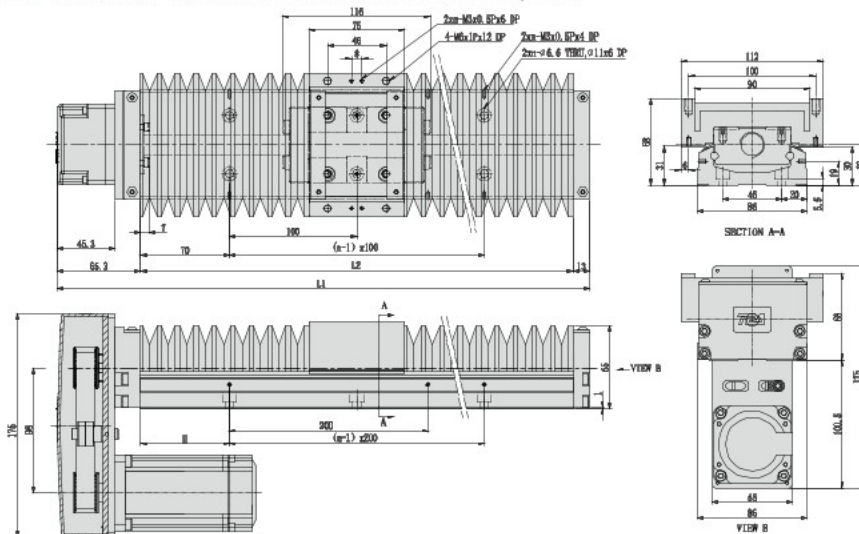

轨道长度 L2 Track length	全长(L1) Full length	行程(mm) Stroke	护套伸缩量(mm) Telescopic amount of sheath		H(mm)	n	m	重量(kg) Weight
			最小伸缩量(mm) Minimum expansion	最大伸缩量(mm) Maximum expansion				
340	418.3	160	38	200	70	3	2	6.4
440	518.3	240	49	289	20	4	3	7.7
540	618.3	320	59.5	378.5	70	5	3	8.9
640	718.3	390	75	463	20	6	4	10
740	818.3	460	89	549	70	7	4	11.3
940	1018.3	610	114	724	70	9	5	12.7

电机座与电机连接法兰
Motor seat and motor connecting flange

86 电机座F0 (台达/安川/汇川/三菱/富士 200W/400W) Motor seat F0 (Delta;Yaskawa;Inovance;Mitsubishi;Fuji 200W;400W)

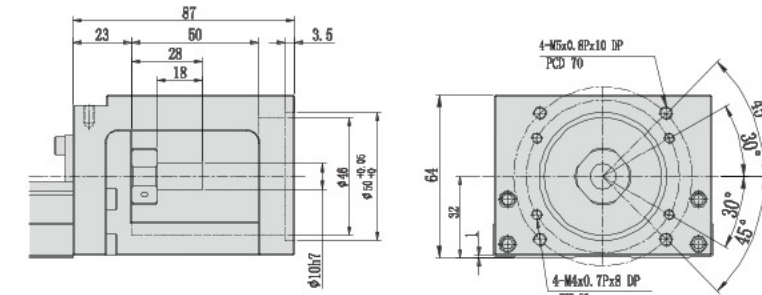

电机座H0 Motor seat H0

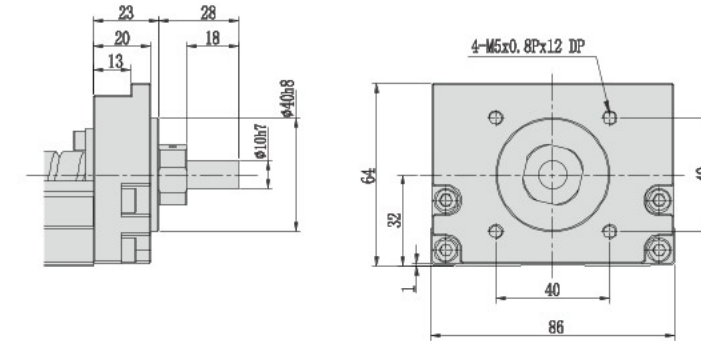

86 电机连接法兰F1 (松下 200W/400W) Connecting flange F1 of motor (Panasonic 200W/400W)

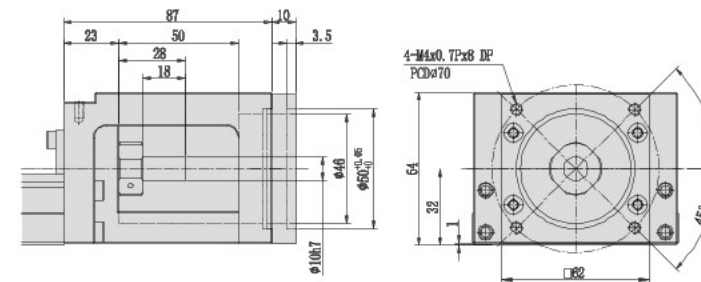

电机连接法兰F2 (台达/安川/汇川/三菱/富士 100W) Connecting flange F2 of motor (Delta;Yaskawa;Inovance;Mitsubishi;Fuji 100W)

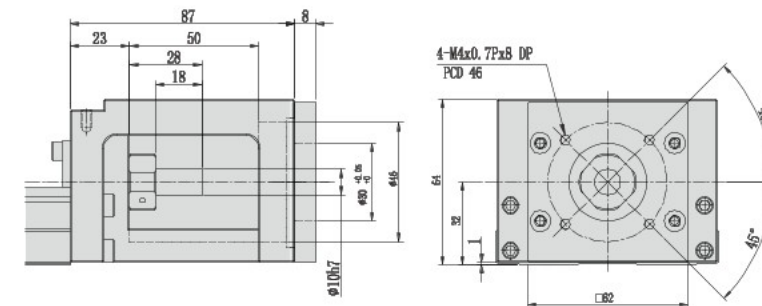

HNR
HCR
HNB
HCB
HNT
XYZ
ONB
OCB
GCR
GCB
GCBS
GCRS
ESR
EMR
EHR
KSR
LNP
DDR
参考资料
Reference data



重复精度
Repeat Accuracy
±0.005
mm

此图仅供参考, 出货规格详见尺寸图面
This picture for reference only, specs details according with the drawing.

最大行程
Max Stroke 1128mm

最高速度
Max Speed 1000mm/sec

滚珠螺杆
Ball Screw Ø 20 mm

型号表达方式 Ordering method

TPA-KSR-10020CK-340A1-M-F0S2-N3-D-F

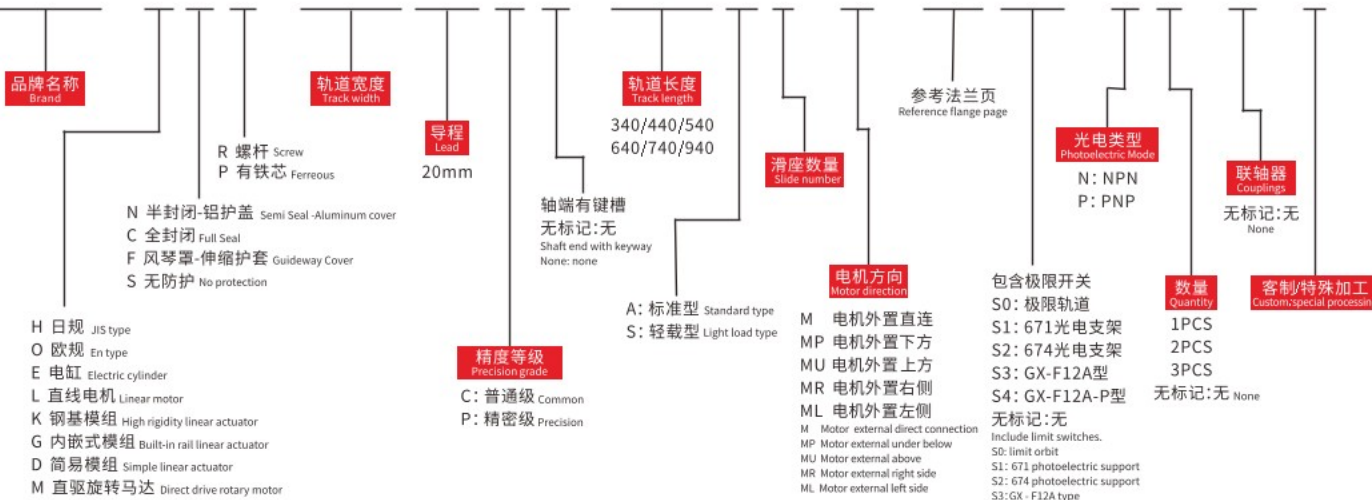

负载规格 Load specification

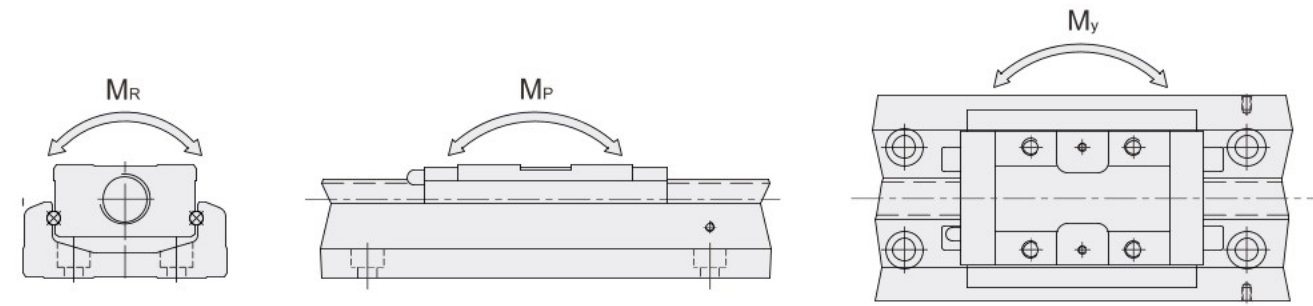

技术参数 Technical parameter

型号 Model	滚珠螺杆 Ballscrew				线性滑轨 Linear slider rail															
	公称外径 (mm)	导程 (mm)	基本动态额定负荷 (N)	基本静态额定负荷 (N)	基本动态额定负荷 (N)		基本静态额定负荷 (N)		容许静力矩 Allowable static moment											
					滑座 A	滑座 S	滑座 A	滑座 S	俯仰 My (N-m)			偏摆 M _y (N-m)			滚动 M _g (N-m)					
KSR 10020	20	20	7046	12544	39200	-	63406	-	960	4763	-	-	960	4763	-	-	2205	4410	-	-

精度等级 Precision grade

型号 Model	轨道长度 Track length	定位重现性 Positioning reproducibility		定位精度 Positioning accuracy		行走平行度 Walking parallelism		最大启动扭力: (N-cm) Maximum starting torque	
		精密级 Precise grade	一般级 General grade	精密级 Precise grade	一般级 General grade	精密级 Precise grade	一般级 General grade	精密级 Precise grade	一般级 General grade
		KSR 100	980	±0.005	±0.02	0.035	-	0.025	-
	1080	±0.005	±0.02	0.040	-	0.03	-	20	12
	1180	±0.005	±0.02	0.045	-	0.035	-	23	15
	1280	±0.005	±0.02	0.05	-	0.04	-	25	15

最大速度 Maximum speed

型号 Model	滚珠螺杆导程 (mm) Ballscrew lead	轨道长度 L2 (mm) Track length	速度 (mm/sec) Speed	
			精密级 Precise grade	一般级 General grade
KSR 100	20	980	1120	800
		1080	980	800
		1180	750	750
		1280	630	630
		1380	530	530

KSR 外形尺寸(不含护盖)/KNR 外形尺寸(含护盖)
KSR Overall dimensions(without cover)/KNR Overall dimensions(cover included)

M KSR-100 电机外置直连(不含护盖) KSR-100 Motor external direct connection (without cover) 单位:Unit: mm

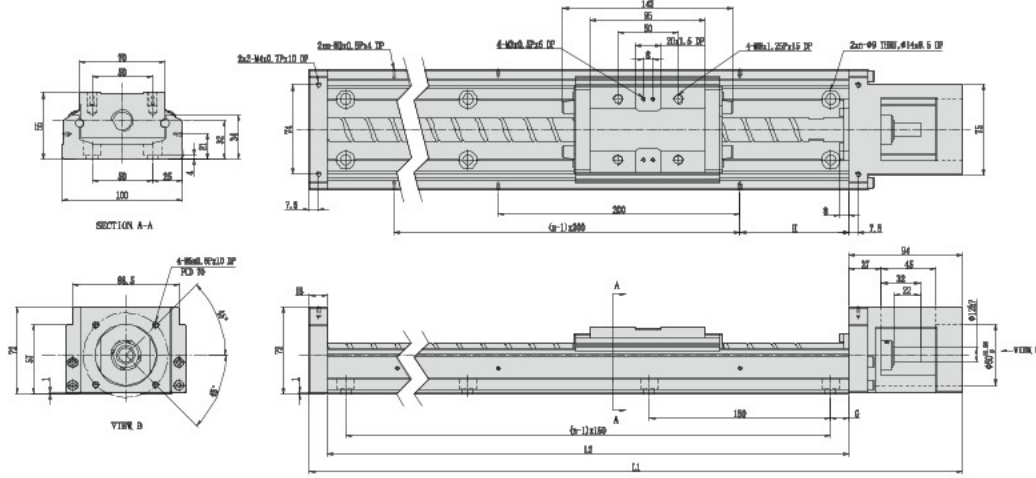

轨道长度 L2 Track length	全长(L1) Full length	最大行程(mm) Maximum travel		G(mm)	H(mm)	n	m	重量(kg) Weight	
		滑座 A1 Slide carriage	滑座 A2 Slide carriage					滑座 A1 Slide carriage	滑座 A2 Slide carriage
980	1089	828	700	40	90	7	5	18.6	20.3
1080	1189	928	800	15	40	8	6	20.3	22
1180	1289	1028	900	65	90	8	6	22	23.7
1280	1389	1128	1000	40	40	9	7	23.6	25.3
1380	1489	1228	1100	15	90	10	7	25.3	27

ML KNR-100 电机外置左侧(含护盖) KNR-100 Motor external left side (Cover included)

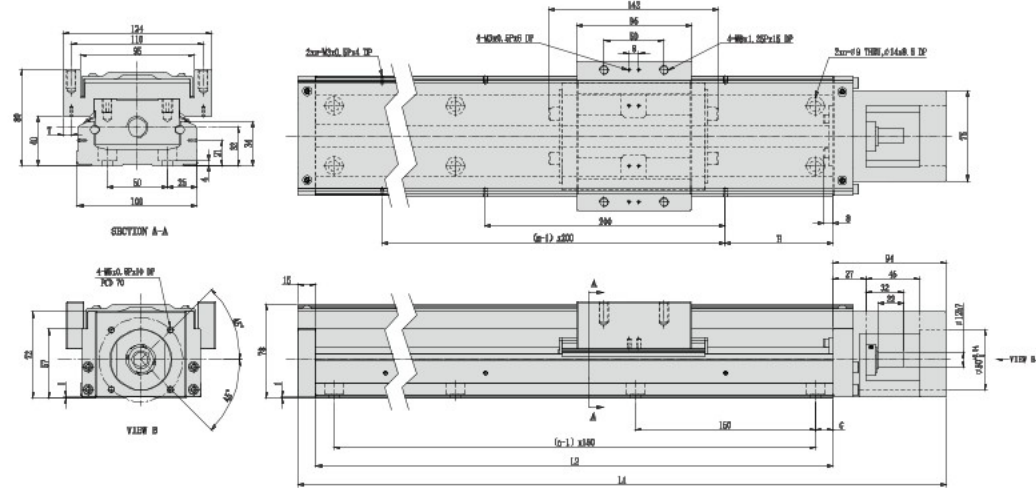

轨道长度 L2 Track length	全长(L1) Full length	最大行程(mm) Maximum travel		G(mm)	H(mm)	n	m	重量(kg) Weight	
		滑座 A1 Slide carriage	滑座 A2 Slide carriage					滑座 A1 Slide carriage	滑座 A2 Slide carriage
980	1089	828	700	40	90	7	5	20.4	22.1
1080	1189	928	800	15	40	8	6	22.2	23.9
1180	1289	1028	900	65	90	8	6	24	25.7
1280	1389	1128	1000	40	40	9	7	25.7	27.4
1380	1489	1228	1100	15	90	10	7	27.5	29.2

电机座与电机连接法兰
Motor seat and motor connecting flange

100 电机座F0(台达/安川/汇川/三菱/富士 200W/400W) Motor seat F0 (Delta/Yaskawa/Inovance/Mitsubishi/Fuji 200W/400W)

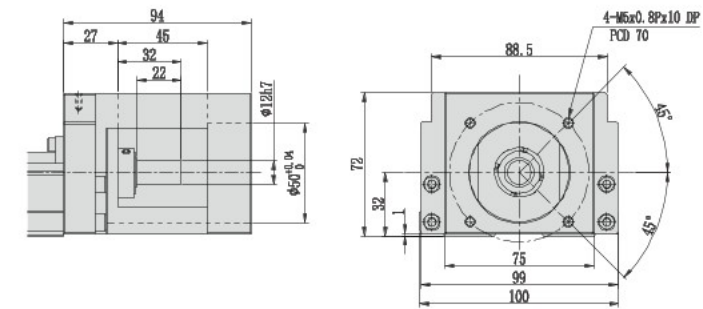

电机座F1(台达/安川/汇川/三菱/富士 750W) Motor seat F1 (Delta/Yaskawa/Inovance/Mitsubishi/Fuji 750W)

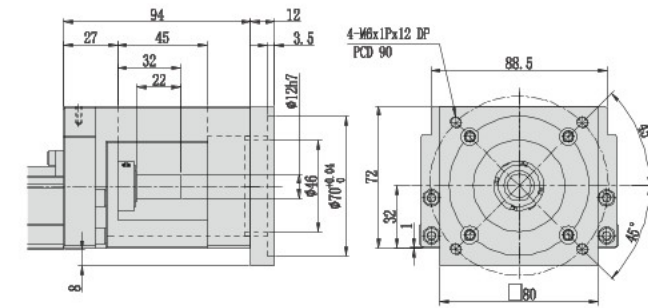

100 电机座F2(松下 750W) Motor seat F2 (Panasonic 750W)

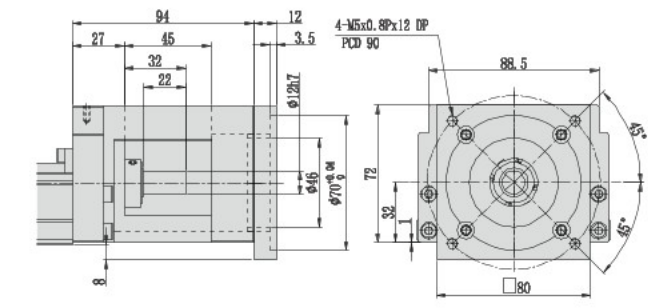

电机座F3 Motor seat F3

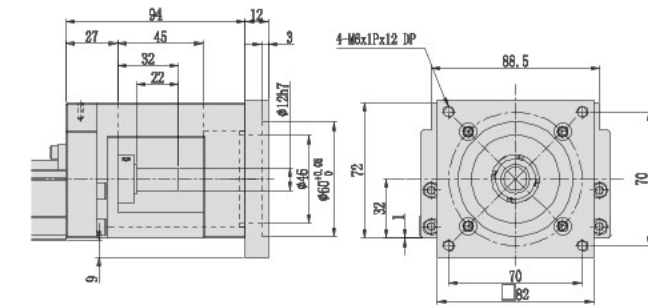

- HNR
- HCR
- HNB
- HCB
- HNT
- XYZ
- ONB
- OCB
- GCR
- GCB
- GCBS
- GCRS
- ESR
- EMR
- EHR
- KSR**
- LNP
- DDR

参考资料
Reference data

电机座与电机连接法兰
Motor seat and motor connecting flange

100 电机座F4(86步进) Motor seat F4(86 Stepper)

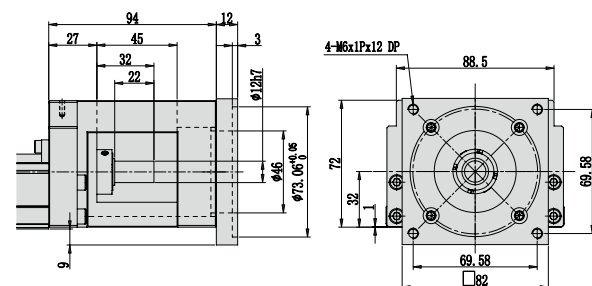

电机座H0 Motor seat H0

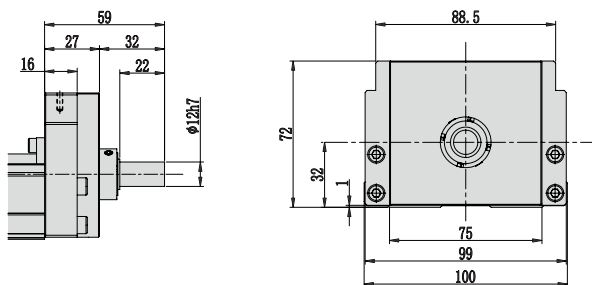

MEMO

- HNR
- HCR
- HNB
- HCB
- HNT
- XYZ
- ONB
- OCB
- GCR
- GCB
- GCBS
- GCRS
- ESR
- EMR
- EHR
- KSR**
- LNP
- DDR

参考资料
Reference
data