



重复精度
Repeat Accuracy
±0.02
mm

此图仅供参考, 出货规格详见尺寸图面
This picture for reference only, specs details according with the drawing.

- 最大行程 Max stroke: 480mm
- 最高速度 Max speed: 100mm/s
- 马达容量 Motor output: 400W
- 滚珠螺杆 Ball screw: Ø8mm
- 直线滑轨 Linear guide: 18X7-1支

型号表达方式 Ordering method

TPA-HCR-40S-0802C-L480-M-Y-P10-N3-F

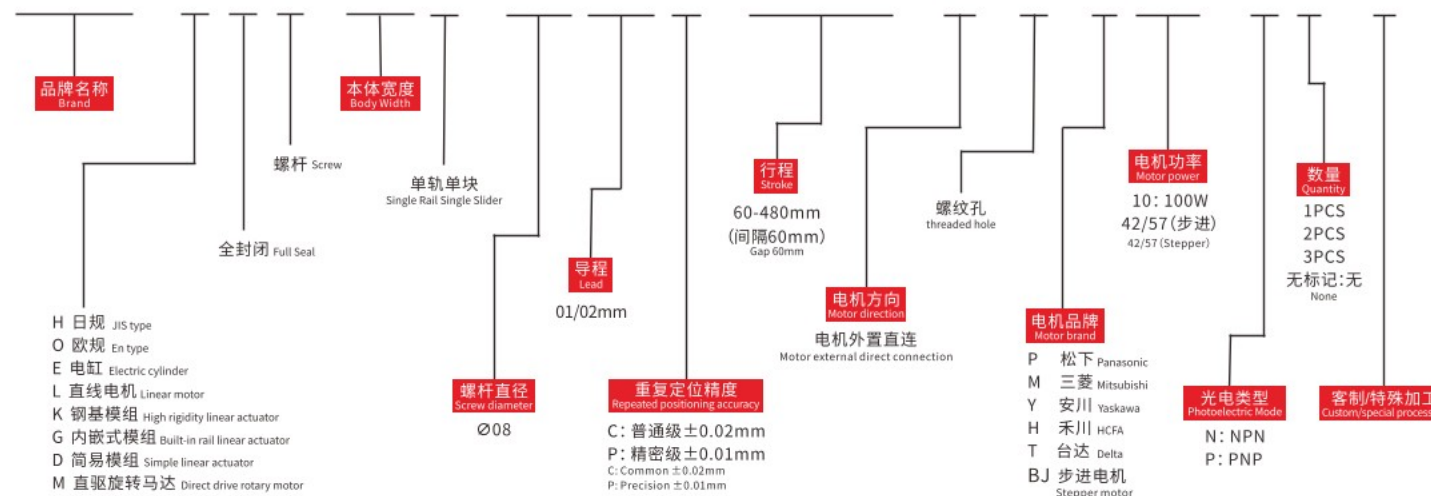

产品性能参数如下 Product performance parameters are as follows

电机功率 (W) Motor power (W)	100	
额定扭矩 (N.M) Rated torque (N.M)	0.32	
重复定位精度 (mm) Repeated positioning accuracy (mm)	±0.02	
导程 (mm) Lead (mm)	1	2
最高速度 (mm/s) Maximum speed (mm/s)	50	100
电机额定转速 (RPM) Rated speed of motor (RPM)	3000	
最大可搬重量 Maximum Payload	水平使用 (kg) Horizontal (kg)	4
	垂直使用 (kg) Vertical (kg)	2
定规格推力 (N) Rated thrust (N)	1537	769
标准行程 (mm) Stroke pitch (mm)	60~480mm/60 间隔 60 mm Pitch	
滚珠螺杆外径 (mm) Ball screw Ø (mm)	Ø8	
基座材质 Material of base	不锈钢/合金钢 Stainless steel/alloy steel	
安装面精度要求 (mm) Accuracy requirements of installation surface (mm)	C级<0.05; P级<0.02 C level<0.05 P level<0.02	
使用环境 Operating environment	0~40°C, 85%RH (无凝结) No condensation	

注1: 使用非上述功率电机时请依据实际参数推算。
Note 1: When using a motor with a power other than the above, please calculate according to the actual parameters.

注2: 最高速度因行程和负载而异, 当螺杆细长比大于1:50时, 可能会因螺杆临界速度产生共振和抖动, 应适当下调运行速度, 一般螺杆每增长100mm, 速度应下调10~15%。
Note 2: The maximum speed varies with stroke and load. When the screw slenderness ratio is greater than 1:50, resonance and jitter may occur due to the critical speed of the screw, so the running speed should be reduced appropriately. Generally, the speed should be reduced by 10~15% for every 100mm increase of the screw.

传感器连接图<原点及端点> Sensor layout

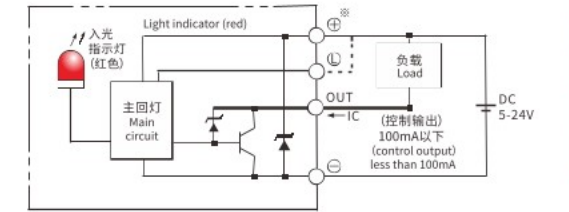

容许负载力矩表 N.m Allowable overhang

	(单位Unit:mm)			
	水平安装 Horizontal installation	A	B	C
导程 1 Lead	1.5kg	289	58	120
导程 2 Lead	3kg	149	22	50
导程 1 Lead	-	-	-	-
导程 2 Lead	-	-	-	-

	(单位Unit:mm)			
	侧面安装 Side mounting	A	B	C
导程 1 Lead	1.5kg	99	34	250
导程 2 Lead	3kg	33	0.6	98
导程 1 Lead	-	-	-	-
导程 2 Lead	-	-	-	-

	(单位Unit:m)		
	垂直安装 Vertical installation	A	C
导程 1 Lead	1kg	83	83
导程 2 Lead	-	-	-
导程 1 Lead	-	-	-
导程 2 Lead	-	-	-

*力矩表所表示的数据, 代表重心。
The torque value in the chart indicate the center of gravity.

*符合录规范的正常使用下, 保证寿命为10000公里。
Operation life is 10,000km when the product is using under the specified conditions.

*侧吊使用无法套用标准规范, 如有需求请咨询我司业务。
The standard specification cannot be applied to the use of inverted crane. Please consult our business if necessary.

静态容许负载惯量 Static loading moment

	(单位Unit:N.m)
MY	16
MP	20
MR	19

搭配伺服马达一览表 Suitable motor brand

品牌 Brand	马达记号 Mark	刹车有无 Brake	马达容量 Motor capacity	电源电压 AC-Voltage	伺服马达型号 Servo motor model	驱动器型号 Driver Model
三菱 Mitsubishi	M	无刹车(水平式样) No brake (horizontal type)	200	220	HG-KR73	MR-J4-70A
松下 Panasonic	P	无刹车(水平式样) No brake (horizontal type)	200	220	MHMD082G1U	MBDHT3520
台达 Delta	T	无刹车(水平式样) No brake (horizontal type)	200	220	ECMA-C20807ES	ASD-B20721-B



电机外置直连
Motor external direct connection

M 电机外置直连 Motor external direct connection

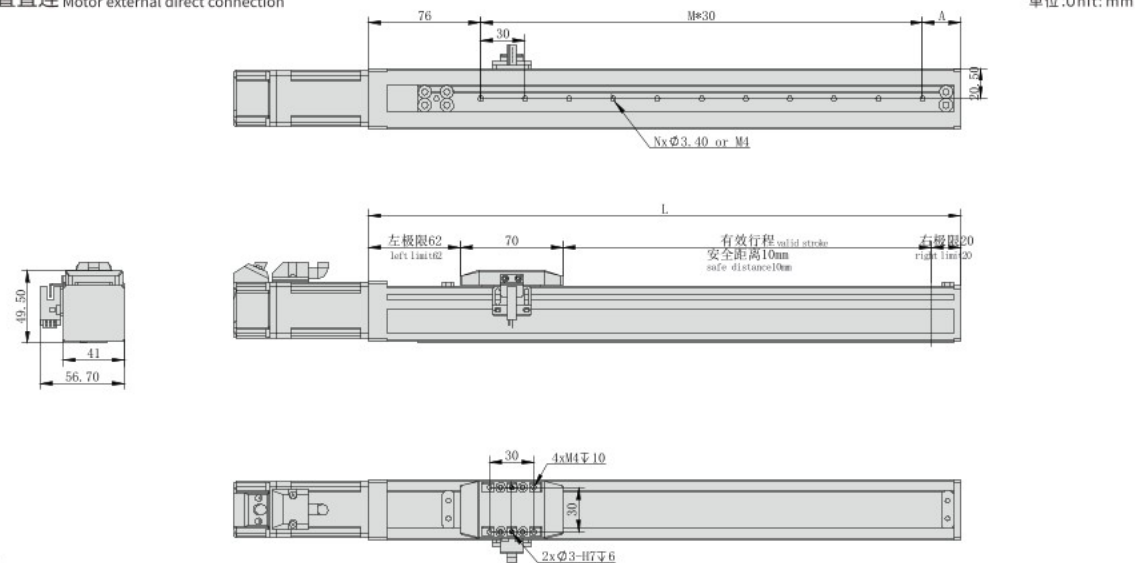

*不含电机重量。*Motor weight not included.

有效行程 Stroke	60	120	180	240	300	360	420	480
L	222	282	342	402	462	522	582	642
A	26	26	26	26	26	26	26	26
N	5	7	9	11	13	15	17	19
M	4	6	8	10	12	14	16	18
KG	0.7	1	1.3	1.6	1.9	2.2	2.5	2.8

如有超长行程及定制需求, 请咨询我司业务。 If you have extra long trip and custom requirements, please consult our business.

知识小课堂 Knowledge classroom

日规模组原理 Theory of Asia Standard Linear Actuator

伺服滑台是一种将伺服马达、滚珠螺杆(或同步带、齿轮齿条)、导轨等相结合的一种小型设备, 通过电机旋转运动来驱动传动结构转换成直线运动, 从而实现高精度、高速度、高负载的直线运行工作。

Servo slide table is a kind of small equipment which combines servo motor, ball screw (or synchronous belt, rack and pinion) and guide rail. The transmission structure is converted into linear motion through the rotary motion of the motor, so as to realize high-precision, high-speed and high-load linear operation.

日规模组特点 Feature of Asia Standard Linear Actuator

伺服滑台作为一款小型集成设备有着许多特点, 精度高、重复定位精度最高可达 $\pm 0.008\text{mm}$, 运行速度快、可以采用螺杆、同步带及齿轮齿条等传动方式, 安装方便、可在恶劣的工作环境下无故障运行; 本体质量轻、占设备空间小, 高刚性、寿命长、噪音低、控制简单、维护方便等。

As a small integrated equipment, the servo slide table has many characteristics, such as high precision, repeated positioning accuracy up to $\pm 0.01\text{mm}$, fast running speed, convenient installation and trouble-free operation in harsh working environment. Light weight, small equipment space, high rigidity, long service life, low noise, simple control and convenient maintenance.

日规模组产品优势 Product advantage of Asia Standard Linear Actuator

1、传动结构多样化 Diversification of transmission structure

作为一款小型集成设备, 滑台在结构方面既简单又有着多样的选择性, 目前广泛使用的可分为三类型, 滚珠螺杆型、同步带型以及齿轮齿条形式, 可适用于不同的工作环境。

As a small integrated equipment, the sliding table is simple in structure and has a variety of options. At present, it can be widely used in three types: ball screw type, synchronous belt type and rack and pinion type, which can be applied to different working environments.

2、控制简单、适用性强 Simple control and strong applicability

由伺服、步进等电机驱动, 既有着伺服电机的高精度、也有滑台本身高速度、高刚性的优势, 操控简单可轻易与PLC等系统连接。

Driven by servo, stepper and other motors, it not only has the high precision of servo motor, but also has the advantages of high speed and high rigidity of sliding table itself. It is easy to control and can be easily connected with PLC and other systems.

3、安装便捷、尺寸可非标化 Convenient installation and nonstandard size

滑台采用的是一体挤压成型铝型材, 本体质量轻、尺寸小、刚性强、安装尺寸、行程都可以按客户要求非标定制, 安装使用螺栓固定便可。

The sliding table is made of integrally extruded aluminum profile, with light weight, small size and strong rigidity. The installation size and stroke can be customized according to the requirements, and the installation can be fixed by bolts.

4、组合搭建 Combined construction

滑台可通过多放向的组合, 组成设备上的运动执行机构, 例如工业机械手XYZ轴机械手、坐标轴滑台等。

The sliding table can be combined with multiple directions to form the motion executing mechanism on the equipment, such as XYZ axis manipulator, coordinate axis sliding table and so on.

- HNR
- HCR
- HNB
- HCB
- HNT
- XYZ
- ONB
- OCB
- GCR
- GCB
- GCBS
- GCRS
- ESR
- EMR
- EHR
- KSR
- LNP
- DDR
- 参考资料
Reference data



重复精度
Repeat Accuracy
±0.02
mm

此图仅供参考, 出货规格详见尺寸图面
This picture for reference only, specs details according with the drawing.

- 最大行程 Max stroke: 660mm
- 最高速度 Max speed: 500mm/s
- 马达容量 Motor output: 100W
- 滚珠螺杆 Ball screw: Ø12mm
- 直线滑轨 Linear guide: 24X8.5-1支

型号表达方式 Ordering method

TPA-HCR-50S-1210C-L660-M-Y-P10-N3-F

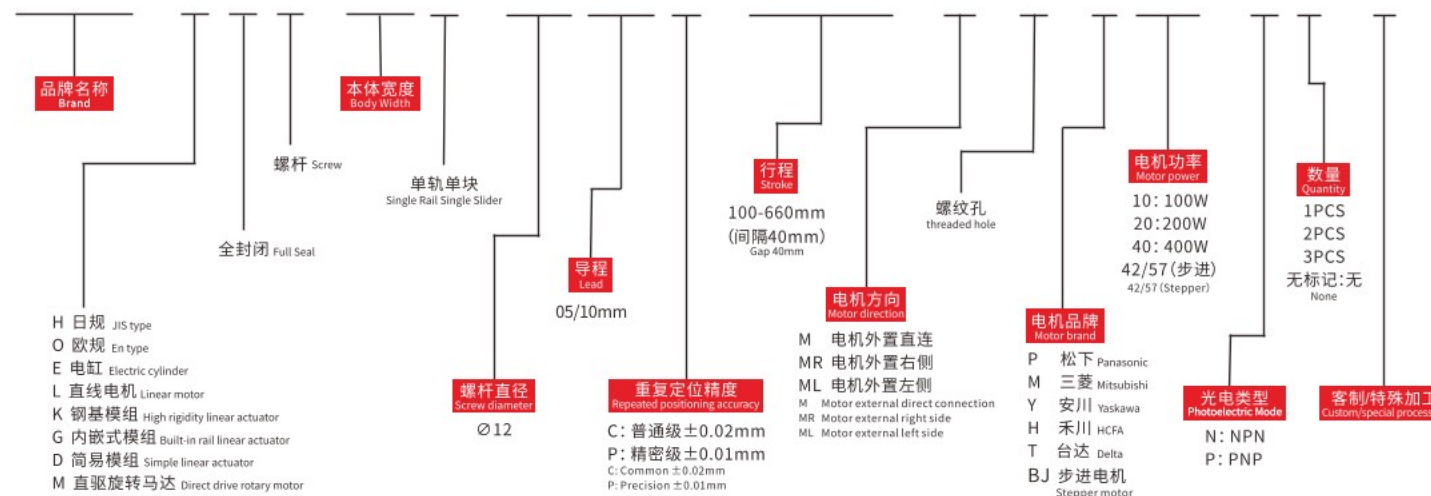

产品性能参数如下 Product performance parameters are as follows

电机功率(W) Motor power (W)	100	
额定扭矩(N.M) Rated torque (N.M)	0.32	
重复定位精度(mm) Repeated positioning accuracy (mm)	±0.02	
导程(mm) Lead (mm)	5	10
最高速度(mm/s) Maximum speed (mm/s)	250	500
电机额定转速(RPM) Rated speed of motor (RPM)	3000	
最大可搬重量 Maximum Payload	水平使用(kg) Horizontal(kg)	10
	垂直使用(kg) Vertical(kg)	6
定格推力(N) Rated thrust (N)	307	153
标准行程(mm) Stroke pitch (mm)	100~660mm/40 间隔 40 mm Pitch	
滚珠螺杆外径(mm) Ball screw Ø (mm)	Ø12	
基座材质 Material of base	不锈钢/合金钢 Stainless steel/alloy steel	
安装面精度要求(mm) Accuracy requirements of installation surface (mm)	C级<0.05; P级<0.02 C level<0.05 P level<0.02	
使用环境 Operating environment	0~40°C, 85%RH(无凝结) No condensation	

注1: 使用非上述功率电机时请依据实际参数推算。
Note 1: When using a motor with a power other than the above, please calculate according to the actual parameters.

注2: 最高速度因行程和负载而异, 当螺杆细长比大于1:50时, 可能会因螺杆临界速度产生共振和抖动, 应适当下调运行速度, 一般螺杆每增长100mm, 速度应下调10~15%。
Note 2: The maximum speed varies with stroke and load. When the screw slenderness ratio is greater than 1:50, resonance and jitter may occur due to the critical speed of the screw, so the running speed should be reduced appropriately. Generally, the speed should be reduced by 10~15% for every 100mm increase of the screw.

容许负载力矩表 N.m Allowable overhang

(单位Unit:mm)				(单位Unit:mm)				(单位Unit:mm)					
水平安装 Horizontal installation				侧面安装 Side mounting				垂直安装 Vertical installation					
导程 Lead	A	B	C	导程 Lead	A	B	C	导程 Lead	A	C	导程 Lead	A	C
5	4kg	515	58	135	4kg	107	24	380	3kg	56	57	-	-
5	7kg	340	26	62	7kg	31	-	195	-	-	-	-	-
10	3kg	433	87	180	3kg	149	54	376	1.5kg	125	125	-	-
10	5kg	223	33	75	5kg	50	1	148	-	-	-	-	-

*力矩表所表示的数据, 代表重心。
The torque value in the chart indicate the center of gravity.

*符合录型规范的正常试用下, 保证寿命为10000公里。
Operation life is 10,000km when the product is using under the specified conditions.

*倒吊使用无法套用标准规范, 如有需求请咨询我司业务。
The standard specification cannot be applied to the use of inverted crane. Please consult our business if necessary.

搭配伺服马达一览表 Suitable motor brand

品牌 Brand	马达记号 Mark	刹车有无 Brake	马达容量 Motor capacity	电源电压 AC-Voltage	伺服马达型号 Servo motor model	驱动器型号 Driver Model
三菱 Mitsubishi	M	无刹车(水平式样) No brake (horizontal type)	200	220	HG-KR73	MR-J4-70A
松下 Panasonic	P	无刹车(水平式样) No brake (horizontal type)	200	220	MHMD082G1U	MBDHT3520
台达 Delta	T	无刹车(水平式样) No brake (horizontal type)	200	220	ECMA-C20807ES	ASD-B20721-B

感应器连接图<原点及端点> Sensor layout

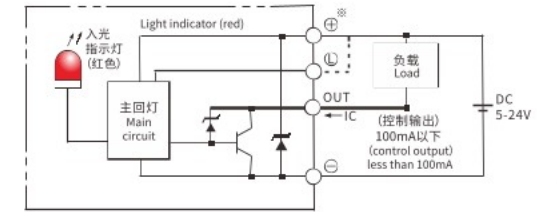

- HNR
- HCR
- HNB
- HCB
- HNT
- XYZ
- ONB
- OCB
- GCR
- GCB
- GCBS
- GCRS
- ESR
- EMR
- EHR
- KSR
- LNP
- DDR
- 参考资料 Reference data

静态容许负载惯量 Static loading moment

(单位Unit:N.m)	
MY	16
MP	20
MR	19



电机外置直连/电机外置左侧
Motor external direct connection/Motor external left side

M 电机外置直连 Motor external direct connection

单位:Unit: mm

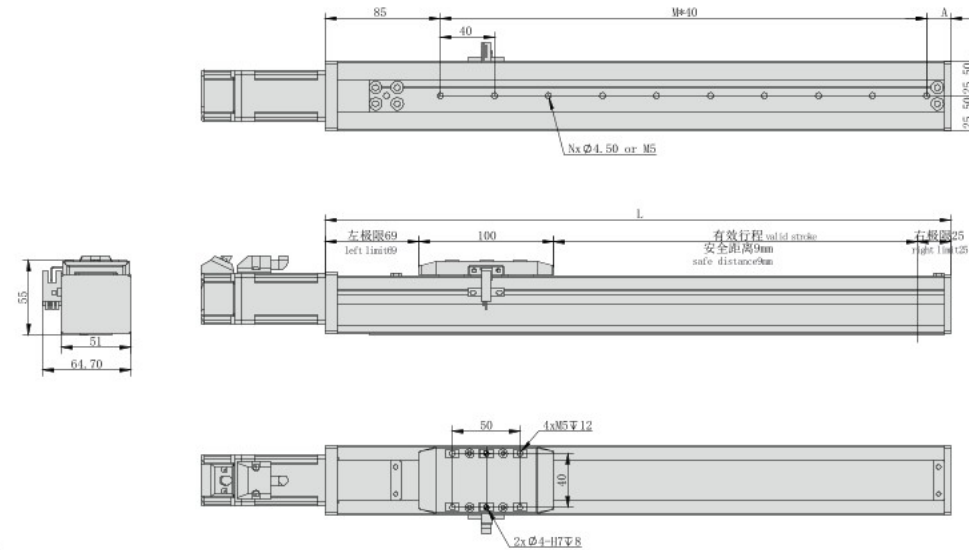

*不含电机重量。*Motor weight not included.

有效行程 Stroke	100	140	180	220	260	300	340	380	420	460	500	540	580	620	660
L	303	343	383	423	463	503	543	583	623	663	703	743	783	823	863
A	18	18	18	18	18	18	18	18	18	18	18	18	18	18	18
N	6	7	8	9	10	11	12	13	14	15	16	17	18	19	20
M	5	6	7	8	9	10	11	12	13	14	15	16	17	18	19
KG	1.3	1.6	1.9	2.2	2.5	2.8	3.1	3.4	3.7	4	4.3	4.6	4.9	5.2	5.5

如有超长行程及定制需求, 请咨询我司业务。If you have extra long trip and custom requirements, please consult our business.

电机外置右侧
Motor external right side

MR 电机外置右侧 Motor external right side

单位:Unit: mm

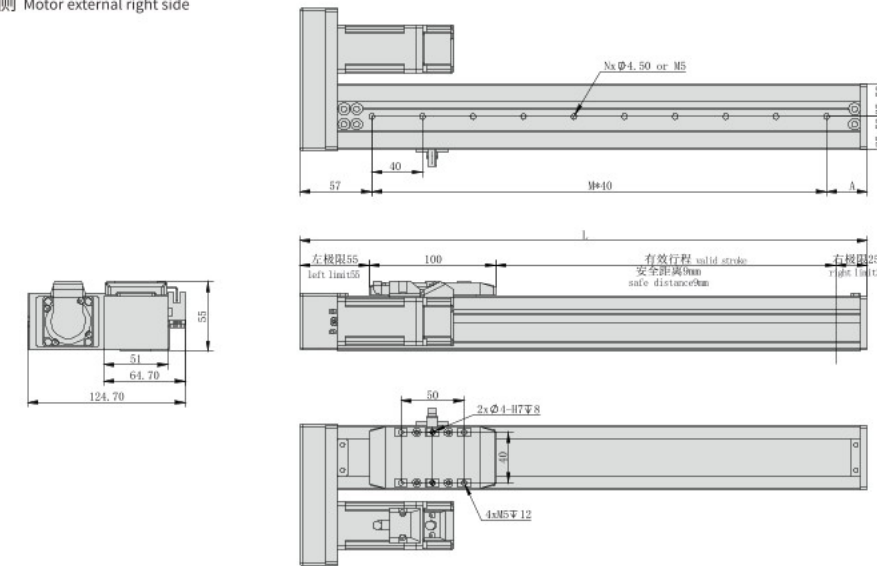

*不含电机重量。*Motor weight not included.

有效行程 Stroke	100	140	180	220	260	300	340	380	420	460	500	540	580	620	660
L	289	329	369	409	449	489	529	569	609	649	689	729	769	809	849
A	32	32	32	32	32	32	32	32	32	32	32	32	32	32	32
N	4	5	6	7	8	9	10	11	12	13	14	15	16	17	18
M	6	7	8	9	10	11	12	13	14	15	16	17	18	19	20
KG	1.1	1.4	1.7	2	2.3	2.6	2.9	3.2	3.5	3.8	4.1	4.4	4.7	5	5.3

如有超长行程及定制需求, 请咨询我司业务。If you have extra long trip and custom requirements, please consult our business.

ML 电机外置左侧 Motor external left side

单位:Unit: mm

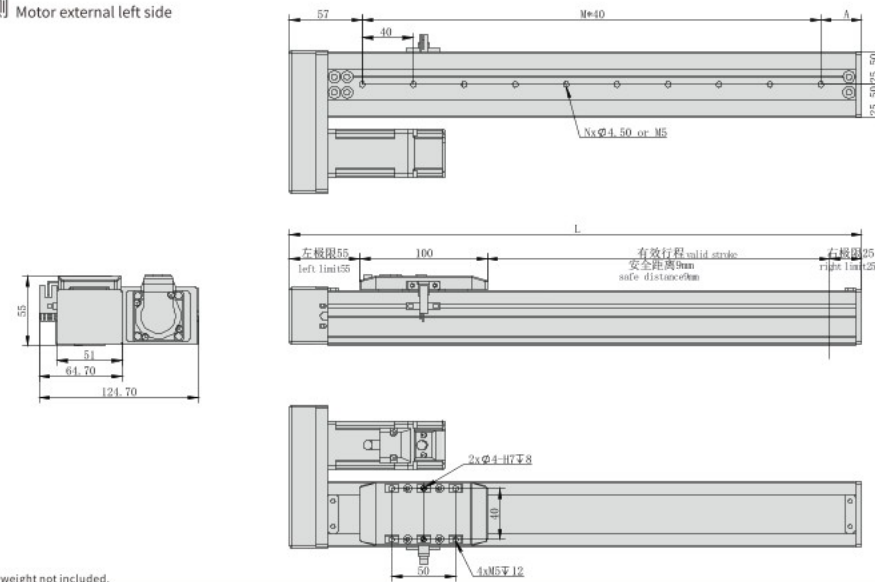

*不含电机重量。*Motor weight not included.

有效行程 Stroke	100	140	180	220	260	300	340	380	420	460	500	540	580	620	660
L	289	329	369	409	449	489	529	569	609	649	689	729	769	809	849
A	32	32	32	32	32	32	32	32	32	32	32	32	32	32	32
N	4	5	6	7	8	9	10	11	12	13	14	15	16	17	18
M	6	7	8	9	10	11	12	13	14	15	16	17	18	19	20
KG	1.1	1.4	1.7	2	2.3	2.6	2.9	3.2	3.5	3.8	4.1	4.4	4.7	5	5.3

如有超长行程及定制需求, 请咨询我司业务。If you have extra long trip and custom requirements, please consult our business.

- HNR
- HCR
- HNB
- HCB
- HNT
- XYZ
- ONB
- OCB
- GCR
- GCB
- GCBS
- GCRS
- ESR
- EMR
- EHR
- KSR
- LNP
- DDR

参考资料
Reference data



重复精度
Repeat Accuracy
±0.02
mm

此图仅供参考, 出货规格详见尺寸图面
This picture for reference only, specs details according with the drawing.

- 最大行程 Max stroke: 1200mm
- 最高速度 Max speed: 1000mm/s
- 马达容量 Motor output: 200W
- 滚珠螺杆 Ball screw: Ø16mm
- 直线滑轨 Linear guide: 42X9.5-1支

型号表达方式 Ordering method

TPA-HCR-65S-1610C-L1200-M-Y-P20-N3-F

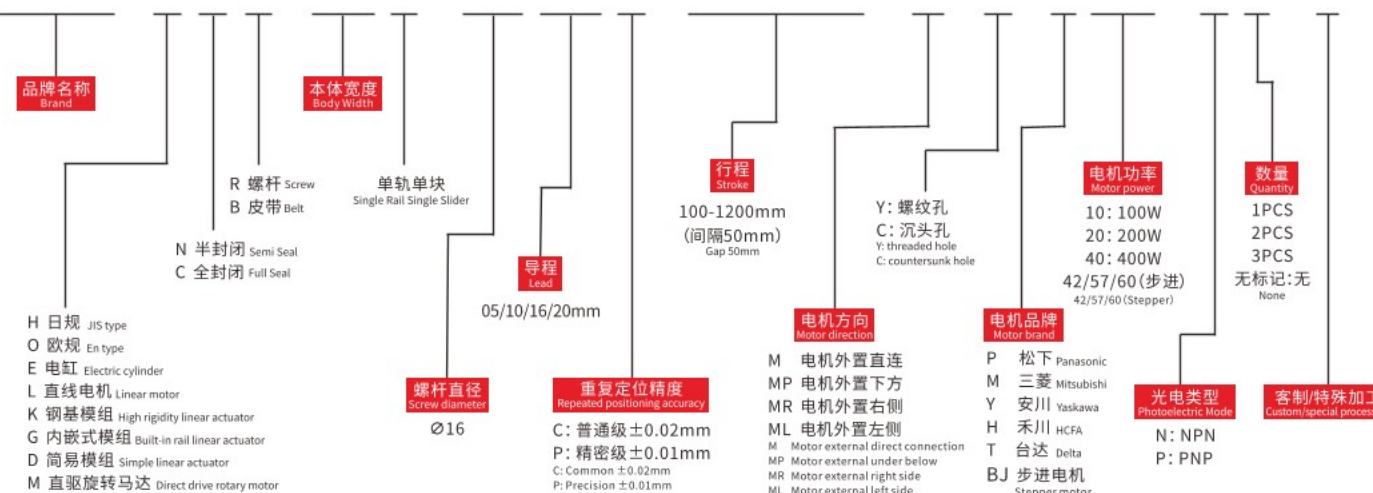

产品性能参数如下 Product performance parameters are as follows

电机功率 (W) Motor power (W)	100				
额定扭矩 (N.M) Rated torque (N.M)	0.32				
重复定位精度 (mm) Repeated positioning accuracy (mm)	±0.02				
导程 (mm) Lead (mm)	5	10	16	20	
最高速度 (mm/s) Maximum speed (mm/s)	250	500	800	1000	
电机额定转速 (RPM) Rated speed of motor (RPM)	3000				
最大可搬重量 Maximum Payload	水平使用 (kg) Horizontal (kg)	36	18	14	9
	垂直使用 (kg) Vertical (kg)	16	8	6	4
定格推力 (N) Rated thrust (N)	307	154	96	77	
标准行程 (mm) Stroke pitch (mm)	100~1200mm/50 间隔 50 mm Pitch				
滚珠螺杆外径 (mm) Ball screw Ø (mm)	Ø16				
基座材质 Material of base	硬质挤压铝材A1 Hard extruded aluminum A1				
安装面精度要求 (mm) Accuracy requirements of installation surface (mm)	C级<0.05; P级<0.02 C level<0.05 P level<0.02				
使用环境 Operating environment	0~40°C, 85%RH (无凝结) No condensation				

注1: 使用非上述功率电机时请依据实际参数推算。
Note 1: When using a motor with a power other than the above, please calculate according to the actual parameters.

注2: 最高速度因行程和负载而异, 当螺杆细长比大于1:50时, 可能会因螺杆临界速度产生共振和抖动, 应适当下调运行速度, 一般螺杆每增长100mm, 速度应下调10~15%。
Note 2: The maximum speed varies with stroke and load. When the screw slenderness ratio is greater than 1:50, resonance and jitter may occur due to the critical speed of the screw, so the running speed should be reduced appropriately. Generally, the speed should be reduced by 10~15% for every 100mm increase of the screw.

容许负载力矩表 N.m Allowable overhang

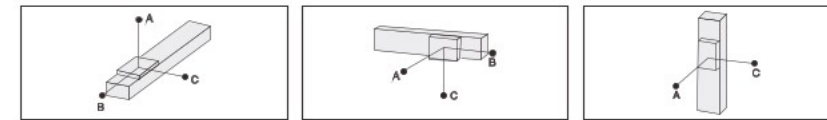

水平安装 Horizontal installation (单位Unit:mm)					侧面安装 Side mounting (单位Unit:mm)					垂直安装 Vertical installation (单位Unit:mm)				
导程 Lead	A	B	C	重量 Weight	导程 Lead	A	B	C	重量 Weight	导程 Lead	A	B	C	重量 Weight
5	14kg	111	80	53	5	14kg	26	65	132	5	6kg	94	94	
10	17kg	89	60	46	10	17kg	14	54	87	10	8kg	73	73	
16	36kg	50	-	-	16	36kg	-	-	9	16	16kg	-	-	27
20	9kg	139	114	94	20	9kg	56	98	155	20	2kg	326	326	
	14kg	81	61	35		14kg	13	51	73		4kg	211	211	
	18kg	40	-	-		18kg	-	5	22		8kg	91	91	
	7kg	287	29	180		7kg	85	66	199		1kg	215	215	
	10kg	196	157	131		10kg	50	94	138		3kg	120	120	
	14kg	135	51	42		14kg	8	27	61		6kg	59	59	
	3kg	118	150	266		3kg	40	53	110		1kg	205	205	
	5kg	83	105	155		5kg	29	16	84		2kg	96	96	
	9kg	39	96	92		9kg	-	-	21		4kg	40	40	

感应器连接图<原点及端点> Sensor layout

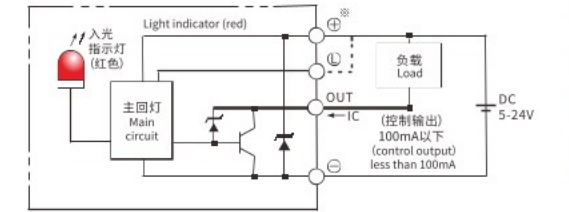

- HNR
- HCR
- HNB
- HCB
- HNT
- XYZ
- ONB
- OCB
- GCR
- GCB
- GCBS
- GCRS
- ESR
- EMR
- EHR
- KSR
- LNP
- DDR
- 参考资料 Reference data

静态容许负载惯量 Static loading moment

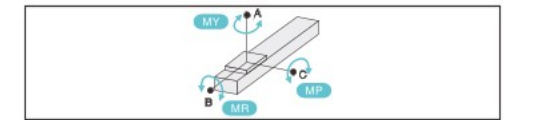

点 Point	惯量 Inertia (单位Unit:N.m)
MY	16
MP	20
MR	19

*力矩表所表示的数据, 代表重心。
The torque value in the chart indicate the center of gravity.

*符合型录规范的正常试用下, 保证寿命为10000公里。
Operation life is 10,000km when the product is using under the specified conditions.

*倒吊使用无法套用标准规范, 如有需求请咨询我司业务。
The standard specification cannot be applied to the use of inverted crane. Please consult our business if necessary.

搭配伺服马达一览表 Suitable motor brand

品牌 Brand	马达记号 Mark	刹车有无 Brake	马达容量 Motor capacity	电源电压 AC-Voltage	伺服马达型号 Servo motor model	驱动器型号 Driver Model
三菱 Mitsubishi	M	无刹车(水平式样) No brake (horizontal type)	200	220	HG-KR73	MR-J4-70A
松下 Panasonic	P	无刹车(水平式样) No brake (horizontal type)	200	220	MHMD082G1U	MBDHT3520
台达 Delta	T	无刹车(水平式样) No brake (horizontal type)	200	220	ECMA-C20807ES	ASD-B20721-B



电机外置直连/电机外置下方
Motor external direct connection/Motor external under below

M 电机外置直连 Motor external direct connection

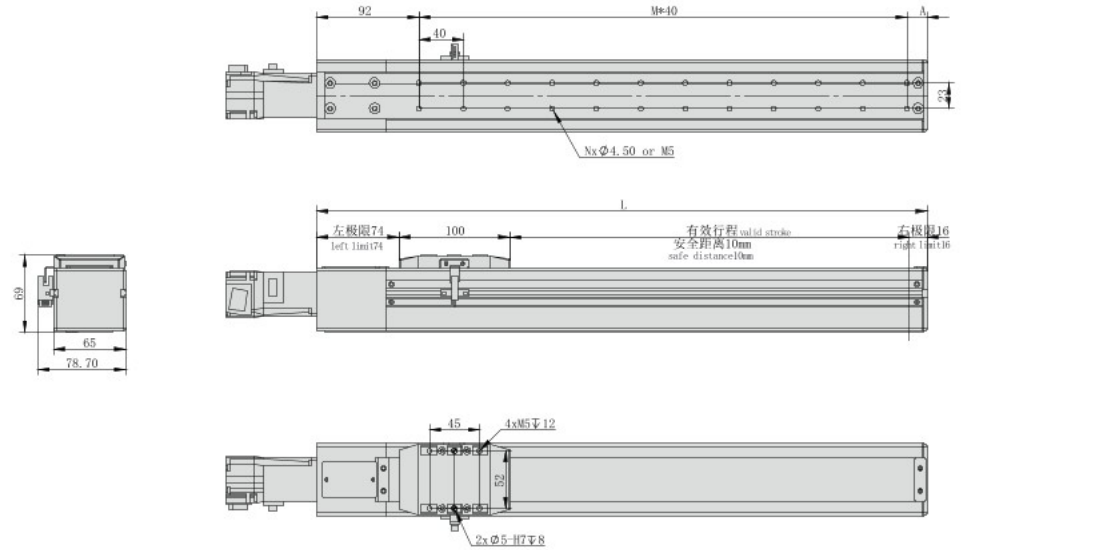

单位:Unit: mm

*不含电机重量。*Motor weight not included.

有效行程 Stroke	100	150	200	250	300	350	400	450	500	550	600	650	700	750	800	850	900	950	1000	1050	1100	1150	1200
L	300	350	400	450	500	550	600	650	700	750	800	850	900	950	1000	1050	1100	1150	1200	1250	1300	1350	1400
A	48	18	28	38	48	18	28	38	48	18	28	38	48	18	28	38	48	18	28	38	48	18	28
N	10	14	16	18	20	24	26	28	30	34	36	38	40	44	46	48	50	54	56	58	60	64	66
M	4	6	7	8	9	11	12	13	14	16	17	18	19	21	22	23	24	26	27	28	29	31	32
KG	2.5	2.9	3.3	3.7	4.1	4.5	4.9	5.3	5.7	6.1	6.5	6.9	7.3	7.7	8.1	8.5	8.9	9.3	9.7	10.1	10.5	10.9	11.3

如有超长行程及定制需求, 请咨询我司业务。If you have extra long trip and custom requirements, please consult our business.

电机外置左侧/电机外置右侧
Motor external left side / Motor external right side

ML 电机外置左侧 Motor external left side

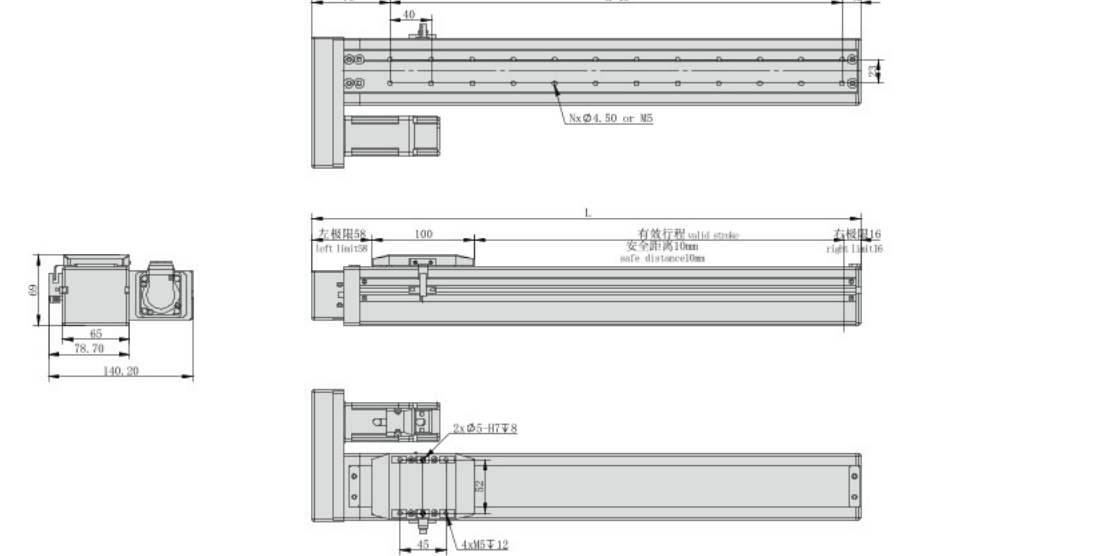

单位:Unit: mm

*不含电机重量。*Motor weight not included.

有效行程 Stroke	100	150	200	250	300	350	400	450	500	550	600	650	700	750	800	850	900	950	1000	1050	1100	1150	1200
L	284	334	384	434	484	534	584	634	684	734	784	834	884	934	984	1034	1084	1134	1184	1234	1284	1334	1384
A	48	18	28	38	48	18	28	38	48	18	28	38	48	18	28	38	48	18	28	38	48	18	28
N	10	14	16	18	20	24	26	28	30	34	36	38	40	44	46	48	50	54	56	58	60	64	66
M	4	6	7	8	9	11	12	13	14	16	17	18	19	21	22	23	24	26	27	28	29	31	32
KG	2.7	3.1	3.5	3.9	4.3	4.7	5.1	5.5	5.9	6.3	6.7	7.1	7.5	7.9	8.3	8.7	9.1	9.5	9.9	10.3	10.7	11.1	11.5

如有超长行程及定制需求, 请咨询我司业务。If you have extra long trip and custom requirements, please consult our business.

MP 电机外置下方 Motor external under below

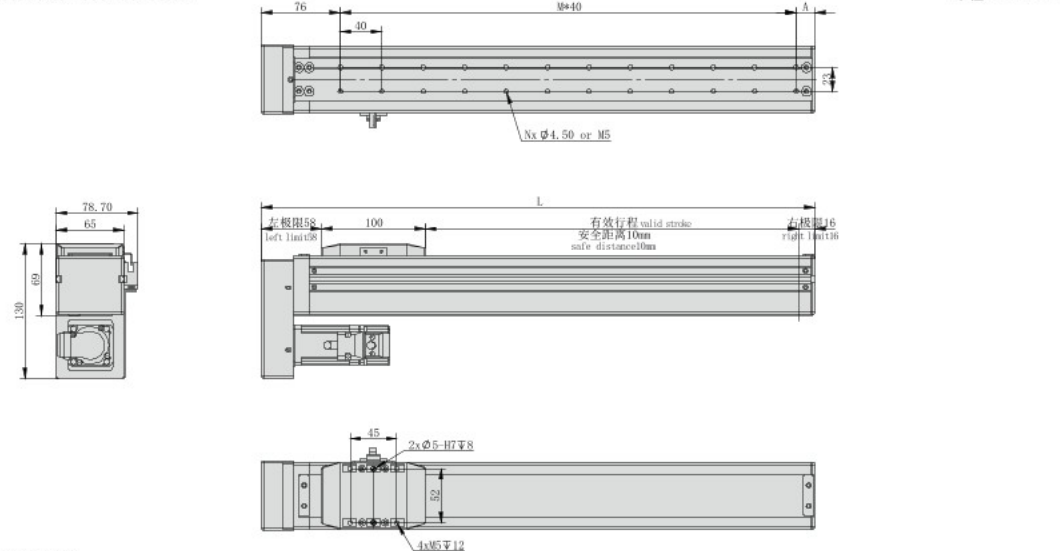

单位:Unit: mm

*不含电机重量。*Motor weight not included.

有效行程 Stroke	100	150	200	250	300	350	400	450	500	550	600	650	700	750	800	850	900	950	1000	1050	1100	1150	1200
L	284	334	384	434	484	534	584	634	684	734	784	834	884	934	984	1034	1084	1134	1184	1234	1284	1334	1384
A	48	18	28	38	48	18	28	38	48	18	28	38	48	18	28	38	48	18	28	38	48	18	28
N	10	14	16	18	20	24	26	28	30	34	36	38	40	44	46	48	50	54	56	58	60	64	66
M	4	6	7	8	9	11	12	13	14	16	17	18	19	21	22	23	24	26	27	28	29	31	32
KG	2.7	3.1	3.5	3.9	4.3	4.7	5.1	5.5	5.9	6.3	6.7	7.1	7.5	7.9	8.3	8.7	9.1	9.5	9.9	10.3	10.7	11.1	11.5

如有超长行程及定制需求, 请咨询我司业务。If you have extra long trip and custom requirements, please consult our business.

MR 电机外置右侧 Motor external right side

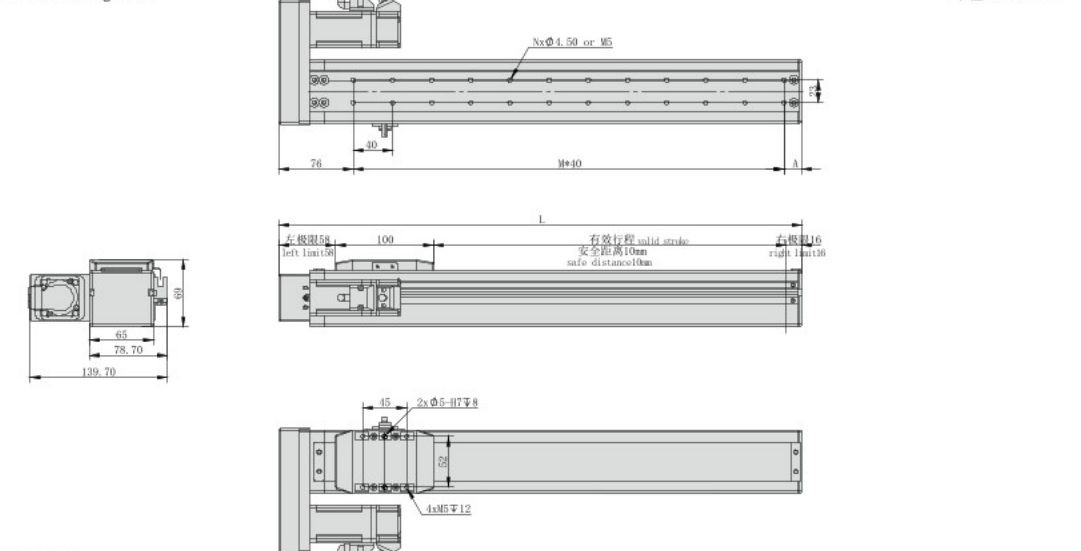

单位:Unit: mm

*不含电机重量。*Motor weight not included.

有效行程 Stroke	100	150	200	250	300	350	400	450	500	550	600	650	700	750	800	850	900	950	1000	1050	1100	1150	1200
L	284	334	384	434	484	534	584	634	684	734	784	834	884	934	984	1034	1084	1134	1184	1234	1284	1334	1384
A	48	18	28	38	48	18	28	38	48	18	28	38	48	18	28	38	48	18	28	38	48	18	28
N	10	14	16	18	20	24	26	28	30	34	36	38	40	44	46	48	50	54	56	58	60	64	66
M	4	6	7	8	9	11	12	13	14	16	17	18	19	21	22	23	24	26	27	28	29	31	32
KG	2.7	3.1	3.5	3.9	4.3	4.7	5.1	5.5	5.9	6.3	6.7	7.1	7.5	7.9	8.3	8.7	9.1	9.5	9.9	10.3	10.7	11.1	11.5

如有超长行程及定制需求, 请咨询我司业务。If you have extra long trip and custom requirements, please consult our business.

- HNR
- HCR
- HNB
- HCB
- HNT
- XYZ
- ONB
- OCB
- GCR
- GCB
- GCBS
- GCRS
- ESR
- EMR
- EHR
- KSR
- LNP
- DDR

参考资料
Reference data



重复精度
Repeat Accuracy
±0.02
mm

此图仅供参考, 出货规格详见尺寸图面
This picture for reference only, specs details according with the drawing.

最大行程 Max stroke 1050mm
最高速度 Max speed 1000mm/s
马达容量 Motor output 200W
滚珠螺杆 Ball screw Ø16mm
直线滑轨 Linear guide 9X6.5-2支

型号表达方式 Ordering method

TPA-HCR-85D-1610C-L1050-M-Y-P20-N3-F

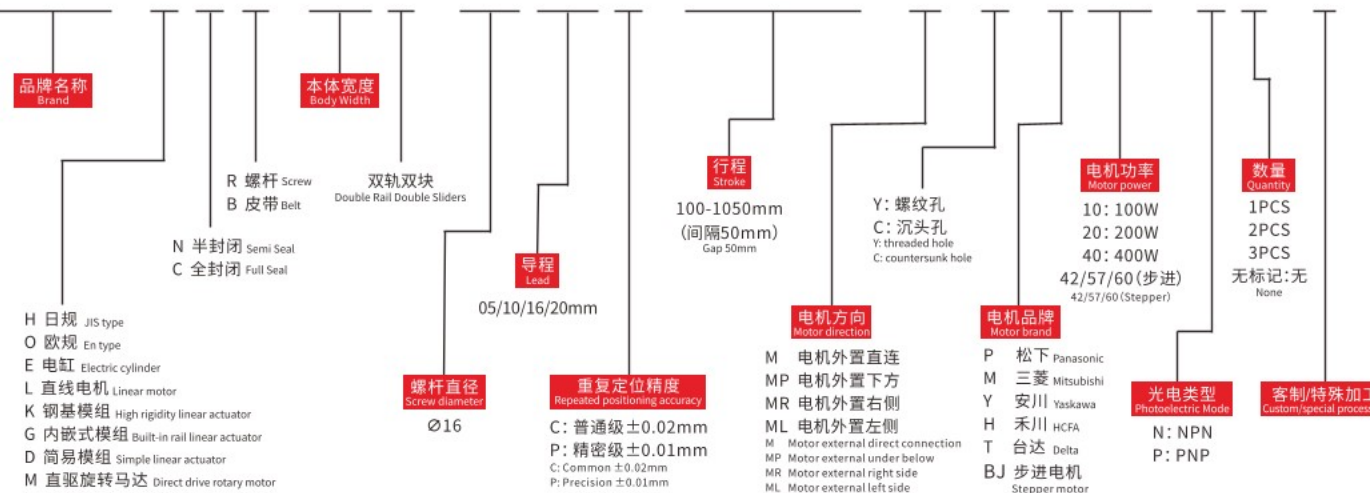

产品性能参数如下 Product performance parameters are as follows

电机功率 (W) Motor power (W)	200				
额定扭矩 (N.M) Rated torque (N.M)	0.64				
重复定位精度 (mm) Repeated positioning accuracy (mm)	±0.02				
导程 (mm) Lead (mm)	5	10	16	20	
最高速度 (mm/s) Maximum speed (mm/s)	250	500	800	1000	
电机额定转速 (RPM) Rated speed of motor (RPM)	3000				
最大可搬重量 Maximum Payload	水平使用 (kg) Horizontal (kg)	40	20	15	10
	垂直使用 (kg) Vertical (kg)	18	9	7	5
定格推力 (N) Rated thrust (N)	615	307	192	154	
标准行程 (mm) Stroke pitch (mm)	100~1050mm/50 间隔 50 mm Pitch				
滚珠螺杆外径 (mm) Ball screw Ø (mm)	Ø16				
基座材质 Material of base	硬质挤压铝材A1 Hard extruded aluminum A1				
安装面精度要求 (mm) Accuracy requirements of installation surface (mm)	C级<0.05; P级<0.02 C level<0.05 P level<0.02				
使用环境 Operating environment	0~40°C, 85%RH (无凝结) No condensation				

注1: 使用非上述功率电机时请依据实际参数推算。
Note 1: When using a motor with a power other than the above, please calculate according to the actual parameters.

注2: 最高速度因行程和负载而异, 当螺杆细长比大于1:50时, 可能会因螺杆临界速度产生共振和抖动, 应适当下调运行速度, 一般螺杆每增长100mm, 速度应下调10~15%。
Note 2: The maximum speed varies with stroke and load. When the screw slenderness ratio is greater than 1:50, resonance and jitter may occur due to the critical speed of the screw, so the running speed should be reduced appropriately. Generally, the speed should be reduced by 10~15% for every 100mm increase of the screw.

容许负载力矩表 N.m Allowable overhang

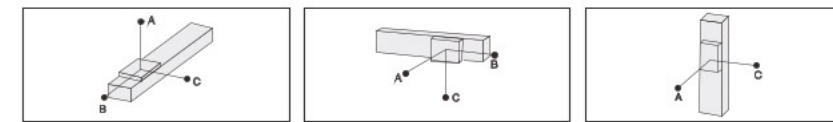

水平安装 Horizontal installation (单位Unit:mm)				侧面安装 Side mounting (单位Unit:mm)				垂直安装 Vertical installation (单位Unit:mm)			
导程 Lead	A	B	C	导程 Lead	A	B	C	导程 Lead	A	B	C
5	25kg	-	226	5	15kg	313	94	5	5kg	285	285
	30kg	-	103		21kg	154	-		10kg	129	166
	35kg	-	21		25kg	15	-		13kg	10	42
10	14kg	70	375	10	10kg	502	120	10	3kg	366	366
	21kg	35	217		16kg	189	71		6kg	141	141
	25kg	-	98		20kg	52	-		9kg	35	58
16	4kg	212	766	16	4kg	380	106	16	1kg	455	455
	9kg	109	401		9kg	198	31		2kg	212	212
	15kg	43	220		13kg	35	-		4kg	52	52
20	4kg	170	598	20	4kg	266	75	20	1kg	273	273
	7kg	77	321		7kg	139	22		2kg	127	127
	10kg	35	176		10kg	25	-		3kg	31	31

感应器连接图<原点及端点> Sensor layout

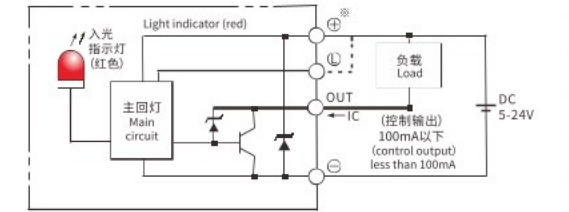

静态容许负载惯量 Static loading moment

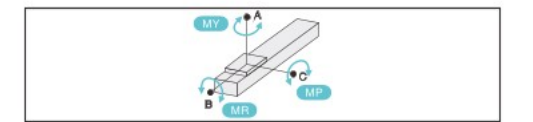

静态容许负载惯量 (单位Unit:N.m)	
MY	95
MP	95
MR	100

*力矩表所表示的数据, 代表重心。
The torque value in the chart indicate the center of gravity.

*符合型录规范的正常试用下, 保证寿命为10000公里。
Operation life is 10,000km when the product is using under the specified conditions.

*倒吊使用无法套用标准规范, 如有需求请咨询我司业务。
The standard specification cannot be applied to the use of inverted crane. Please consult our business if necessary.

搭配伺服马达一览表 Suitable motor brand

品牌 Brand	马达记号 Mark	刹车有无 Brake	马达容量 Motor capacity	电源电压 AC-Voltage	伺服马达型号 Servo motor model	驱动器型号 Driver Model
三菱 Mitsubishi	M	无刹车(水平式样) No brake (horizontal type)	200	220	HG-KR73	MR-J4-70A
松下 Panasonic	P	无刹车(水平式样) No brake (horizontal type)	200	220	MHMD082G1U	MBDHT3520
台达 Delta	T	无刹车(水平式样) No brake (horizontal type)	200	220	ECMA-C20807ES	ASD-B20721-B



电机外置直连/电机外置下方
Motor external direct connection/Motor external under below

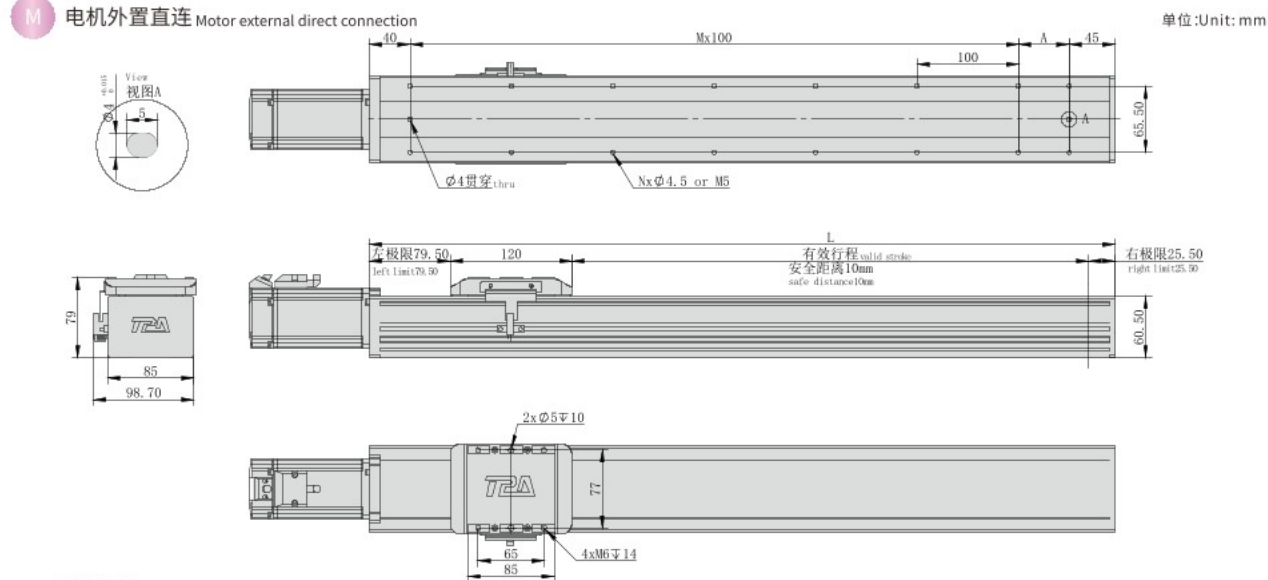

*不含电机重量。*Motor weight not included.

有效行程 Stroke	100	150	200	250	300	350	400	450	500	550	600	650	700	750	800	850	900	950	1000	1050
L	335	385	435	485	535	585	635	685	735	785	835	885	935	985	1035	1085	1135	1185	1235	1285
A	50	100	50	100	50	100	50	100	50	100	50	100	50	100	50	100	50	100	50	100
N	8	8	10	10	12	12	14	14	16	16	18	18	20	20	22	22	24	24	26	26
M	2	2	3	3	4	4	5	5	6	6	7	7	8	8	9	9	10	10	11	11
KG	2.7	3.1	3.5	3.9	4.3	4.7	5.1	5.5	5.9	6.3	6.7	7.1	7.5	7.9	8.3	8.7	9.1	9.5	9.9	10.3

如有超长行程及定制需求, 请咨询我司业务。If you have extra long trip and custom requirements, please consult our business.

电机外置左侧/电机外置右侧
Motor external left side / Motor external right side

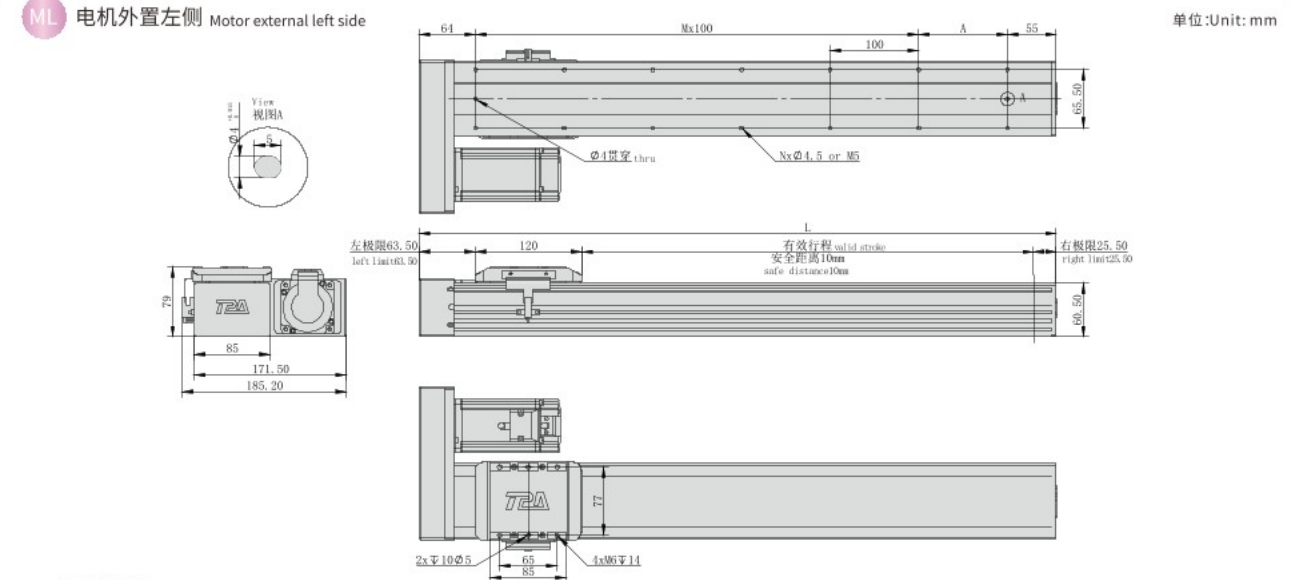

*不含电机重量。*Motor weight not included.

有效行程 Stroke	100	150	200	250	300	350	400	450	500	550	600	650	700	750	800	850	900	950	1000	1050
L	319	369	419	469	519	569	619	669	719	769	819	869	919	969	1019	1069	1119	1169	1219	1269
A	100	50	100	50	100	50	100	50	100	50	100	50	100	50	100	50	100	50	100	50
N	6	8	8	10	10	12	12	14	14	16	16	18	18	20	20	22	22	24	24	26
M	1	2	2	3	3	4	4	5	5	6	6	7	7	8	8	9	9	10	10	11
KG	2.5	2.9	3.3	3.7	4.1	4.5	4.9	5.3	5.7	6.1	6.5	6.9	7.3	7.7	8.1	8.5	8.9	9.3	9.7	10.1

如有超长行程及定制需求, 请咨询我司业务。If you have extra long trip and custom requirements, please consult our business.

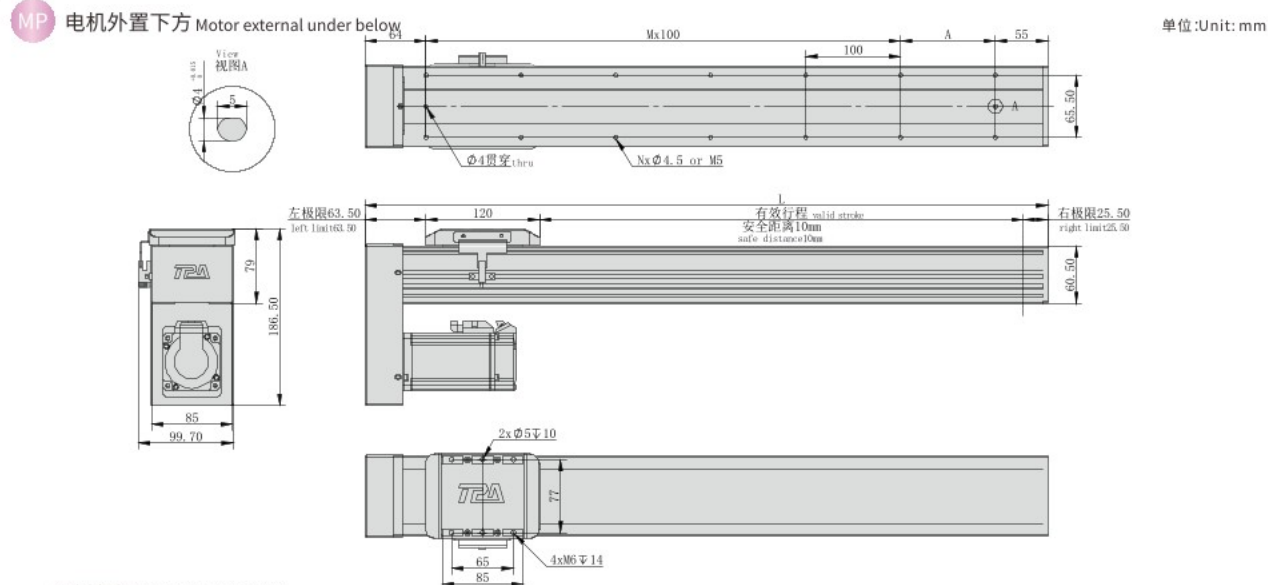

*不含电机重量。*Motor weight not included.

有效行程 Stroke	100	150	200	250	300	350	400	450	500	550	600	650	700	750	800	850	900	950	1000	1050
L	319	369	419	469	519	569	619	669	719	769	819	869	919	969	1019	1069	1119	1169	1219	1269
A	100	50	100	50	100	50	100	50	100	50	100	50	100	50	100	50	100	50	100	50
N	6	8	8	10	10	12	12	14	14	16	16	18	18	20	20	22	22	24	24	26
M	1	2	2	3	3	4	4	5	5	6	6	7	7	8	8	9	9	10	10	11
KG	2.5	2.9	3.3	3.7	4.1	4.5	4.9	5.3	5.7	6.1	6.5	6.9	7.3	7.7	8.1	8.5	8.9	9.3	9.7	10.1

如有超长行程及定制需求, 请咨询我司业务。If you have extra long trip and custom requirements, please consult our business.

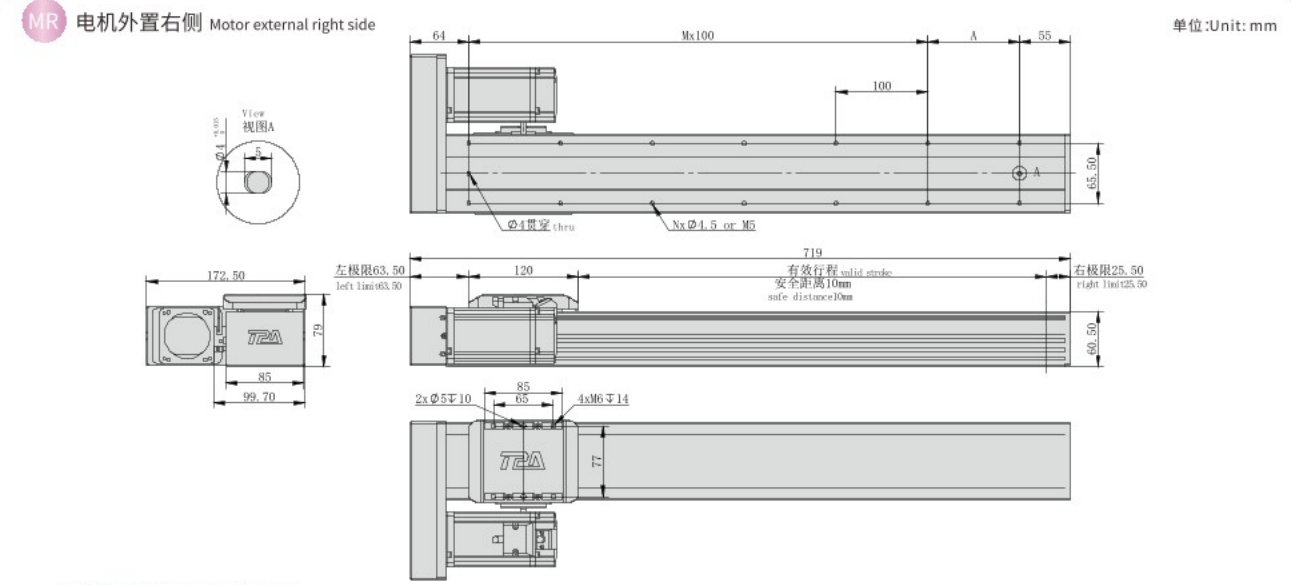

*不含电机重量。*Motor weight not included.

有效行程 Stroke	100	150	200	250	300	350	400	450	500	550	600	650	700	750	800	850	900	950	1000	1050
L	319	369	419	469	519	569	619	669	719	769	819	869	919	969	1019	1069	1119	1169	1219	1269
A	100	50	100	50	100	50	100	50	100	50	100	50	100	50	100	50	100	50	100	50
N	6	8	8	10	10	12	12	14	14	16	16	18	18	20	20	22	22	24	24	26
M	1	2	2	3	3	4	4	5	5	6	6	7	7	8	8	9	9	10	10	11
KG	2.5	2.9	3.3	3.7	4.1	4.5	4.9	5.3	5.7	6.1	6.5	6.9	7.3	7.7	8.1	8.5	8.9	9.3	9.7	10.1

如有超长行程及定制需求, 请咨询我司业务。If you have extra long trip and custom requirements, please consult our business.

- HNR
- HCR
- HNB
- HCB
- HNT
- XYZ
- ONB
- OCB
- GCR
- GCB
- GCBS
- GCRS
- ESR
- EMR
- EHR
- KSR
- LNP
- DDR

参考资料
Reference data



重复精度
Repeat Accuracy
±0.02
mm

此图仅供参考, 出货规格详见尺寸图面
This picture for reference only, specs details according with the drawing.

- 最大行程 Max stroke: 1200mm
- 最高速度 Max speed: 1000mm/s
- 马达容量 Motor output: 200W
- 滚珠螺杆 Ball screw: Ø16mm
- 直线滑轨 Linear guide: 15X12.5-2支

型号表达方式 Ordering method

TPA-HCR-105D-1610C-L1200-M-Y-P20-N3-F

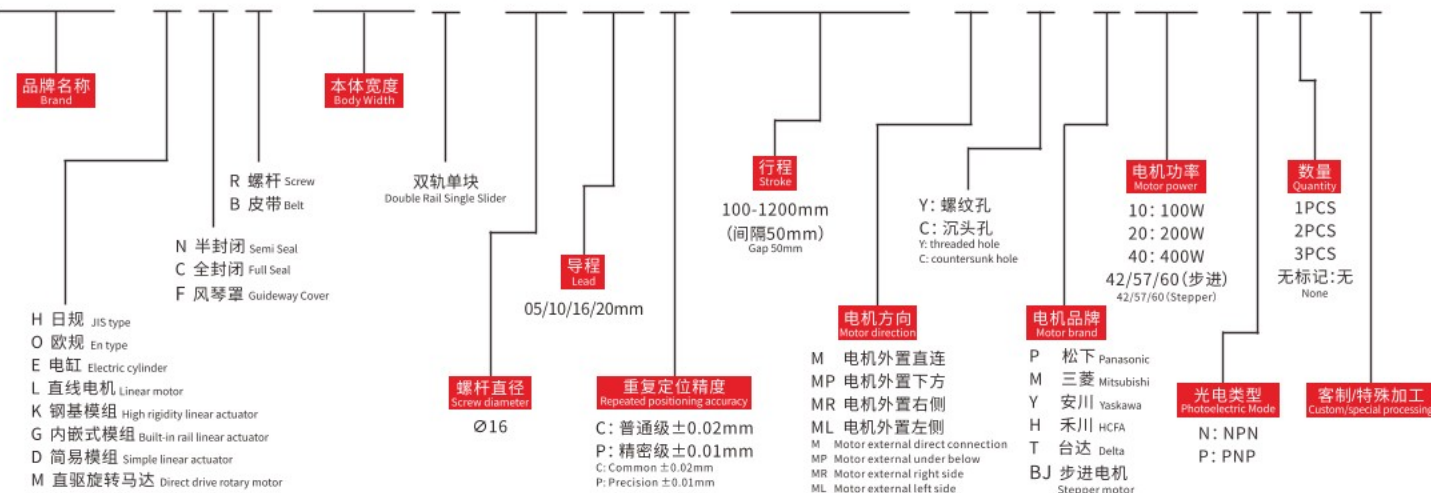

产品性能参数如下 Product performance parameters are as follows

电机功率 (W) Motor power (W)	200				
额定扭矩 (N.M) Rated torque (N.M)	0.64				
重复定位精度 (mm) Repeated positioning accuracy (mm)	±0.02				
导程 (mm) Lead (mm)	5	10	16	20	
最高速度 (mm/s) Maximum speed (mm/s)	250	500	800	1000	
电机额定转速 (RPM) Rated speed of motor (RPM)	3000				
最大可搬重量 Maximum Payload	水平使用 (kg) Horizontal (kg)	50	25	19	13
	垂直使用 (kg) Vertical (kg)	22	11	8	6
定格推力 (N) Rated thrust (N)	615	307	192	154	
标准行程 (mm) Stroke pitch (mm)	100~1200mm/50 间隔 50 mm Pitch				
滚珠螺杆外径 (mm) Ball screw Ø (mm)	Ø16				
基座材质 Material of base	硬质挤压铝材A1 Hard extruded aluminum A1				
安装面精度要求 (mm) Accuracy requirements of installation surface (mm)	C级<0.05; P级<0.02 C level<0.05 P level<0.02				
使用环境 Operating environment	0~40°C, 85%RH (无凝结) No condensation				

注1: 使用非上述功率电机时请依据实际参数推算。
Note 1: When using a motor with a power other than the above, please calculate according to the actual parameters.

注2: 最高速度因行程和负载而异, 当螺杆细长比大于1:50时, 可能会因螺杆临界速度产生共振和抖动, 应适当下调运行速度, 一般螺杆每增长100mm, 速度应下调10~15%。
Note 2: The maximum speed varies with stroke and load. When the screw slenderness ratio is greater than 1:50, resonance and jitter may occur due to the critical speed of the screw, so the running speed should be reduced appropriately. Generally, the speed should be reduced by 10~15% for every 100mm increase of the screw.

容许负载力矩表 N.m Allowable overhang

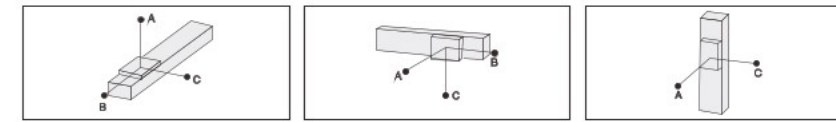

水平安装 Horizontal installation (单位Unit:mm)				侧面安装 Side mounting (单位Unit:mm)				垂直安装 Vertical installation (单位Unit:mm)				
导程 Lead	A	B	C	导程 Lead	A	B	C	导程 Lead	A	B	C	
5	30kg	21	32	262	10kg	602	187	153	5	10kg	93	106
	50kg	1	2	48	20kg	380	92	75		13kg	42	71
	60kg	-	-	-	30kg	9	-	-	10	15kg	23	41
10	20kg	93	162	260	10kg	545	122	109		3kg	333	368
	25kg	61	80	217	20kg	210	33	21		6kg	154	177
	30kg	32	45	175	30kg	-	-	-	10	9kg	100	118
16	10kg	155	242	425	5kg	477	140	123		3kg	413	262
	15kg	89	162	313	10kg	269	78	69		5kg	214	242
	20kg	40	88	199	15kg	126	54	37	16	8kg	60	85
20	5kg	385	407	629	3kg	462	228	179		1kg	546	570
	10kg	110	179	381	7kg	289	94	76		3kg	375	391
	20kg	63	98	230	10kg	211	55	39	20	5kg	123	150

传感器连接图<原点及端点> Sensor layout

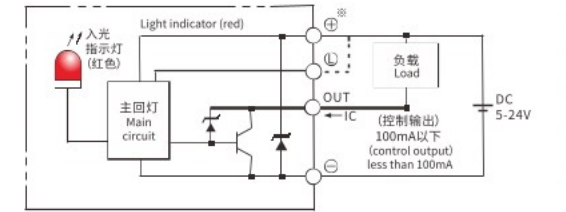

- HNR
- HCR
- HNB
- HCB
- HNT
- XYZ
- ONB
- OCB
- GCR
- GCB
- GCBS
- GCRS
- ESR
- EMR
- EHR
- KSR
- LNP
- DDR
- 参考资料 Reference data

静态容许负载惯量 Static loading moment

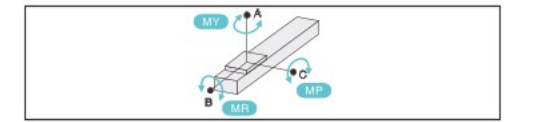

点 (Point)	惯量 (Inertia) (单位Unit:N.m)
MY	150
MP	150
MR	130

*力矩表所表示的数据, 代表重心。
The torque value in the chart indicate the center of gravity.

*符合型录规范的正常试用下, 保证寿命为10000公里。
Operation life is 10,000km when the product is using under the specified conditions.

*倒吊使用无法套用标准规范, 如有需求请咨询我司业务。
The standard specification cannot be applied to the use of inverted crane. Please consult our business if necessary.

搭配伺服马达一览表 Suitable motor brand

品牌 Brand	马达记号 Mark	刹车有无 Brake	马达容量 Motor capacity	电源电压 AC-Voltage	伺服马达型号 Servo motor model	驱动器型号 Driver Model
三菱 Mitsubishi	M	无刹车(水平式样) No brake (horizontal type)	200	220	HG-KR73	MR-J4-70A
松下 Panasonic	P	无刹车(水平式样) No brake (horizontal type)	200	220	MHMD082G1U	MBDHT3520
台达 Delta	T	无刹车(水平式样) No brake (horizontal type)	200	220	ECMA-C20807ES	ASD-B20721-B



电机外置直连/电机外置下方
Motor external direct connection/Motor external under below

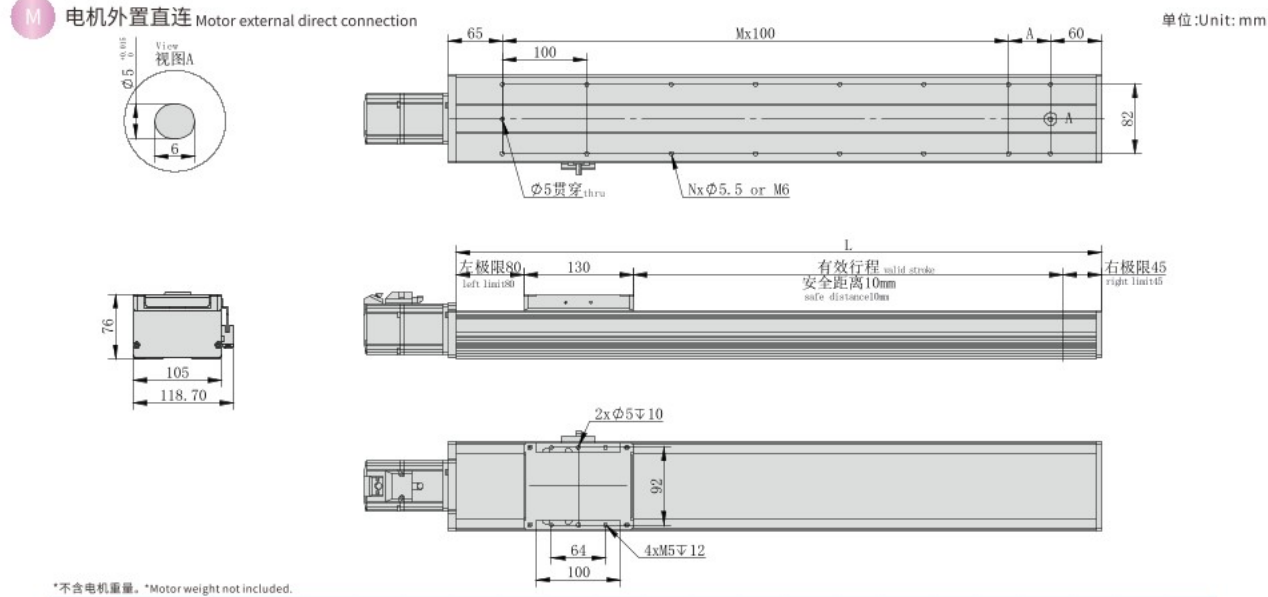

*不含电机重量。*Motor weight not included.

有效行程 Stroke	100	150	200	250	300	350	400	450	500	550	600	650	700	750	800	850	900	950	1000	1050	1100	1150	1200
L	375	425	475	525	575	625	675	725	775	825	875	925	975	1025	1075	1125	1175	1225	1275	1325	1375	1425	1475
A	50	100	50	100	50	100	50	100	50	100	50	100	50	100	50	100	50	100	50	100	50	100	50
N	8	8	10	10	12	12	14	14	16	16	18	18	20	20	22	22	24	24	26	26	28	28	30
M	2	3	3	4	4	5	5	6	6	7	7	8	8	9	9	10	10	11	11	12	12	13	13
KG	3.5	3.8	4.1	4.4	4.7	5	5.3	5.6	5.9	6.2	6.5	6.8	7.1	7.4	7.7	8	8.3	8.6	8.9	9.2	9.5	9.8	10.1

如有超长行程及定制需求, 请咨询我司业务。If you have extra long trip and custom requirements, please consult our business.

电机外置左侧/电机外置右侧
Motor external left side / Motor external right side

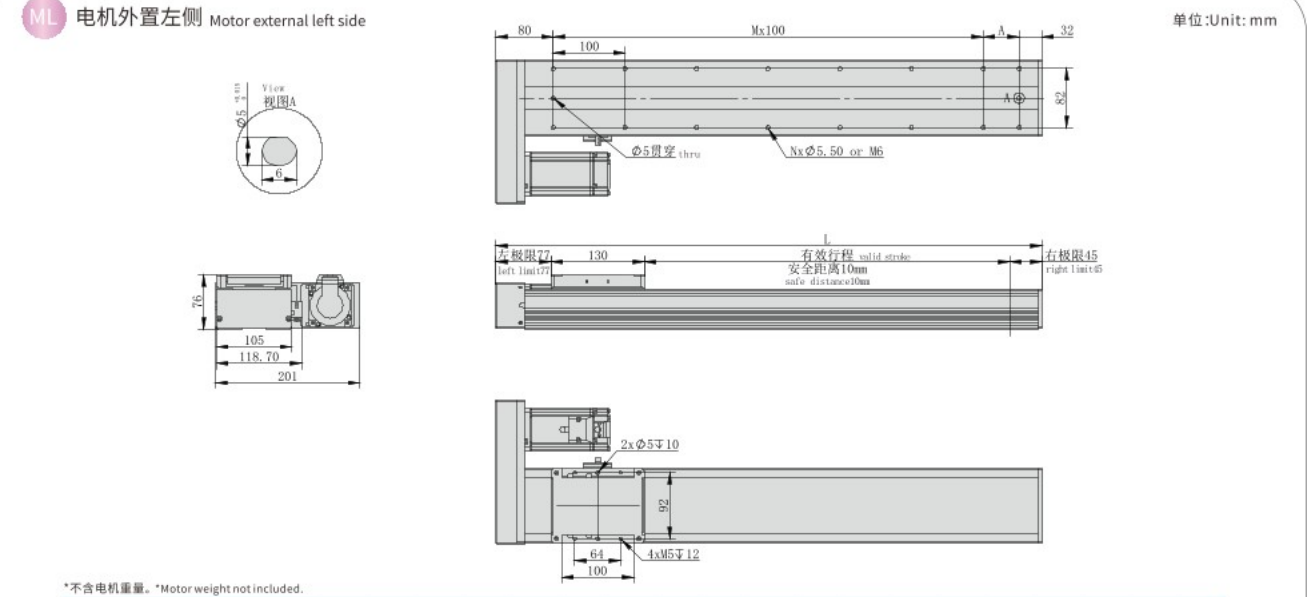

*不含电机重量。*Motor weight not included.

有效行程 Stroke	100	150	200	250	300	350	400	450	500	550	600	650	700	750	800	850	900	950	1000	1050	1100	1150	1200
L	362	412	462	512	562	612	662	712	762	812	862	912	962	1012	1062	1112	1162	1212	1262	1312	1362	1412	1462
A	50	100	50	100	50	100	50	100	50	100	50	100	50	100	50	100	50	100	50	100	50	100	50
N	8	8	10	10	12	12	14	14	16	16	18	18	20	20	22	22	24	24	26	26	28	28	30
M	2	3	3	4	4	5	5	6	6	7	7	8	8	9	9	10	10	11	11	12	12	13	13
KG	3.5	3.8	4.1	4.4	4.7	5	5.3	5.6	5.9	6.2	6.5	6.8	7.1	7.4	7.7	8	8.3	8.6	8.9	9.2	9.5	9.8	10.1

如有超长行程及定制需求, 请咨询我司业务。If you have extra long trip and custom requirements, please consult our business.

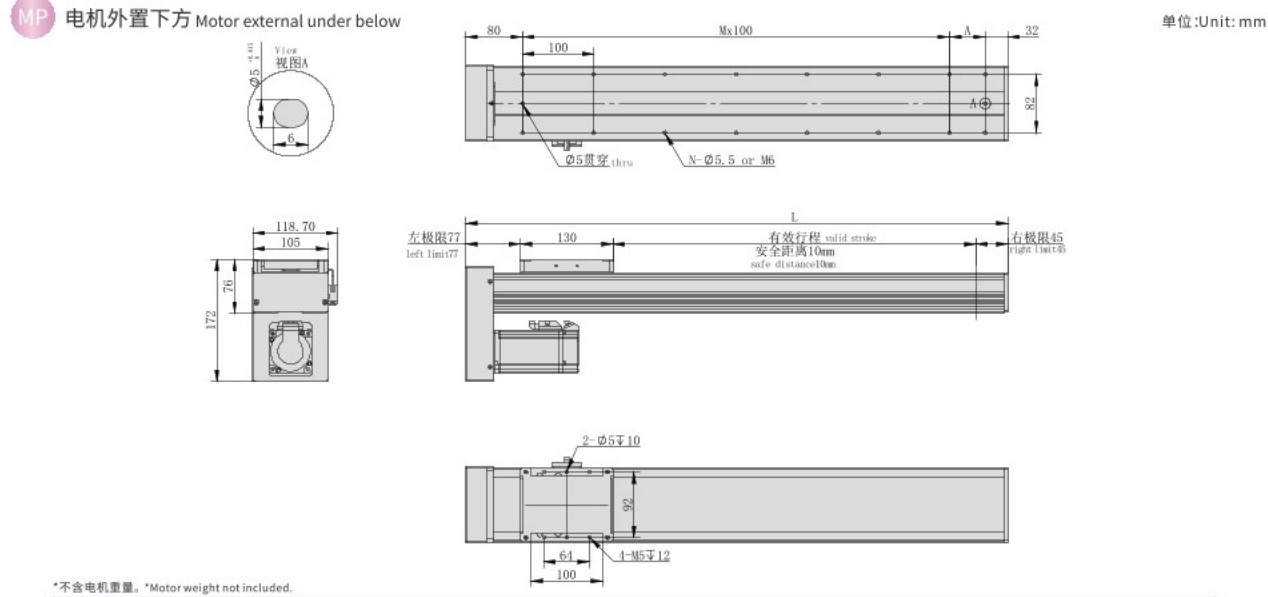

*不含电机重量。*Motor weight not included.

有效行程 Stroke	100	150	200	250	300	350	400	450	500	550	600	650	700	750	800	850	900	950	1000	1050	1100	1150	1200
L	362	412	462	512	562	612	662	712	762	812	862	912	962	1012	1062	1112	1162	1212	1262	1312	1362	1412	1462
A	50	100	50	100	50	100	50	100	50	100	50	100	50	100	50	100	50	100	50	100	50	100	50
N	8	8	10	10	12	12	14	14	16	16	18	18	20	20	22	22	24	24	26	26	28	28	30
M	2	3	3	4	4	5	5	6	6	7	7	8	8	9	9	10	10	11	11	12	12	13	13
KG	3.5	3.8	4.1	4.4	4.7	5	5.3	5.6	5.9	6.2	6.5	6.8	7.1	7.4	7.7	8	8.3	8.6	8.9	9.2	9.5	9.8	10.1

如有超长行程及定制需求, 请咨询我司业务。If you have extra long trip and custom requirements, please consult our business.

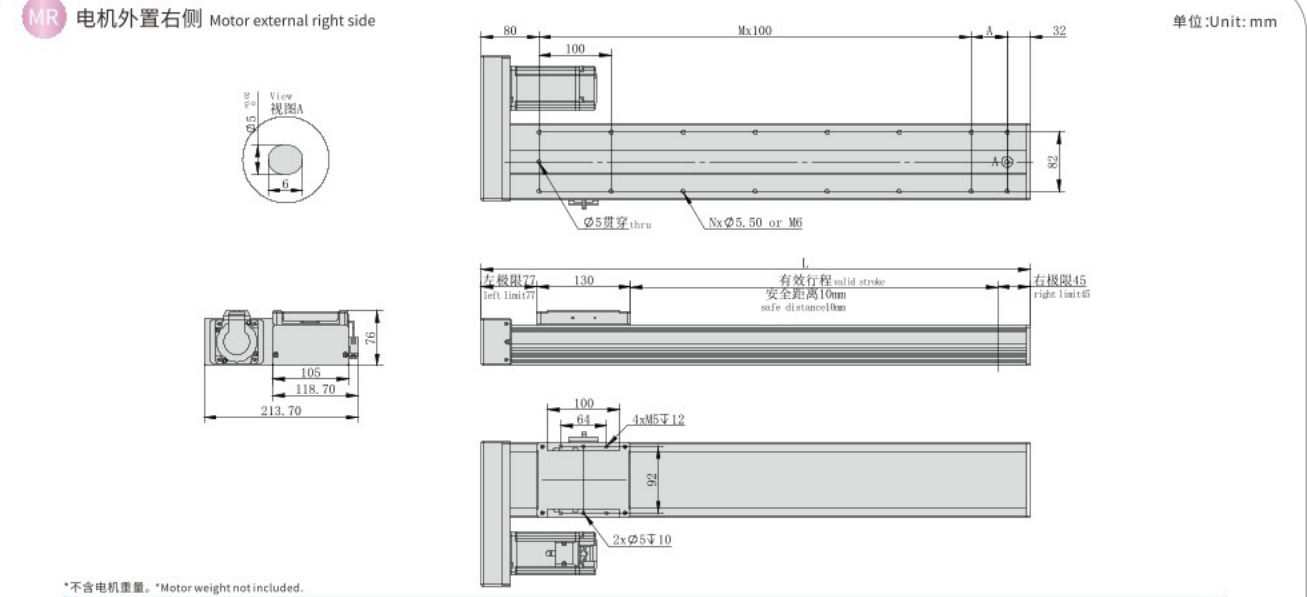

*不含电机重量。*Motor weight not included.

有效行程 Stroke	100	150	200	250	300	350	400	450	500	550	600	650	700	750	800	850	900	950	1000	1050	1100	1150	1200
L	362	412	462	512	562	612	662	712	762	812	862	912	962	1012	1062	1112	1162	1212	1262	1312	1362	1412	1462
A	50	100	50	100	50	100	50	100	50	100	50	100	50	100	50	100	50	100	50	100	50	100	50
N	8	8	10	10	12	12	14	14	16	16	18	18	20	20	22	22	24	24	26	26	28	28	30
M	2	3	3	4	4	5	5	6	6	7	7	8	8	9	9	10	10	11	11	12	12	13	13
KG	3.5	3.8	4.1	4.4	4.7	5	5.3	5.6	5.9	6.2	6.5	6.8	7.1	7.4	7.7	8	8.3	8.6	8.9	9.2	9.5	9.8	10.1

如有超长行程及定制需求, 请咨询我司业务。If you have extra long trip and custom requirements, please consult our business.

- HNR
- HCR
- HNB
- HCB
- HNT
- XYZ
- ONB
- OCB
- GCR
- GCB
- GCBS
- GCRS
- ESR
- EMR
- EHR
- KSR
- LNP
- DDR

参考资料
Reference data



重复精度
Repeat Accuracy
±0.02
mm

此图仅供参考, 出货规格详见尺寸图面
This picture for reference only, specs details according with the drawing.

- 最大行程 Max stroke: 1200mm
- 最高速度 Max speed: 1000mm/s
- 马达容量 Motor output: 200W
- 滚珠螺杆 Ball screw: Ø16mm
- 直线滑轨 Linear guide: 12X8-2支

型号表达方式 Ordering method

TPA-HCR-110D-1610C-L1200-M-Y-P20-N3-F

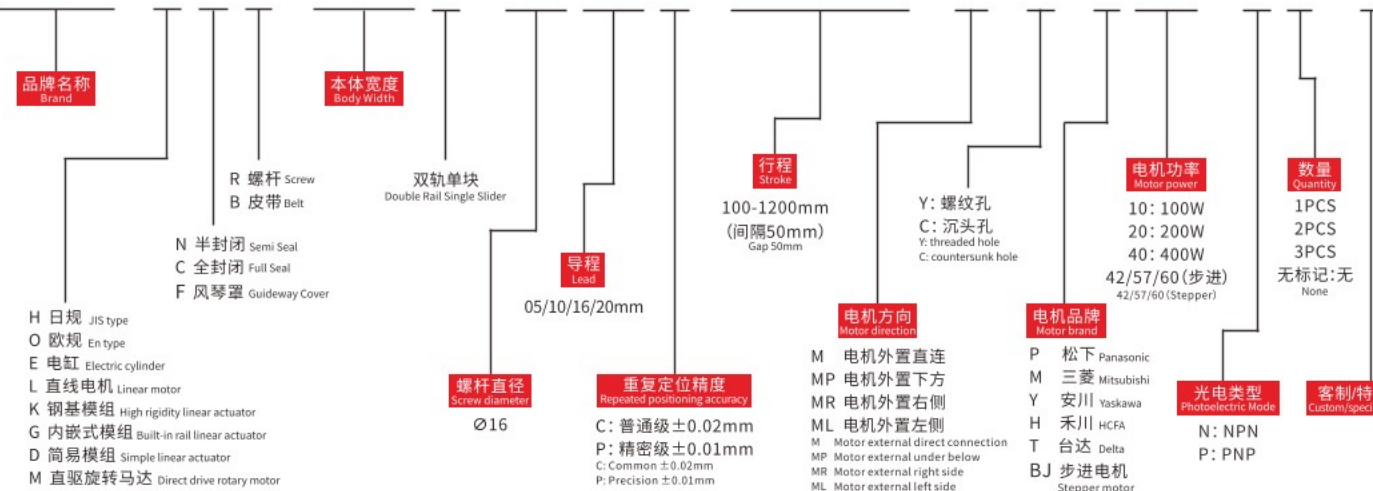

产品性能参数如下 Product performance parameters are as follows

电机功率 (W) Motor power (W)	200				
额定扭矩 (N.M) Rated torque (N.M)	0.64				
重复定位精度 (mm) Repeated positioning accuracy (mm)	±0.02				
导程 (mm) Lead (mm)	5	10	16	20	
最高速度 (mm/s) Maximum speed (mm/s)	250	500	800	1000	
电机额定转速 (RPM) Rated speed of motor (RPM)	3000				
最大可搬重量 Maximum Payload	水平使用 (kg) Horizontal (kg)	50	25	19	13
	垂直使用 (kg) Vertical (kg)	22	11	8	6
定格推力 (N) Rated thrust (N)	615	307	192	154	
标准行程 (mm) Stroke pitch (mm)	100~1200mm/50 间隔 50 mm Pitch				
滚珠螺杆外径 (mm) Ball screw Ø (mm)	Ø16				
基座材质 Material of base	硬质挤压铝材A1 Hard extruded aluminum A1				
安装面精度要求 (mm) Accuracy requirements of installation surface (mm)	C级<0.05; P级<0.02 C level<0.05 P level<0.02				
使用环境 Operating environment	0~40°C, 85%RH (无凝结) No condensation				

注1: 使用非上述功率电机时请依据实际参数推算。
Note 1: When using a motor with a power other than the above, please calculate according to the actual parameters.
注2: 最高速度因行程和负载而异, 当螺杆细长比大于1:50时, 可能会因螺杆临界速度产生共振和抖动, 应适当下调运行速度, 一般螺杆每增长100mm, 速度应下调10~15%。
Note 2: The maximum speed varies with stroke and load. When the screw slenderness ratio is greater than 1:50, resonance and jitter may occur due to the critical speed of the screw, so the running speed should be reduced appropriately. Generally, the speed should be reduced by 10~15% for every 100mm increase of the screw.

传感器连接图<原点及端点> Sensor layout

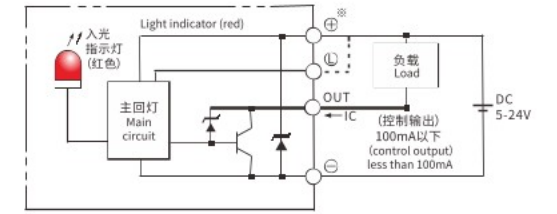

容许负载力矩表 N.m Allowable overhang

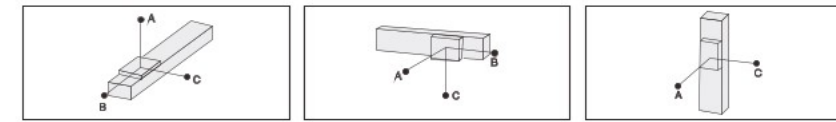

水平安装 Horizontal installation (单位Unit:mm)				侧面安装 Side mounting (单位Unit:mm)				垂直安装 Vertical installation (单位Unit:mm)			
导程 Lead	A	B	C	导程 Lead	A	B	C	导程 Lead	A	B	C
5	30kg	15	35	399	10kg	1385	37	95	10kg	132	99
	50kg	-	-	-	20kg	495	-	19	13kg	100	72
	60kg	-	-	-	30kg	-	-	-	15kg	79	39
10	20kg	57	68	323	10kg	495	29	86	6kg	208	164
	25kg	23	51	205	20kg	209	-	11	8kg	96	58
	35kg	-	-	100	30kg	-	-	-	10kg	42	7
16	10kg	160	177	567	5kg	610	100	143	3kg	245	189
	15kg	82	109	350	10kg	371	82	113	5kg	180	153
	23kg	-	-	116	20kg	168	-	21	7kg	52	10
20	5kg	188	210	872	5kg	575	102	140	1kg	478	438
	10kg	89	108	441	10kg	308	65	88	2kg	199	111
	18kg	55	60	260	20kg	122	-	3	4kg	148	96

静态容许负载惯量 Static loading moment

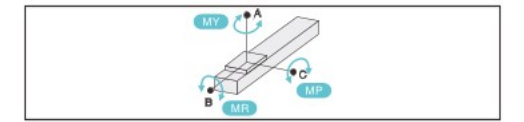

静态容许负载惯量 (单位Unit:N.m)	
MY	110
MP	110
MR	120

*力矩表所表示的数据, 代表重心。
The torque value in the chart indicate the center of gravity.
*符合型录规范的正常试用下, 保证寿命为10000公里。
Operation life is 10,000km when the product is using under the specified conditions.
*倒吊使用无法套用标准规范, 如有需求请咨询我司业务。
The standard specification cannot be applied to the use of inverted crane. Please consult our business if necessary.

搭配伺服马达一览表 Suitable motor brand

品牌 Brand	马达记号 Mark	刹车有无 Brake	马达容量 Motor capacity	电源电压 AC-Voltage	伺服马达型号 Servo motor model	驱动器型号 Driver Model
三菱 Mitsubishi	M	无刹车(水平式样) No brake (horizontal type)	200	220	HG-KR73	MR-J4-70A
松下 Panasonic	P	无刹车(水平式样) No brake (horizontal type)	200	220	MHMD082G1U	MBDHT3520
台达 Delta	T	无刹车(水平式样) No brake (horizontal type)	200	220	ECMA-C20807ES	ASD-B20721-B



电机外置直连/电机外置下方
Motor external direct connection/Motor external under below

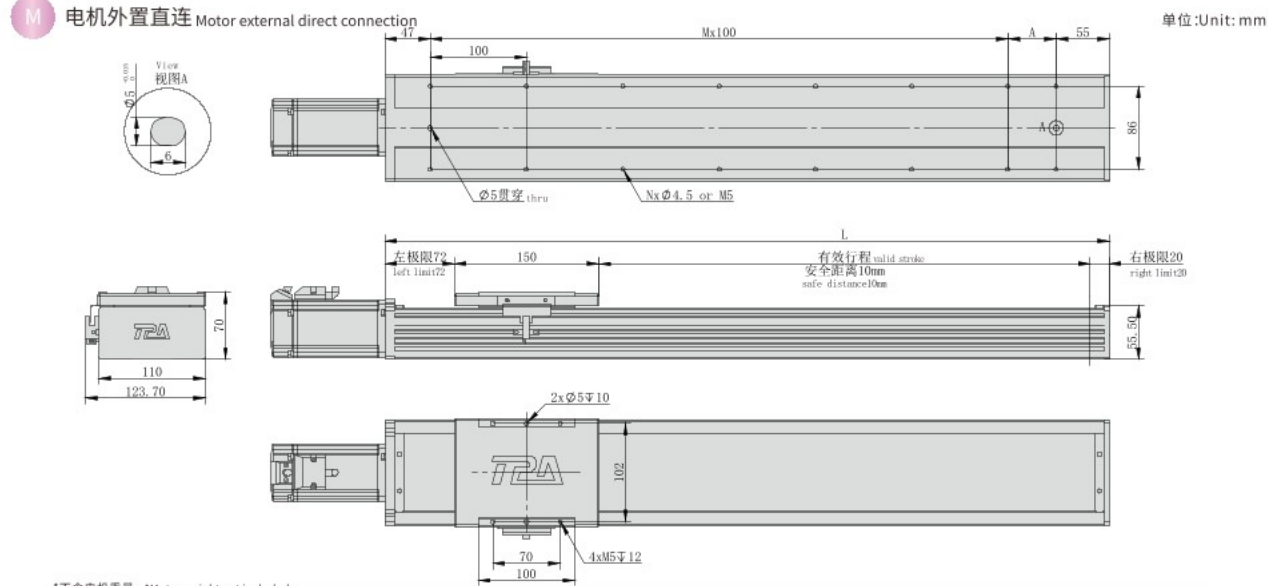

*不含电机重量。*Motor weight not included.

有效行程 Stroke	100	150	200	250	300	350	400	450	500	550	600	650	700	750	800	850	900	950	1000	1050	1100	1150	1200
L	352	402	452	502	552	602	652	702	752	802	852	902	952	1002	1052	1102	1152	1202	1252	1302	1352	1402	1452
A	50	100	50	100	50	100	50	100	50	100	50	100	50	100	50	100	50	100	50	100	50	100	50
N	8	8	10	10	12	12	14	14	16	16	18	18	20	20	22	22	24	24	26	26	28	28	30
M	2	2	3	3	4	4	5	5	6	6	7	7	8	8	9	9	10	10	11	11	12	12	13
KG	5.2	5.7	6.2	6.7	7.2	7.7	8.2	8.7	9.2	9.7	10.2	10.7	11.2	11.7	12.2	12.7	13.2	13.7	14.2	14.7	15.2	15.7	16.2

如有超长行程及定制需求, 请咨询我司业务。If you have extra long trip and custom requirements, please consult our business.

电机外置左侧/电机外置右侧
Motor external left side / Motor external right side

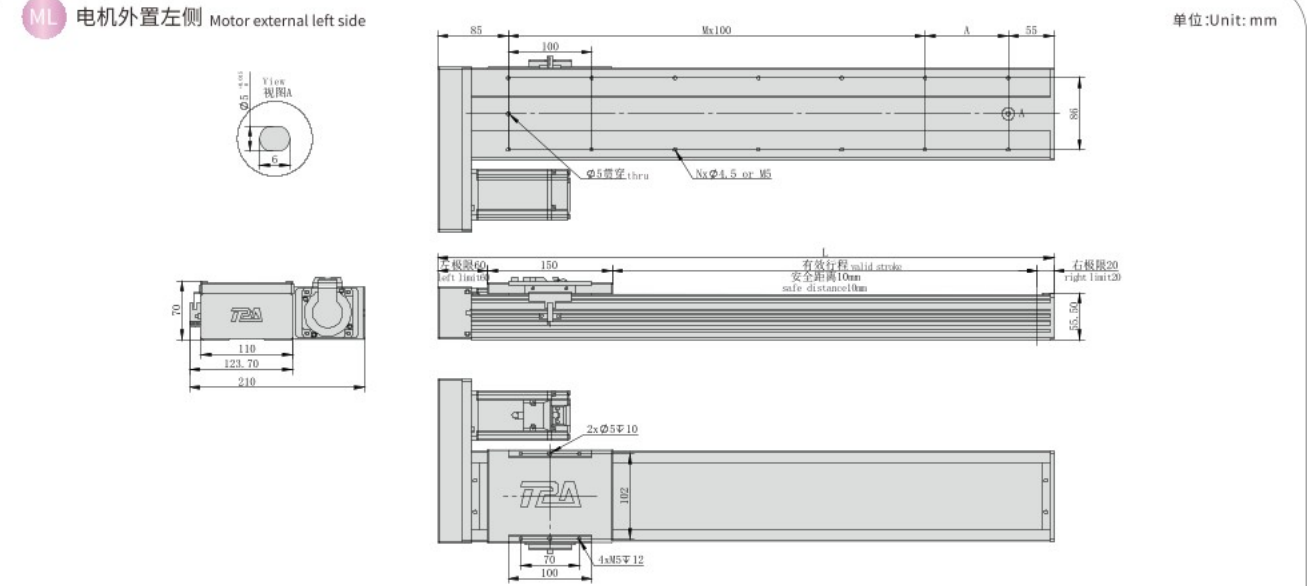

*不含电机重量。*Motor weight not included.

有效行程 Stroke	100	150	200	250	300	350	400	450	500	550	600	650	700	750	800	850	900	950	1000	1050	1100	1150	1200
L	340	390	440	490	540	590	640	690	740	790	840	890	940	990	1040	1090	1140	1190	1240	1290	1340	1390	1440
A	100	50	100	50	100	50	100	50	100	50	100	50	100	50	100	50	100	50	100	50	100	50	100
N	6	8	8	10	10	12	12	14	14	16	16	18	18	20	20	22	22	24	24	26	26	28	28
M	1	2	2	3	3	4	4	5	5	6	6	7	7	8	8	9	9	10	10	11	11	12	12
KG	5.5	6	6.5	7	7.5	8	8.5	9	9.5	10	10.5	11	11.5	12	12.5	13	13.5	14	14.5	15	15.5	16	16.5

如有超长行程及定制需求, 请咨询我司业务。If you have extra long trip and custom requirements, please consult our business.

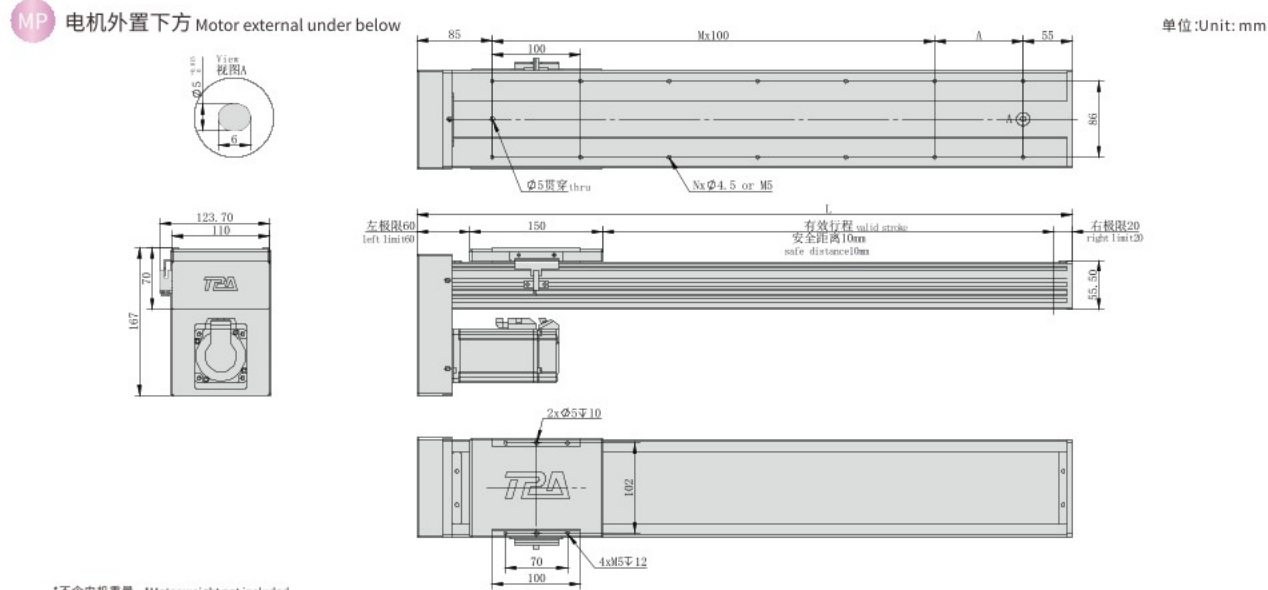

*不含电机重量。*Motor weight not included.

有效行程 Stroke	100	150	200	250	300	350	400	450	500	550	600	650	700	750	800	850	900	950	1000	1050	1100	1150	1200
L	340	390	440	490	540	590	640	690	740	790	840	890	940	990	1040	1090	1140	1190	1240	1290	1340	1390	1440
A	100	50	100	50	100	50	100	50	100	50	100	50	100	50	100	50	100	50	100	50	100	50	100
N	6	8	8	10	10	12	12	14	14	16	16	18	18	20	20	22	22	24	24	26	26	28	28
M	1	2	2	3	3	4	4	5	5	6	6	7	7	8	8	9	9	10	10	11	11	12	12
KG	5.5	6	6.5	7	7.5	8	8.5	9	9.5	10	10.5	11	11.5	12	12.5	13	13.5	14	14.5	15	15.5	16	16.5

如有超长行程及定制需求, 请咨询我司业务。If you have extra long trip and custom requirements, please consult our business.

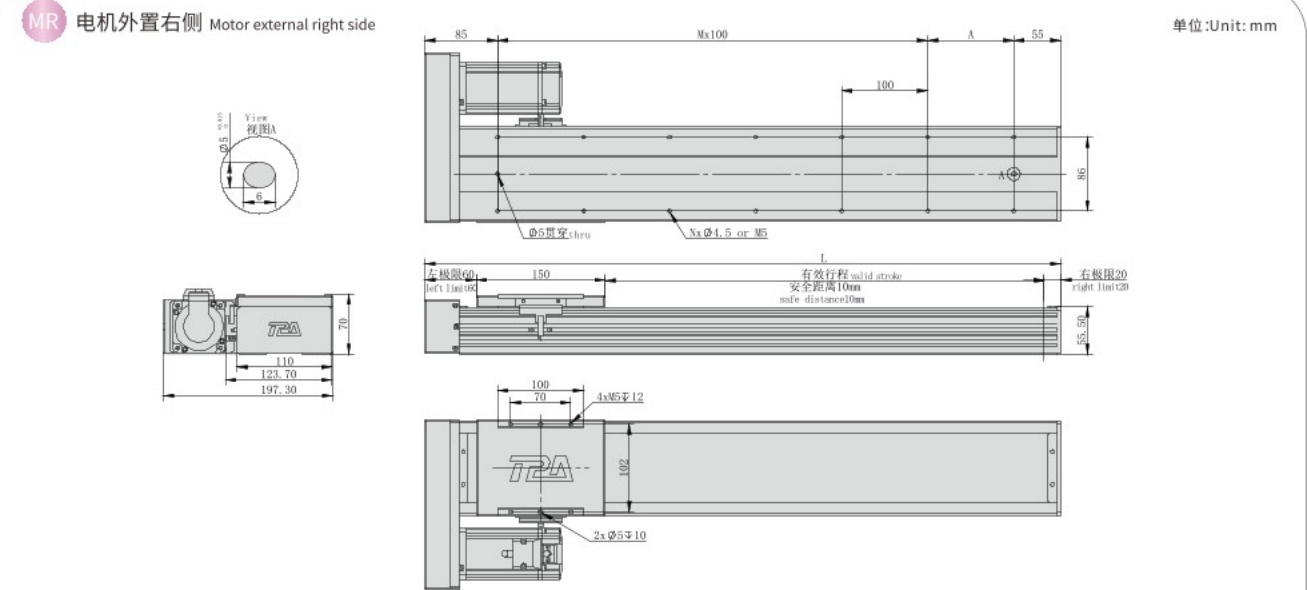

*不含电机重量。*Motor weight not included.

有效行程 Stroke	100	150	200	250	300	350	400	450	500	550	600	650	700	750	800	850	900	950	1000	1050	1100	1150	1200
L	340	390	440	490	540	590	640	690	740	790	840	890	940	990	1040	1090	1140	1190	1240	1290	1340	1390	1440
A	100	50	100	50	100	50	100	50	100	50	100	50	100	50	100	50	100	50	100	50	100	50	100
N	6	8	8	10	10	12	12	14	14	16	16	18	18	20	20	22	22	24	24	26	26	28	28
M	1	2	2	3	3	4	4	5	5	6	6	7	7	8	8	9	9	10	10	11	11	12	12
KG	5.5	6	6.5	7	7.5	8	8.5	9	9.5	10	10.5	11	11.5	12	12.5	13	13.5	14	14.5	15	15.5	16	16.5

如有超长行程及定制需求, 请咨询我司业务。If you have extra long trip and custom requirements, please consult our business.

- HNR
- HCR
- HNB
- HCB
- HNT
- XYZ
- ONB
- OCB
- GCR
- GCB
- GCBS
- GCRS
- ESR
- EMR
- EHR
- KSR
- LNP
- DDR

参考资料
Reference data



重复精度
Repeat Accuracy
±0.02
mm

此图仅供参考, 出货规格详见尺寸图面
This picture for reference only, specs details according with the drawing.

- 最大行程 Max stroke: 1200mm
- 最高速度 Max speed: 1000mm/s
- 马达容量 Motor output: 200W
- 滚珠螺杆 Ball screw: Ø16mm
- 直线滑轨 Linear guide: 15X12.5-2支

型号表达方式 Ordering method

TPA-HCR-120D-1610C-L1200-M-Y-P20-N3-F

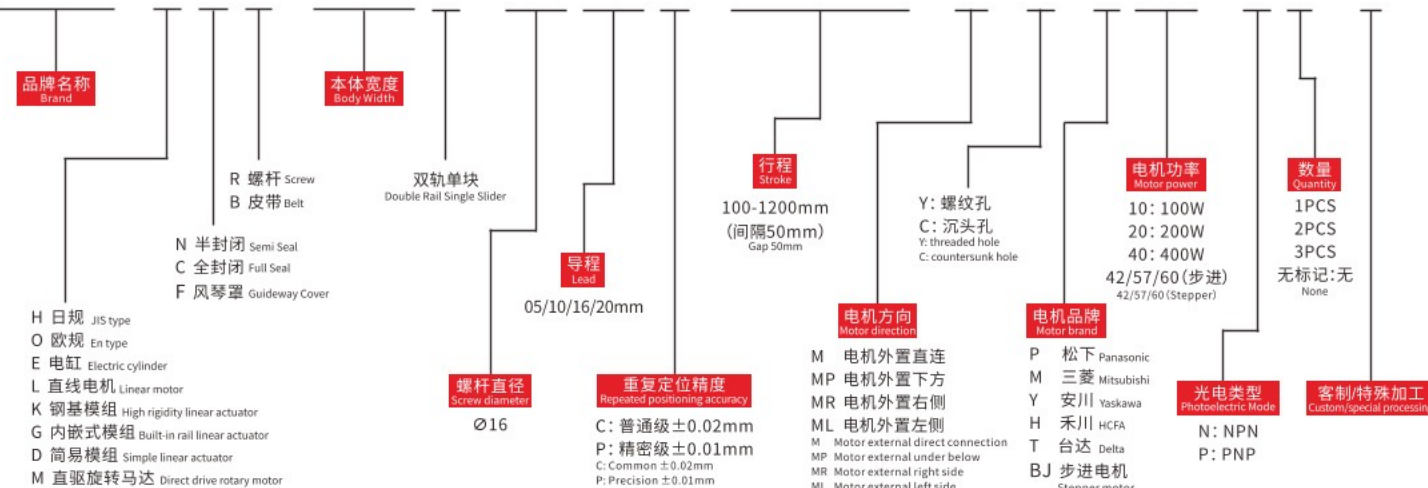

产品性能参数如下 Product performance parameters are as follows

电机功率 (W) Motor power (W)	200				
额定扭矩 (N.M) Rated torque (N.M)	0.64				
重复定位精度 (mm) Repeated positioning accuracy (mm)	±0.02				
导程 (mm) Lead (mm)	5	10	16	20	
最高速度 (mm/s) Maximum speed (mm/s)	250	500	800	1000	
电机额定转速 (RPM) Rated speed of motor (RPM)	3000				
最大可搬重量 Maximum Payload	水平使用 (kg) Horizontal (kg)	60	30	23	25
	垂直使用 (kg) Vertical (kg)	27	12	10	7
定格推力 (N) Rated thrust (N)	615	307	192	154	
标准行程 (mm) Stroke pitch (mm)	100~1200mm/50 间隔 50 mm Pitch				
滚珠螺杆外径 (mm) Ball screw Ø (mm)	Ø16				
基座材质 Material of base	硬质挤压铝材A1 Hard extruded aluminum A1				
安装面精度要求 (mm) Accuracy requirements of installation surface (mm)	C级<0.05; P级<0.02 C level<0.05 P level<0.02				
使用环境 Operating environment	0~40°C, 85%RH (无凝结) No condensation				

注1: 使用非上述功率电机时请依据实际参数推算。
Note 1: When using a motor with a power other than the above, please calculate according to the actual parameters.
注2: 最高速度因行程和负载而异, 当螺杆细长比大于1:50时, 可能会因螺杆临界速度产生共振和抖动, 应适当下调运行速度, 一般螺杆每增长100mm, 速度应下调10~15%。
Note 2: The maximum speed varies with stroke and load. When the screw slenderness ratio is greater than 1:50, resonance and jitter may occur due to the critical speed of the screw, so the running speed should be reduced appropriately. Generally, the speed should be reduced by 10~15% for every 100mm increase of the screw.

容许负载力矩表 N.m Allowable overhang

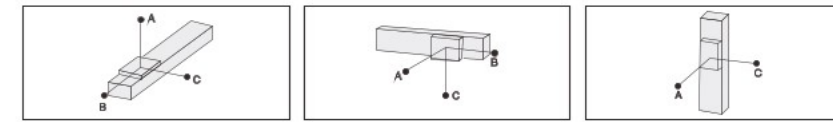

水平安装 Horizontal installation (单位Unit:mm)				侧面安装 Side mounting (单位Unit:mm)				垂直安装 Vertical installation (单位Unit:m)				
导程 Lead	A	B	C	导程 Lead	A	B	C	导程 Lead	A	C		
5	30kg	882	65	78	25kg	100	84	1102	5	5kg	544	544
	40kg	606	43	51	35kg	63	52	725		8kg	341	341
	50kg	437	29	35	50kg	35	29	433	10	12kg	227	227
10	15kg	875	138	157	10kg	250	221	1311		4kg	606	606
	25kg	485	73	83	20kg	110	97	633	10	8kg	303	303
	30kg	386	56	64	30kg	64	56	385	20	-	-	-
16	3kg	1644	888	770	2kg	1182	1364	2512		2kg	961	961
	5kg	984	510	448	5kg	448	510	976	20	3kg	639	639
	-	-	-	-	-	-	-	-		-	-	-
20	5kg	1160	384	386	5kg	317	316	955		-	-	-
	10kg	561	180	181	12kg	147	144	455		-	-	-
	18kg	288	88	89	18kg	89	88	288		-	-	-

感应器连接图<原点及端点> Sensor layout

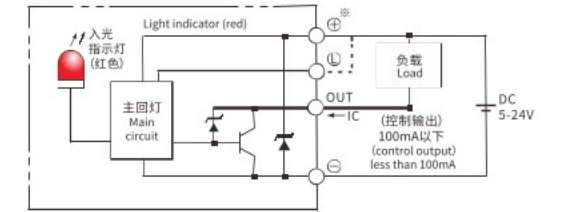

静态容许负载惯量 Static loading moment

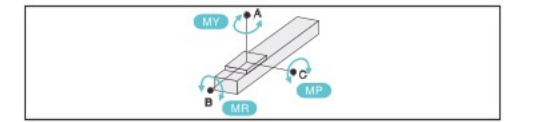

导程 Lead	MY	MP	MR
5	150	150	130

*力矩表所表示的数据, 代表重心。
The torque value in the chart indicate the center of gravity.
*符合型录规范的正常试用下, 保证寿命为10000公里。
Operation life is 10,000km when the product is using under the specified conditions.
*倒吊使用无法套用标准规范, 如有需求请咨询我司业务。
The standard specification cannot be applied to the use of inverted crane. Please consult our business if necessary.

搭配伺服马达一览表 Suitable motor brand

品牌 Brand	马达记号 Mark	刹车有无 Brake	马达容量 Motor capacity	电源电压 AC-Voltage	伺服马达型号 Servo motor model	驱动器型号 Driver Model
三菱 Mitsubishi	M	无刹车(水平式样) No brake (horizontal type)	200	220	HG-KR73	MR-J4-70A
松下 Panasonic	P	无刹车(水平式样) No brake (horizontal type)	200	220	MHMD082G1U	MBDHT3520
台达 Delta	T	无刹车(水平式样) No brake (horizontal type)	200	220	ECMA-C20807ES	ASD-B20721-B



电机外置直连/电机外置下方
Motor external direct connection/Motor external under below

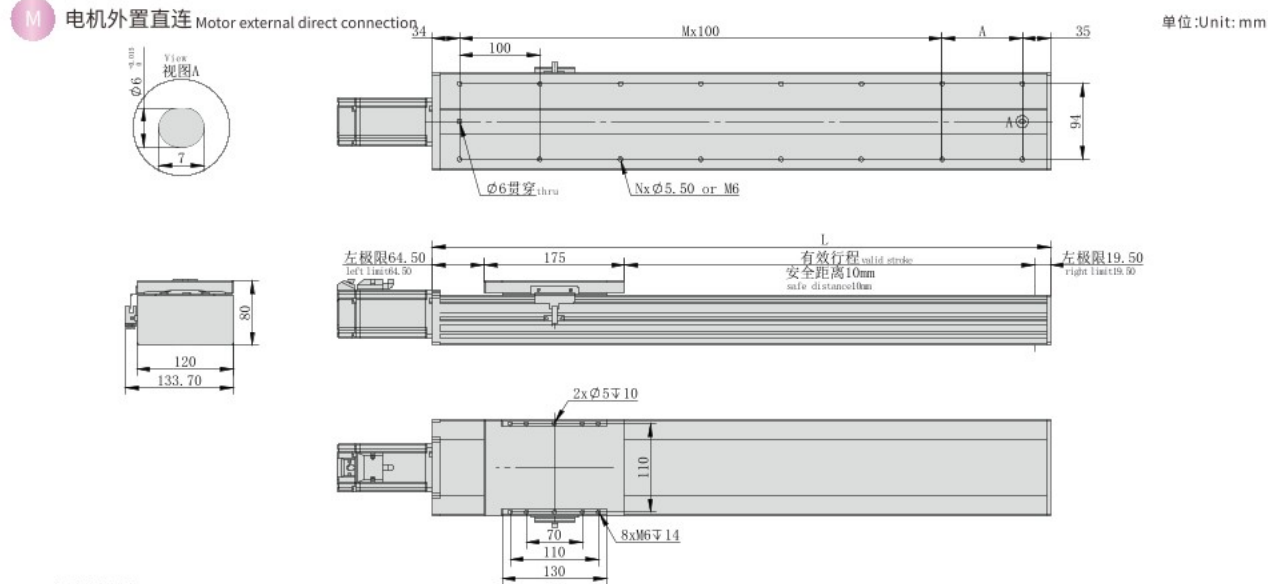

*不含电机重量。*Motor weight not included.

有效行程 Stroke	100	150	200	250	300	350	400	450	500	550	600	650	700	750	800	850	900	950	1000	1050	1100	1150	1200
L	369	419	469	519	569	619	669	719	769	819	869	919	969	1019	1069	1119	1169	1219	1269	1319	1369	1419	1469
A	100	50	100	50	100	50	100	50	100	50	100	50	100	50	100	50	100	50	100	50	100	50	100
N	8	10	10	12	12	14	14	16	16	18	18	20	20	22	22	24	24	26	26	28	28	30	30
M	2	3	3	4	4	5	5	6	6	7	7	8	8	9	9	10	10	11	11	12	12	13	13
KG	6.5	7.5	8.5	9.5	10.5	11.5	12.5	13.5	14.5	15.5	16.5	17.5	18.5	19.5	20.5	21.5	22.5	23.5	24.5	25.5	26.5	27.5	28.5

如有超长行程及定制需求, 请咨询我司业务。If you have extra long trip and custom requirements, please consult our business.

电机外置左侧/电机外置右侧
Motor external left side / Motor external right side

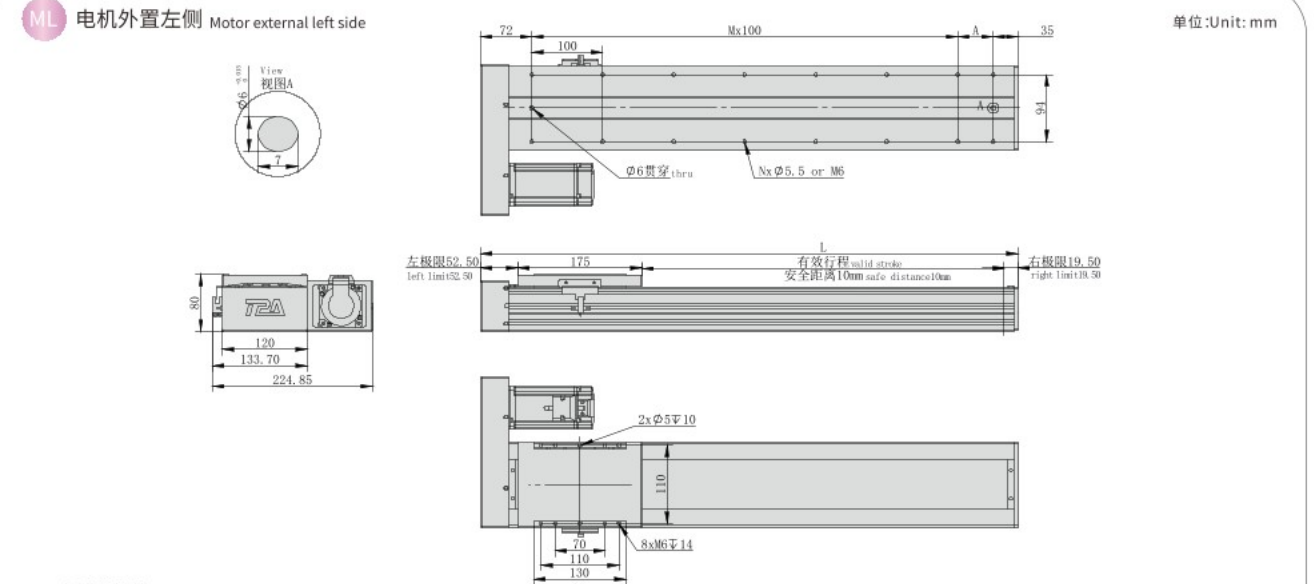

*不含电机重量。*Motor weight not included.

有效行程 Stroke	100	150	200	250	300	350	400	450	500	550	600	650	700	750	800	850	900	950	1000	1050	1100	1150	1200
L	357	407	457	507	557	607	657	707	757	807	857	907	957	1007	1057	1107	1157	1207	1257	1307	1357	1407	1457
A	50	100	50	100	50	100	50	100	50	100	50	100	50	100	50	100	50	100	50	100	50	100	50
N	8	8	10	10	12	12	14	14	16	16	18	18	20	20	22	22	24	24	26	26	28	28	30
M	2	2	3	3	4	4	5	5	6	6	7	7	8	8	9	9	10	10	11	11	12	12	13
KG	6.2	7.2	8.2	9.2	10.2	11.2	12.2	13.2	14.2	15.2	16.2	17.2	18.2	19.2	20.2	21.2	22.2	23.2	24.2	25.2	26.2	27.2	28.2

如有超长行程及定制需求, 请咨询我司业务。If you have extra long trip and custom requirements, please consult our business.

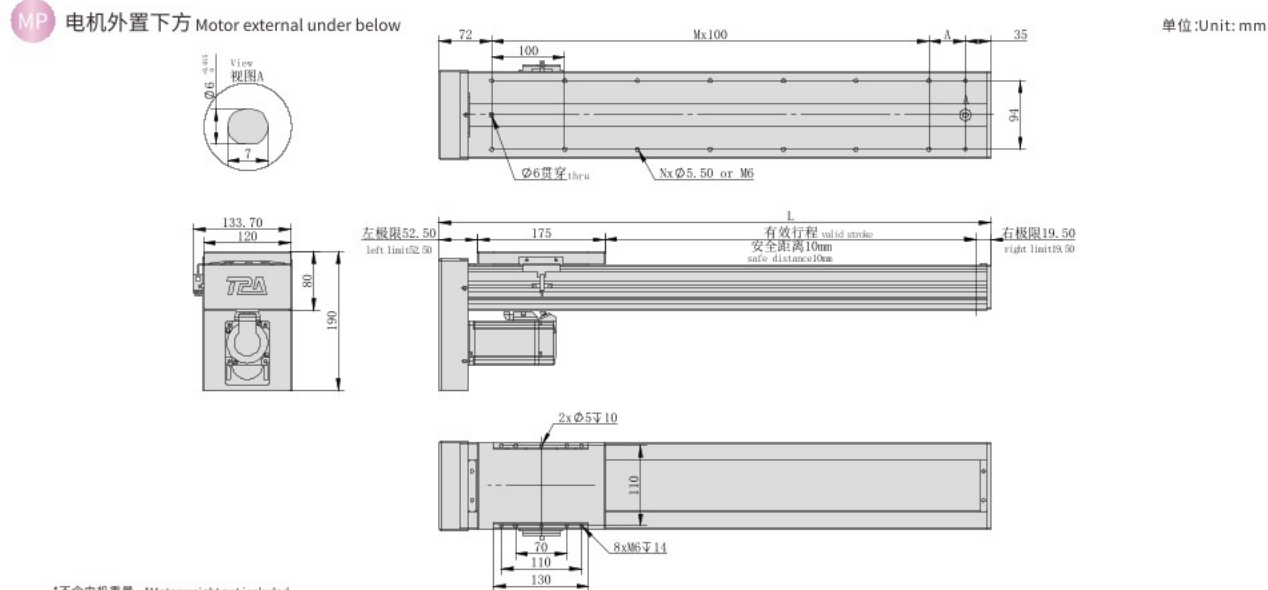

*不含电机重量。*Motor weight not included.

有效行程 Stroke	100	150	200	250	300	350	400	450	500	550	600	650	700	750	800	850	900	950	1000	1050	1100	1150	1200
L	357	407	457	507	557	607	657	707	757	807	857	907	957	1007	1057	1107	1157	1207	1257	1307	1357	1407	1457
A	50	100	50	100	50	100	50	100	50	100	50	100	50	100	50	100	50	100	50	100	50	100	50
N	8	8	10	10	12	12	14	14	16	16	18	18	20	20	22	22	24	24	26	26	28	28	30
M	2	2	3	3	4	4	5	5	6	6	7	7	8	8	9	9	10	10	11	11	12	12	13
KG	6.2	7.2	8.2	9.2	10.2	11.2	12.2	13.2	14.2	15.2	16.2	17.2	18.2	19.2	20.2	21.2	22.2	23.2	24.2	25.2	26.2	27.2	28.2

如有超长行程及定制需求, 请咨询我司业务。If you have extra long trip and custom requirements, please consult our business.

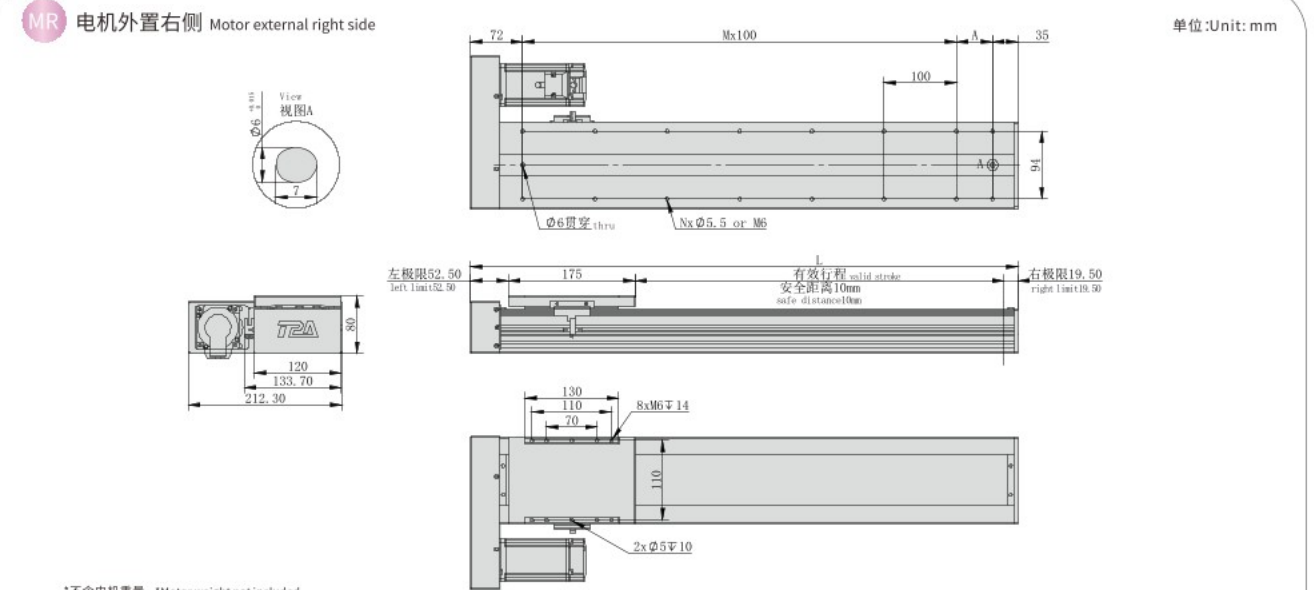

*不含电机重量。*Motor weight not included.

有效行程 Stroke	100	150	200	250	300	350	400	450	500	550	600	650	700	750	800	850	900	950	1000	1050	1100	1150	1200
L	357	407	457	507	557	607	657	707	757	807	857	907	957	1007	1057	1107	1157	1207	1257	1307	1357	1407	1457
A	50	100	50	100	50	100	50	100	50	100	50	100	50	100	50	100	50	100	50	100	50	100	50
N	8	8	10	10	12	12	14	14	16	16	18	18	20	20	22	22	24	24	26	26	28	28	30
M	2	2	3	3	4	4	5	5	6	6	7	7	8	8	9	9	10	10	11	11	12	12	13
KG	6.2	7.2	8.2	9.2	10.2	11.2	12.2	13.2	14.2	15.2	16.2	17.2	18.2	19.2	20.2	21.2	22.2	23.2	24.2	25.2	26.2	27.2	28.2

如有超长行程及定制需求, 请咨询我司业务。If you have extra long trip and custom requirements, please consult our business.

- HNR
- HCR
- HNB
- HCB
- HNT
- XYZ
- ONB
- OCB
- GCR
- GCB
- GCBS
- GCRS
- ESR
- EMR
- EHR
- KSR
- LNP
- DDR

参考资料
Reference data

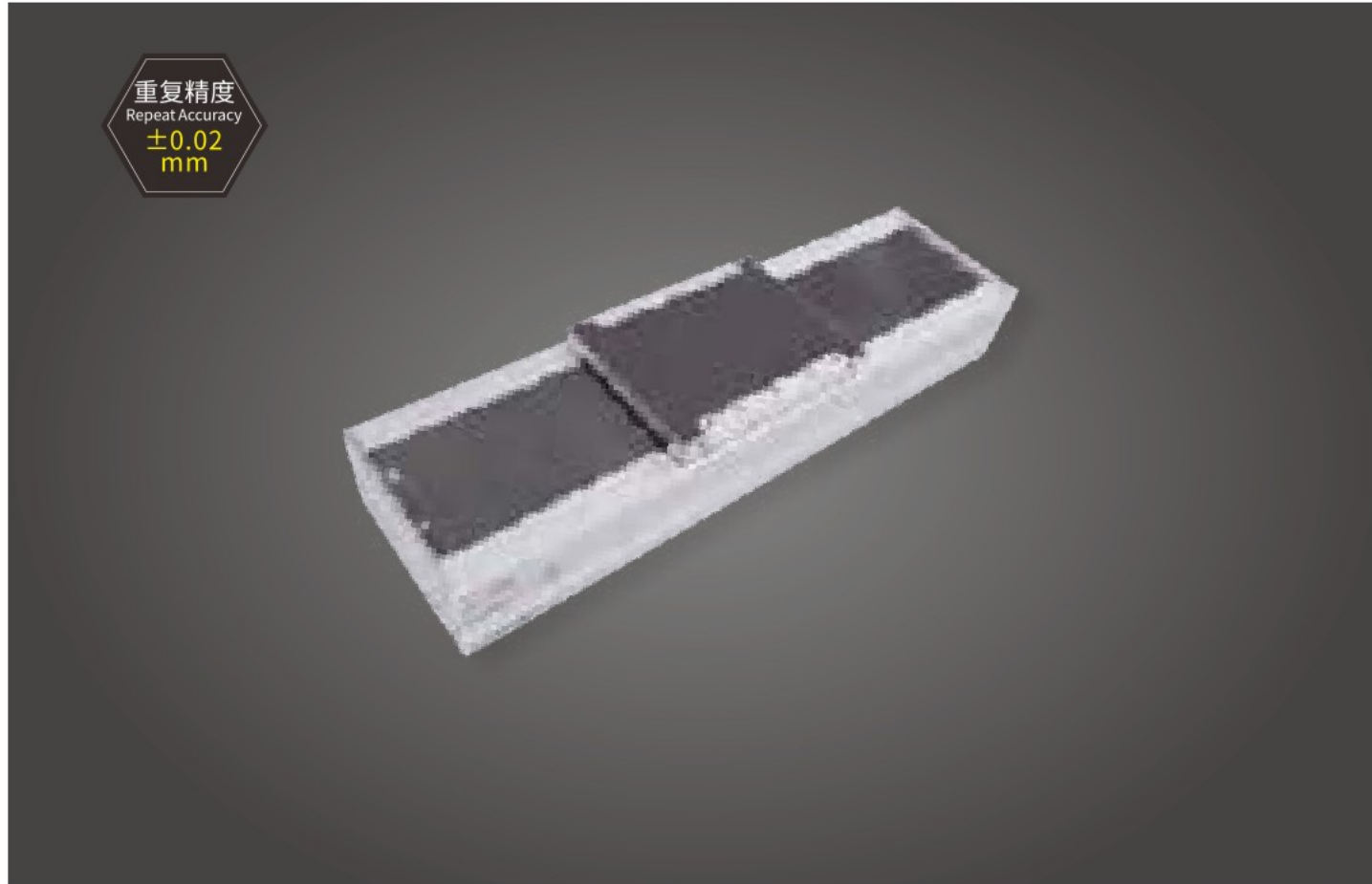

重复精度
Repeat Accuracy
±0.02
mm

此图仅供参考, 出货规格详见尺寸图面
This picture for reference only, specs details according with the drawing.

- 最大行程 Max stroke: 1400mm
- 最高速度 Max speed: 1000mm/s
- 马达容量 Motor output: 400W
- 滚珠螺杆 Ball screw: Ø20mm
- 直线滑轨 Linear guide: 15X12.5-2支

型号表达方式 Ordering method

TPA-HCR-140D-2010C-L1400-M-Y-P40-N3-F

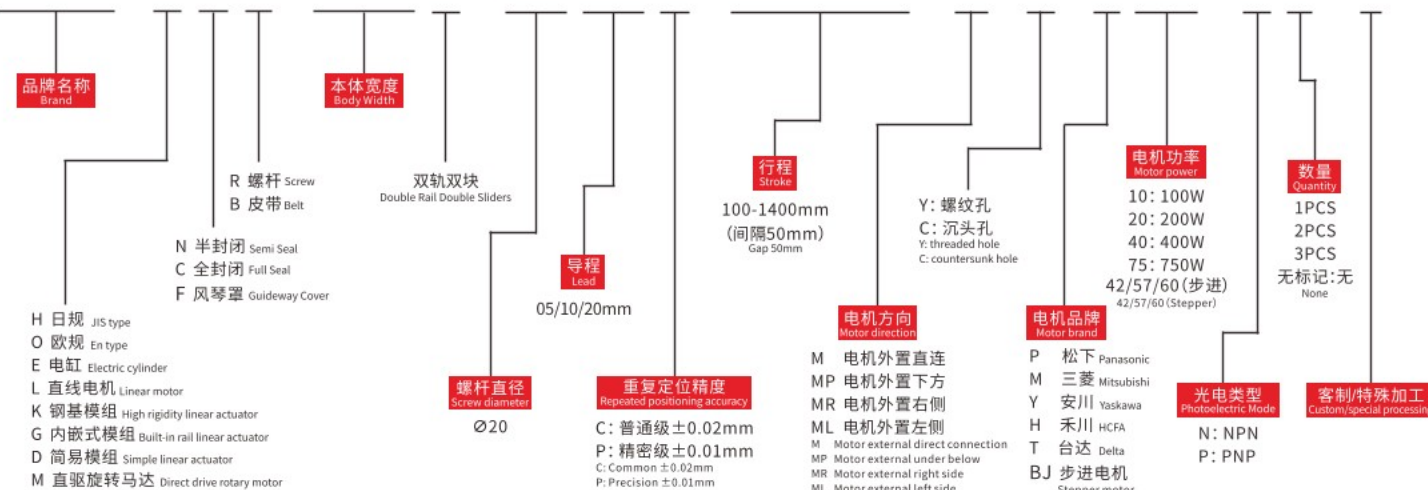

产品性能参数如下 Product performance parameters are as follows

规格 Spec	电机功率 (W) Motor power (W)	400			
	额定扭矩 (N.M) Rated torque (N.M)	1.3			
	重复定位精度 (mm) Repeated positioning accuracy (mm)	±0.02			
	导程 (mm) Lead (mm)	5	10	20	
	最高速度 (mm/s) Maximum speed (mm/s)	250	500	1000	
	电机额定转速 (RPM) Rated speed of motor (RPM)	3000			
	最大可搬重量 Maximum Payload	水平使用 (kg) Horizontal (kg)	70	35	18
		垂直使用 (kg) Vertical (kg)	31	16	8
	定规格推力 (N) Rated thrust (N)	1250	625	312	
	标准行程 (mm) Stroke pitch (mm)	100~1400mm/50 间隔 50 mm Pitch			
部品 Parts	滚珠螺杆外径 (mm) Ball screw Ø (mm)	Ø20			
	基座材质 Material of base	硬质挤压铝材A1 Hard extruded aluminum A1			
	安装面精度要求 (mm) Accuracy requirements of installation surface (mm)	C级<0.05; P级<0.02 C level<0.05 P level<0.02			
	使用环境 Operating environment	0~40°C, 85%RH (无凝结) No condensation			

注1: 使用非上述功率电机时请依据实际参数推算。
Note 1: When using a motor with a power other than the above, please calculate according to the actual parameters.
注2: 最高速度因行程和负载而异, 当螺杆细长比大于1:50时, 可能会因螺杆临界速度产生共振和抖动, 应适当下调运行速度, 一般螺杆每增长100mm, 速度应下调10~15%。
Note 2: The maximum speed varies with stroke and load. When the screw slenderness ratio is greater than 1:50, resonance and jitter may occur due to the critical speed of the screw, so the running speed should be reduced appropriately. Generally, the speed should be reduced by 10~15% for every 100mm increase of the screw.

容许负载力矩表 N.m Allowable overhang

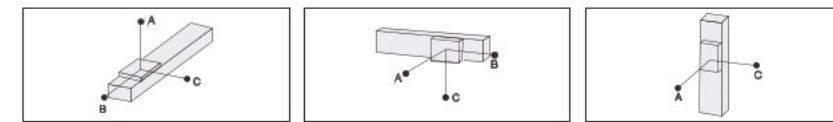

导程 Lead	水平安装 Horizontal installation				侧面安装 Side mounting				垂直安装 Vertical installation			
	A	B	C	重量	A	B	C	重量	A	B	C	重量
5	60kg	2515	242	232	55kg	257	269	2883	15kg	1118	1118	1118
10	80kg	1811	172	164	75kg	178	186	2000	22kg	770	770	770
20	95kg	1537	138	133	95kg	133	138	1537	27kg	626	626	626
5	30kg	2727	470	430	35kg	363	395	2368	10kg	1500	1500	1500
10	50kg	1577	266	242	55kg	218	238	1445	14kg	1072	1072	1072
20	75kg	1004	164	150	75kg	150	164	1004	18kg	833	833	833
5	10kg	2304	1222	1028	12kg	854	1019	2552	4kg	2980	2980	2980
10	22kg	1443	540	451	20kg	500	596	1588	7kg	1700	1700	1700
20	35kg	1005	324	271	35kg	271	324	1005	-	-	-	-

传感器连接图<原点及端点> Sensor layout

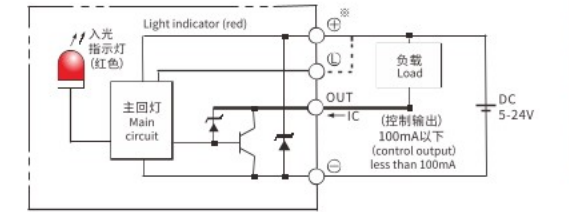

静态容许负载惯量 Static loading moment

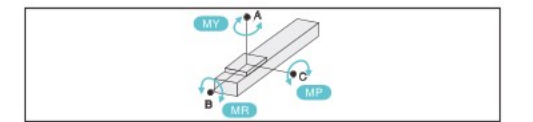

位置	惯量 (N.m)
MY	551
MP	552
MR	485

*力矩表所表示的数据, 代表重心。
The torque value in the chart indicate the center of gravity.
*符合型录规范的正常试用下, 保证寿命为10000公里。
Operation life is 10,000km when the product is using under the specified conditions.
*倒吊使用无法套用标准规范, 如有需求请咨询我司业务。
The standard specification cannot be applied to the use of inverted crane. Please consult our business if necessary.

搭配伺服马达一览表 Suitable motor brand

品牌 Brand	马达记号 Mark	刹车有无 Brake	马达容量 Motor capacity	电源电压 AC-Voltage	伺服马达型号 Servo motor model	驱动器型号 Driver Model
三菱 Mitsubishi	M	无刹车(水平式样) No brake (horizontal type)	200	220	HG-KR73	MR-J4-70A
松下 Panasonic	P	无刹车(水平式样) No brake (horizontal type)	200	220	MHMD082G1U	MBDHT3520
台达 Delta	T	无刹车(水平式样) No brake (horizontal type)	200	220	ECMA-C20807ES	ASD-B20721-B



电机外置直连/电机外置下方
Motor external direct connection/Motor external under below

M 电机外置直连 Motor external direct connection

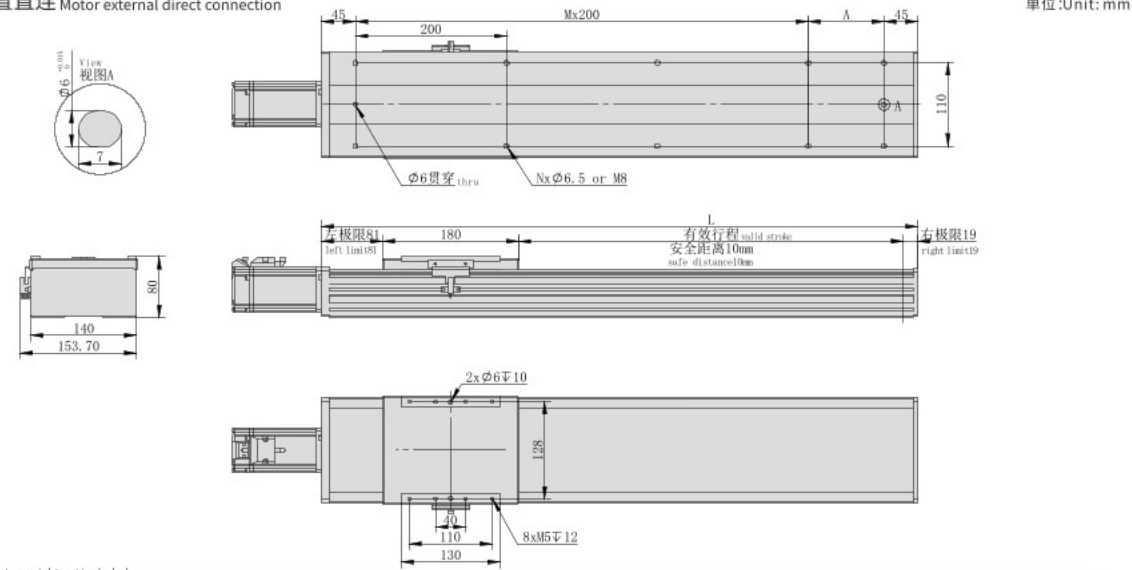

*不含电机重量。*Motor weight not included.

有效行程 Stroke	100	150	200	250	300	350	400	450	500	550	600	650	700	750	800	850	900	950	1000	1050	1100	1150	1200	1250	1300	1350	1400
L	390	440	490	540	590	640	690	740	790	840	890	940	990	1040	1090	1140	1190	1240	1290	1340	1390	1440	1490	1540	1590	1640	1690
A	100	150	200	50	100	150	200	50	100	150	200	50	100	150	200	50	100	150	200	50	100	150	200	50	100	150	200
N	6	6	6	8	8	8	8	10	10	10	10	12	12	12	12	14	14	14	14	16	16	16	16	18	18	18	18
M	1	1	1	2	2	2	2	3	3	3	3	4	4	4	4	5	5	5	5	6	6	6	6	7	7	7	7
KG	7.8	8.3	8.8	9.3	9.8	10.3	10.8	11.3	11.8	12.3	12.8	13.3	13.8	14.3	14.8	15.3	15.8	16.3	16.8	17.3	17.8	18.3	18.8	19.3	19.8	20.3	20.8

如有超长行程及定制需求, 请咨询我司业务。If you have extra long trip and custom requirements, please consult our business.

电机外置左侧/电机外置右侧
Motor external left side / Motor external right side

ML 电机外置左侧 Motor external left side

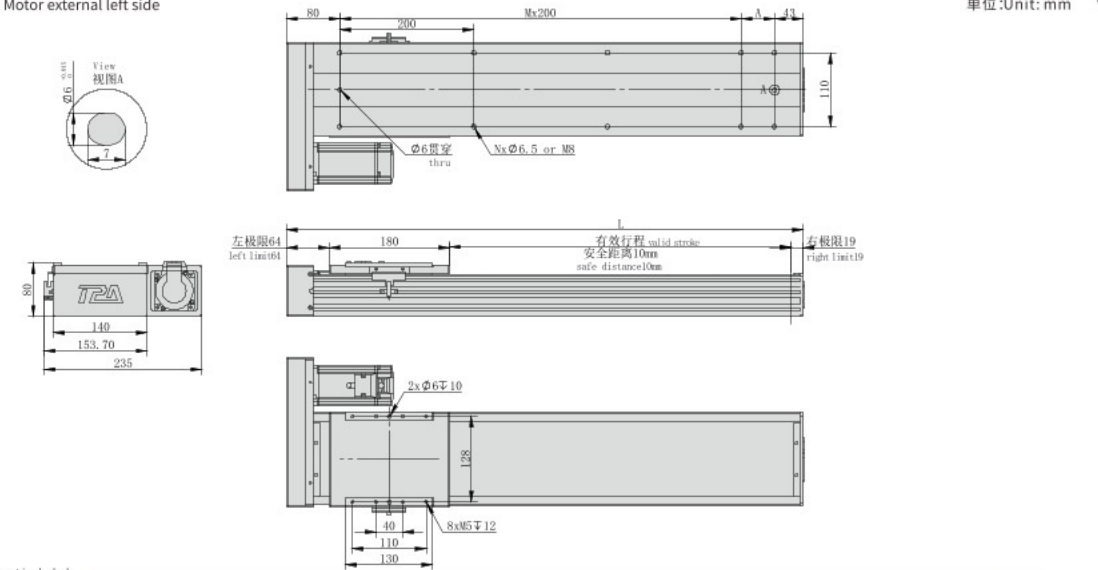

*不含电机重量。*Motor weight not included.

有效行程 Stroke	100	150	200	250	300	350	400	450	500	550	600	650	700	750	800	850	900	950	1000	1050	1100	1150	1200	1250	1300	1350	1400
L	373	423	473	523	573	623	673	723	773	823	873	923	973	1023	1073	1123	1173	1223	1273	1323	1373	1423	1473	1523	1573	1623	1673
A	100	150	200	50	100	150	200	50	100	150	200	50	100	150	200	50	100	150	200	50	100	150	200	50	100	150	200
N	6	6	6	6	8	8	8	8	10	10	10	10	12	12	12	12	14	14	14	14	16	16	16	16	18	18	18
M	1	1	1	1	2	2	2	2	3	3	3	3	4	4	4	4	5	5	5	5	6	6	6	6	7	7	7
KG	8.2	8.7	9.2	9.7	10.2	10.7	11.2	11.7	12.2	12.7	13.2	13.7	14.2	14.7	15.2	15.7	16.2	16.7	17.2	17.7	18.2	18.7	19.2	19.7	20.2	20.7	21.2

如有超长行程及定制需求, 请咨询我司业务。If you have extra long trip and custom requirements, please consult our business.

MP 电机外置下方 Motor external under below

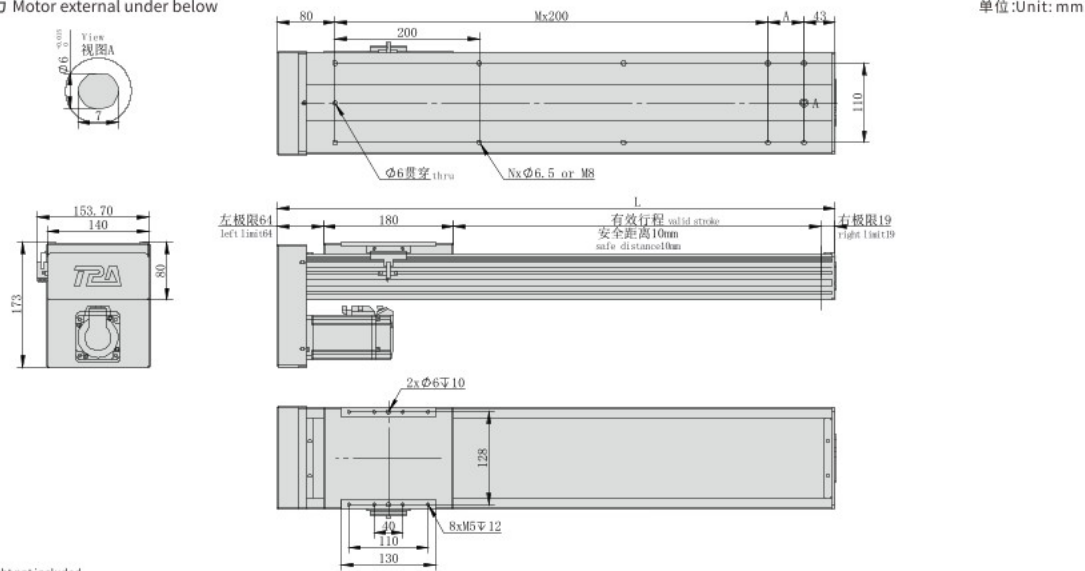

*不含电机重量。*Motor weight not included.

有效行程 Stroke	100	150	200	250	300	350	400	450	500	550	600	650	700	750	800	850	900	950	1000	1050	1100	1150	1200	1250	1300	1350	1400
L	373	423	473	523	573	623	673	723	773	823	873	923	973	1023	1073	1123	1173	1223	1273	1323	1373	1423	1473	1523	1573	1623	1673
A	100	150	200	50	100	150	200	50	100	150	200	50	100	150	200	50	100	150	200	50	100	150	200	50	100	150	200
N	6	6	6	6	8	8	8	8	10	10	10	10	12	12	12	12	14	14	14	14	16	16	16	16	18	18	18
M	1	1	1	1	2	2	2	2	3	3	3	3	4	4	4	4	5	5	5	5	6	6	6	6	7	7	7
KG	8.2	8.7	9.2	9.7	10.2	10.7	11.2	11.7	12.2	12.7	13.2	13.7	14.2	14.7	15.2	15.7	16.2	16.7	17.2	17.7	18.2	18.7	19.2	19.7	20.2	20.7	21.2

如有超长行程及定制需求, 请咨询我司业务。If you have extra long trip and custom requirements, please consult our business.

MR 电机外置右侧 Motor external right side

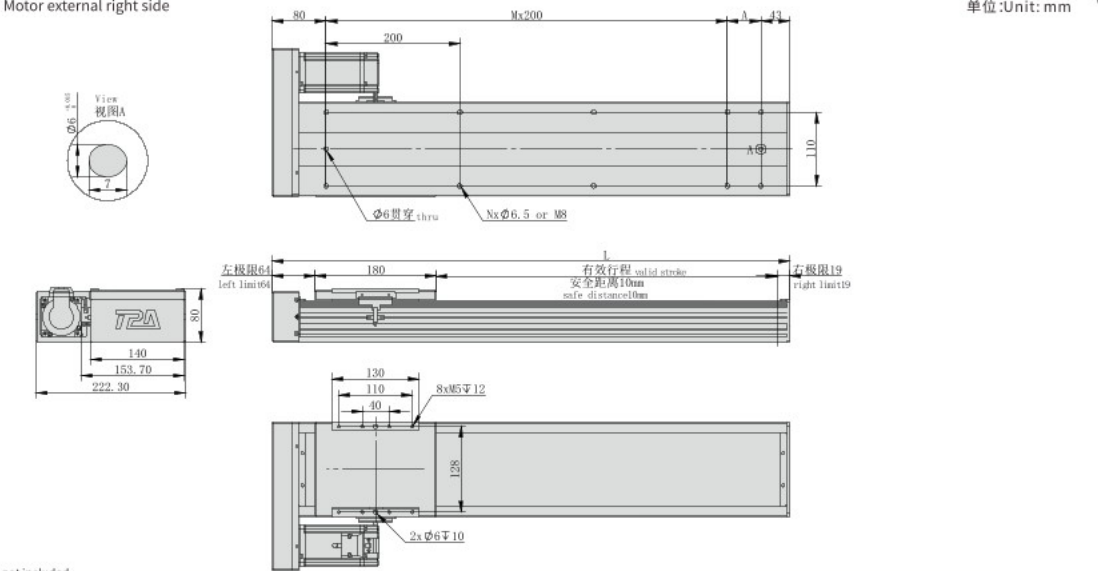

*不含电机重量。*Motor weight not included.

有效行程 Stroke	100	150	200	250	300	350	400	450	500	550	600	650	700	750	800	850	900	950	1000	1050	1100	1150	1200	1250	1300	1350	1400
L	373	423	473	523	573	623	673	723	773	823	873	923	973	1023	1073	1123	1173	1223	1273	1323	1373	1423	1473	1523	1573	1623	1673
A	100	150	200	50	100	150	200	50	100	150	200	50	100	150	200	50	100	150	200	50	100	150	200	50	100	150	200
N	6	6	6	6	8	8	8	8	10	10	10	10	12	12	12	12	14	14	14	14	16	16	16	16	18	18	18
M	1	1	1	1	2	2	2	2	3	3	3	3	4	4	4	4	5	5	5	5	6	6	6	6	7	7	7
KG	8.2	8.7	9.2	9.7	10.2	10.7	11.2	11.7	12.2	12.7	13.2	13.7	14.2	14.7	15.2	15.7	16.2	16.7	17.2	17.7	18.2	18.7	19.2	19.7	20.2	20.7	21.2

如有超长行程及定制需求, 请咨询我司业务。If you have extra long trip and custom requirements, please consult our business.

- HNR
- HCR
- HNB
- HCB
- HNT
- XYZ
- ONB
- OCB
- GCR
- GCB
- GCBS
- GCRS
- ESR
- EMR
- EHR
- KSR
- LNP
- DDR

参考资料
Reference data



电机外置直连/电机外置下方
Motor external direct connection/Motor external under below

M 电机外置直连 Motor external direct connection

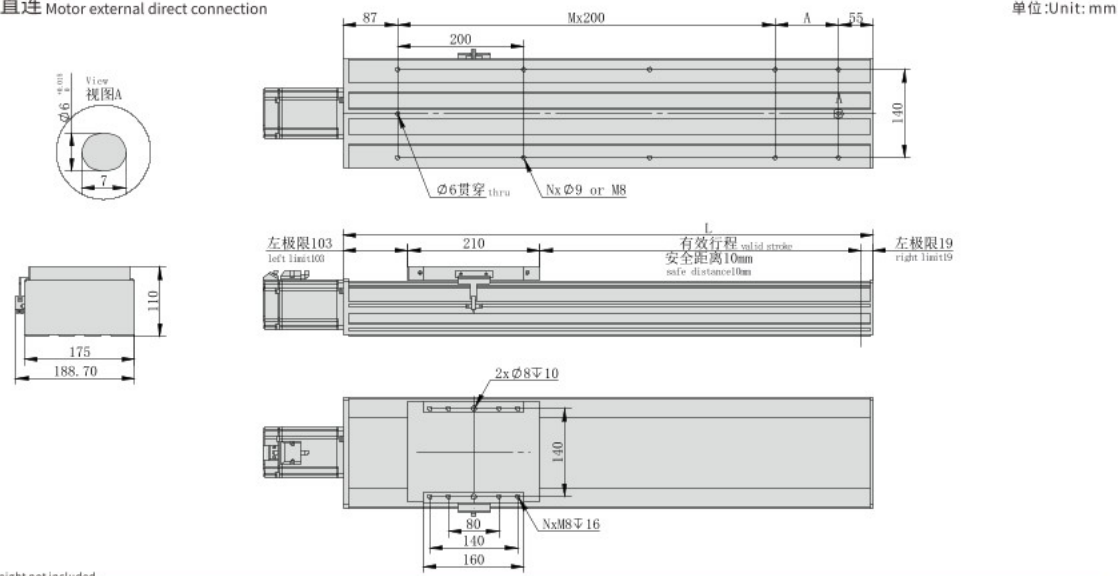

*不含电机重量。*Motor weight not included.

有效行程 Stroke	100	150	200	250	300	350	400	450	500	550	600	650	700	750	800	850	900	950	1000	1050	1100	1150	1200	1250	1300	1350	1400	1450	1500	1550	1600	1650	1700	1750	1800
L	442	492	542	592	642	692	742	792	842	892	942	992	1042	1092	1142	1192	1242	1292	1342	1392	1442	1492	1542	1592	1642	1692	1742	1792	1842	1892	1942	1992	2042	2092	2142
A	100	150	200	50	100	150	200	50	100	150	200	50	100	150	200	50	100	150	200	50	100	150	200	50	100	150	200	50	100	150	200	50	100	150	200
N	6	6	6	8	8	8	8	10	10	10	10	12	12	12	12	14	14	14	14	16	16	16	16	18	18	18	18	20	20	20	20	22	22	22	22
M	2	2	2	3	3	3	3	4	4	4	4	5	5	5	5	6	6	6	6	7	7	7	7	8	8	8	8	9	9	9	9	10	10	10	10
KG	12.5	13.5	14.5	15.5	16.5	17.5	18.5	19.5	20.5	21.5	22.5	23.5	24.5	25.5	26.5	27.5	28.5	29.5	30.5	31.5	32.5	33.5	34.5	35.5	36.5	37.5	38.5	39.5	40.5	41.5	42.5	43.5	44.5	45.5	46.5

如有超长行程及定制需求, 请咨询我司业务。If you have extra long trip and custom requirements, please consult our business.

电机外置左侧/电机外置右侧
Motor external left side / Motor external right side

ML 电机外置左侧 Motor external left side

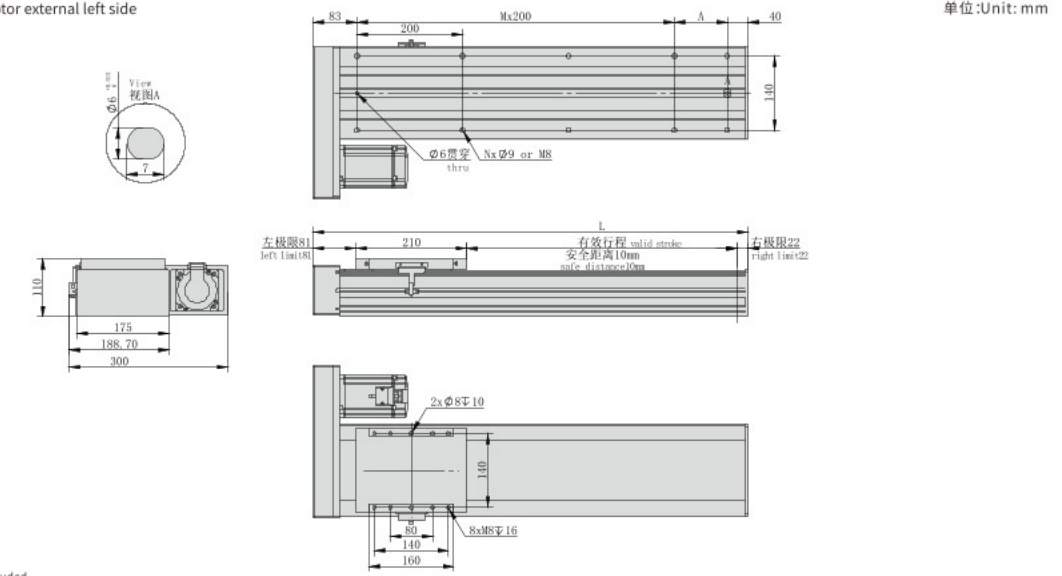

*不含电机重量。*Motor weight not included.

有效行程 Stroke	100	150	200	250	300	350	400	450	500	550	600	650	700	750	800	850	900	950	1000	1050	1100	1150	1200	1250	1300	1350	1400	1450	1500	1550	1600	1650	1700	1750	1800
L	423	473	523	573	623	673	723	773	823	873	923	973	1023	1073	1123	1173	1223	1273	1323	1373	1423	1473	1523	1573	1623	1673	1723	1773	1823	1873	1923	1973	2023	2073	2123
A	100	150	200	50	100	150	200	50	100	150	200	50	100	150	200	50	100	150	200	50	100	150	200	50	100	150	200	50	100	150	200	50	100	150	200
N	6	6	6	8	8	8	8	10	10	10	10	12	12	12	12	14	14	14	14	16	16	16	16	18	18	18	18	20	20	20	20	22	22	22	22
M	2	2	2	3	3	3	3	4	4	4	4	5	5	5	5	6	6	6	6	7	7	7	7	8	8	8	8	9	9	9	9	10	10	10	10
KG	12	13	14	15	16	17	18	19	20	21	22	23	24	25	26	27	28	29	30	31	32	33	34	35	36	37	38	39	40	41	42	43	44	45	46

如有超长行程及定制需求, 请咨询我司业务。If you have extra long trip and custom requirements, please consult our business.

MP 电机外置下方 Motor external under below

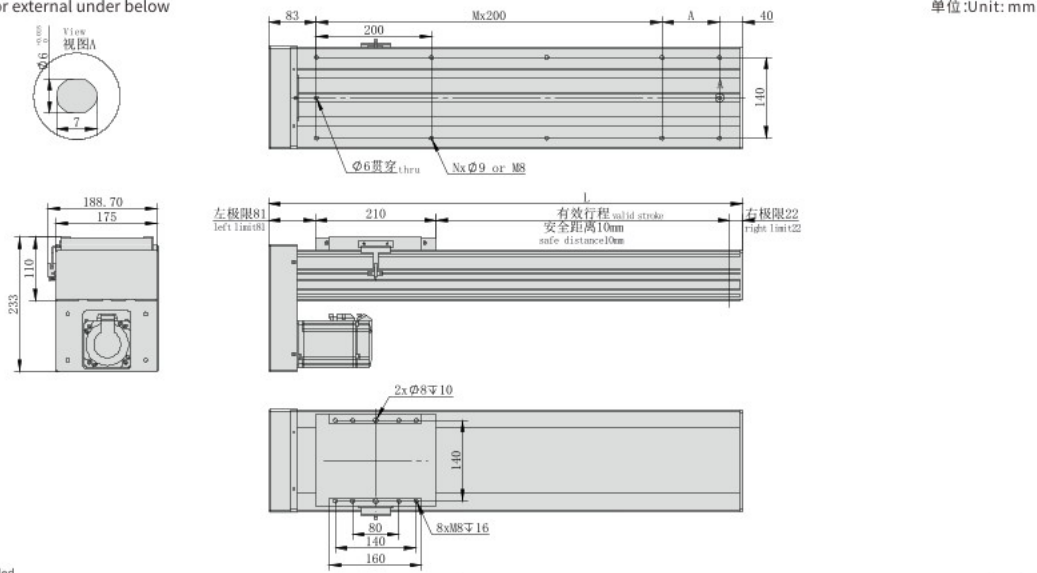

*不含电机重量。*Motor weight not included.

有效行程 Stroke	100	150	200	250	300	350	400	450	500	550	600	650	700	750	800	850	900	950	1000	1050	1100	1150	1200	1250	1300	1350	1400	1450	1500	1550	1600	1650	1700	1750	1800
L	423	473	523	573	623	673	723	773	823	873	923	973	1023	1073	1123	1173	1223	1273	1323	1373	1423	1473	1523	1573	1623	1673	1723	1773	1823	1873	1923	1973	2023	2073	2123
A	100	150	200	50	100	150	200	50	100	150	200	50	100	150	200	50	100	150	200	50	100	150	200	50	100	150	200	50	100	150	200	50	100	150	200
N	6	6	6	8	8	8	8	10	10	10	10	12	12	12	12	14	14	14	14	16	16	16	16	18	18	18	18	20	20	20	20	22	22	22	22
M	2	2	2	3	3	3	3	4	4	4	4	5	5	5	5	6	6	6	6	7	7	7	7	8	8	8	8	9	9	9	9	10	10	10	10
KG	12	13	14	15	16	17	18	19	20	21	22	23	24	25	26	27	28	29	30	31	32	33	34	35	36	37	38	39	40	41	42	43	44	45	46

如有超长行程及定制需求, 请咨询我司业务。If you have extra long trip and custom requirements, please consult our business.

MR 电机外置右侧 Motor external right side

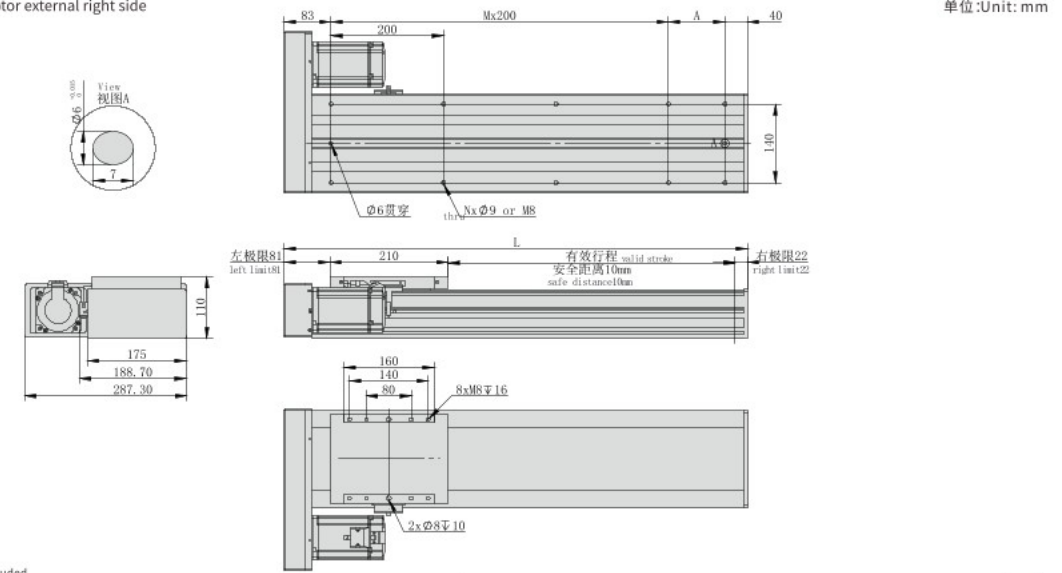

*不含电机重量。*Motor weight not included.

有效行程 Stroke	100	150	200	250	300	350	400	450	500	550	600	650	700	750	800	850	900	950	1000	1050	1100	1150	1200	1250	1300	1350	1400	1450	1500	1550	1600	1650	1700	1750	1800
L	423	473	523	573	623	673	723	773	823	873	923	973	1023	1073	1123	1173	1223	1273	1323	1373	1423	1473	1523	1573	1623	1673	1723	1773	1823	1873	1923	1973	2023	2073	2123
A	100	150	200	50	100	150	200	50	100	150	200	50	100	150	200	50	100	150	200	50	100	150	200	50	100	150	200	50	100	150	200	50	100	150	200
N	6	6	6	8	8	8	8	10	10	10	10	12	12	12	12	14	14	14	14	16	16	16	16	18	18	18	18	20	20	20	20	22	22	22	22
M	2	2	2	3	3	3	3	4	4	4	4	5	5	5	5	6	6	6	6	7	7	7	7	8	8	8	8	9	9	9	9	10	10	10	10
KG	12	13	14	15	16	17	18	19	20	21	22	23	24	25	26	27	28	29	30	31	32	33	34	35	36	37	38	39	40	41	42	43	44	45	46

如有超长行程及定制需求, 请咨询我司业务。If you have extra long trip and custom requirements, please consult our business.

- HNR
- HCR
- HNB
- HCB
- HNT
- XYZ
- ONB
- OCB
- GCR
- GCB
- GCBS
- GCRS
- ESR
- EMR
- EHR
- KSR
- LNP
- DDR

参考资料
Reference data



重复精度
Repeat Accuracy
±0.02
mm

此图仅供参考, 出货规格详见尺寸图面
This picture for reference only, specs details according with the drawing.

- 最大行程 Max stroke: 1800mm
- 最高速度 Max speed: 1250mm/s
- 马达容量 Motor output: 750W
- 滚珠螺杆 Ball screw: Ø25mm
- 直线滑轨 Linear guide: 23X18-2支

型号表达方式 Ordering method

TPA-HCR-202D-2510C-L1800-M-Y-P75-N3-F

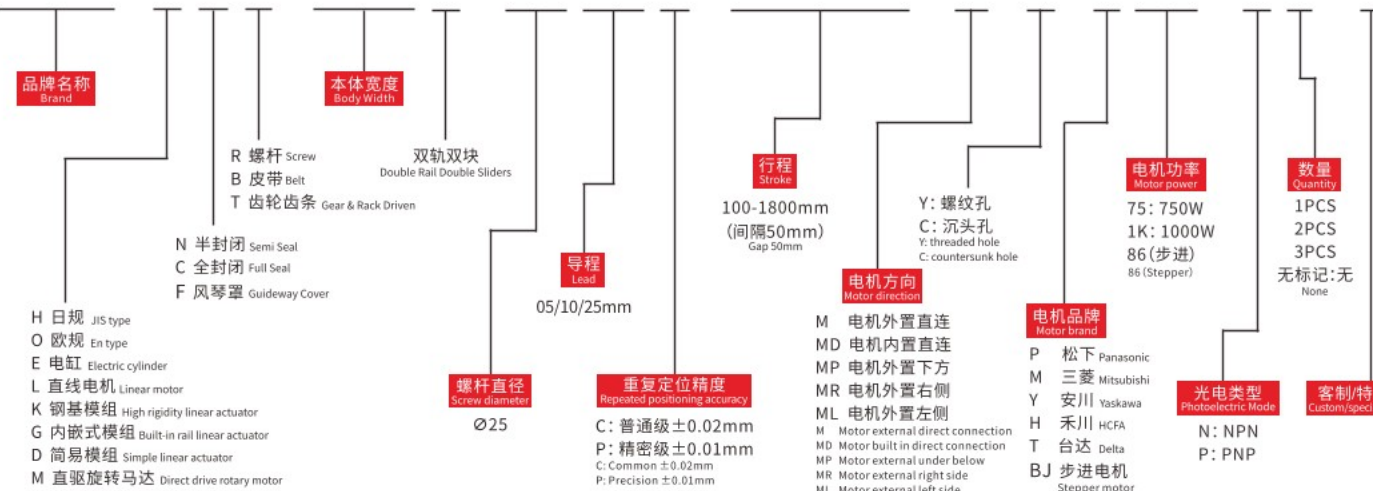

产品性能参数如下 Product performance parameters are as follows

电机功率 (W) Motor power (W)	750		
额定扭矩 (N.M) Rated torque (N.M)	2.4		
重复定位精度 (mm) Repeated positioning accuracy (mm)	±0.02		
导程 (mm) Lead (mm)	5	10	25
最高速度 (mm/s) Maximum speed (mm/s)	250	500	1250
电机额定转速 (RPM) Rated speed of motor (RPM)	3000		
最大可搬重量 Maximum Payload	水平使用 (kg) Horizontal (kg)	160	64
	垂直使用 (kg) Vertical (kg)	58	19
定格推力 (N) Rated thrust (N)	2306	1153	577
标准行程 (mm) Stroke pitch (mm)	100~1800mm/50 间隔 50 mm Pitch		
滚珠螺杆外径 (mm) Ball screw Ø (mm)	Ø25		
基座材质 Material of base	硬质挤压铝材A1 Hard extruded aluminum A1		
安装面精度要求 (mm) Accuracy requirements of installation surface (mm)	C级<0.05; P级<0.02 C level<0.05 P level<0.02		
使用环境 Operating environment	0~40°C, 85%RH (无凝结) No condensation		

注1: 使用非上述功率电机时请依据实际参数推算。
Note 1: When using a motor with a power other than the above, please calculate according to the actual parameters.

注2: 最高速度因行程和负载而异, 当螺杆细长比大于1:50时, 可能会因螺杆临界速度产生共振和抖动, 应适当下调运行速度, 一般螺杆每增长100mm, 速度应下调10~15%。
Note 2: The maximum speed varies with stroke and load. When the screw slenderness ratio is greater than 1:50, resonance and jitter may occur due to the critical speed of the screw, so the running speed should be reduced appropriately. Generally, the speed should be reduced by 10~15% for every 100mm increase of the screw.

容许负载力矩表 N.m Allowable overhang

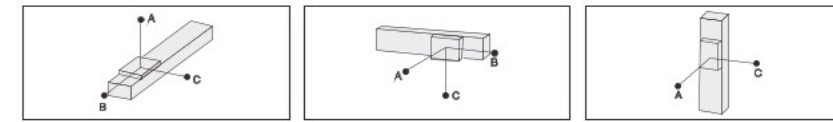

(单位Unit:mm)				(单位Unit:mm)				(单位Unit:mm)			
水平安装 Horizontal installation				侧面安装 Side mounting				垂直安装 Vertical installation			
导程 Lead	A	B	C	导程 Lead	A	B	C	导程 Lead	A	B	C
5	40kg	1000	400	580	40kg	380	380	1000	10kg	1200	1200
	80kg	780	230	350	80kg	190	250	740	20kg	710	710
	100kg	680	185	230	100kg	140	190	620	30kg	560	560
10	40kg	900	350	505	40kg	250	310	860	8kg	1000	1000
	80kg	710	200	300	80kg	130	170	620	18kg	600	600
	100kg	610	160	200	100kg	90	130	500	27kg	400	400
25	20kg	1100	600	500	20kg	350	350	700	5kg	1100	1100
	40kg	790	370	300	40kg	200	205	470	10kg	800	800
	60kg	670	250	190	60kg	120	130	370	-	-	-

传感器连接图<原点及端点> Sensor layout

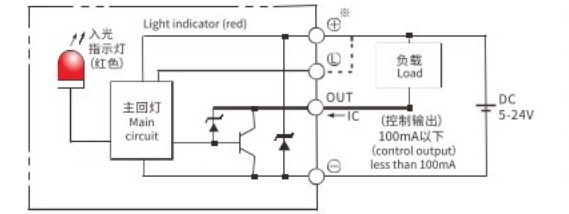

- HNR
- HCR
- HNB
- HCB
- HNT
- XYZ
- ONB
- OCB
- GCR
- GCB
- GCBS
- GCRS
- ESR
- EMR
- EHR
- KSR
- LNP
- DDR
- 参考资料 Reference data

静态容许负载惯量 Static loading moment

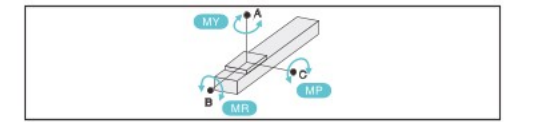

(单位Unit:N.m)	
MY	2052
MP	2052
MR	1810

*力矩表所表示的数据, 代表重心。
The torque value in the chart indicate the center of gravity.
*符合型录规范的正常试用下, 保证寿命为10000公里。
Operation life is 10,000km when the product is using under the specified conditions.
*倒吊使用无法套用标准规范, 如有需求请咨询我司业务。
The standard specification cannot be applied to the use of inverted crane. Please consult our business if necessary.

搭配伺服马达一览表 Suitable motor brand

品牌 Brand	马达记号 Mark	刹车有无 Brake	马达容量 Motor capacity	电源电压 AC-Voltage	伺服马达型号 Servo motor model	驱动器型号 Driver Model
三菱 Mitsubishi	M	无刹车(水平式样) No brake (horizontal type)	200	220	HG-KR73	MR-J4-70A
松下 Panasonic	P	无刹车(水平式样) No brake (horizontal type)	200	220	MHMD082G1U	MBDHT3520
台达 Delta	T	无刹车(水平式样) No brake (horizontal type)	200	220	ECMA-C20807ES	ASD-B20721-B



电机外置直连/电机外置下方
Motor external direct connection/Motor external under below

M 电机外置直连 Motor external direct connection

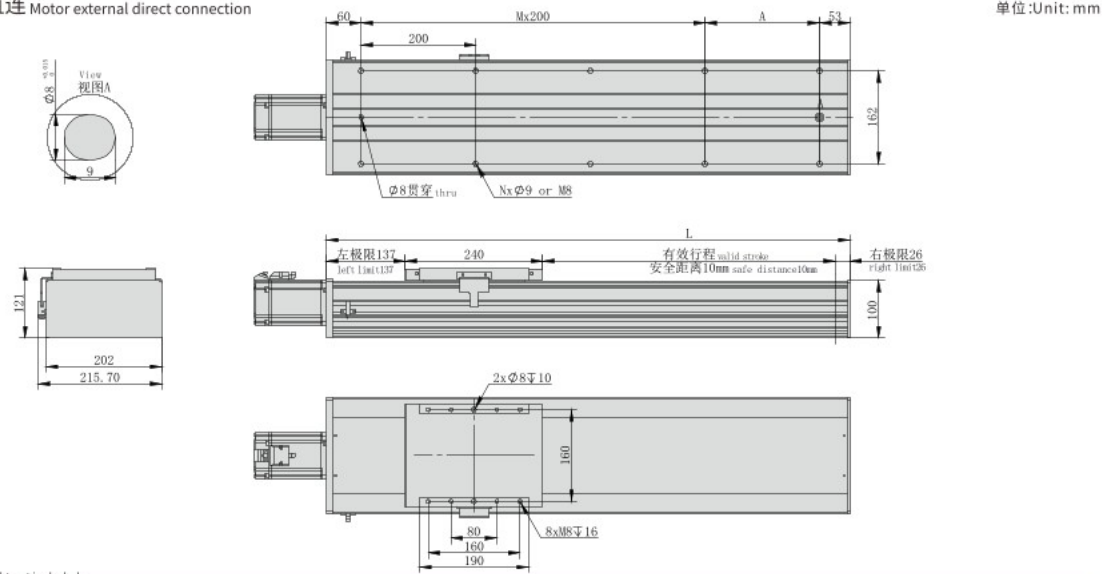

*不含电机重量。*Motor weight not included.

有效行程 Stroke	100	150	200	250	300	350	400	450	500	550	600	650	700	750	800	850	900	950	1000	1050	1100	1150	1200	1250	1300	1350	1400	1450	1500	1550	1600	1650	1700	1750	1800
L	513	563	613	663	713	763	813	863	913	963	1013	1063	1113	1163	1213	1263	1313	1363	1413	1463	1513	1563	1613	1663	1713	1763	1813	1863	1913	1963	2013	2063	2113	2163	2213
A	200	50	100	150	200	50	100	150	200	50	100	150	200	50	100	150	200	50	100	150	200	50	100	150	200	50	100	150	200	50	100	150	200	50	100
N	6	8	8	8	8	10	10	10	10	12	12	12	12	14	14	14	14	16	16	16	16	18	18	18	18	20	20	20	22	22	22	22	24	24	24
M	1	2	2	2	2	3	3	3	3	4	4	4	4	5	5	5	5	6	6	6	6	7	7	7	7	8	8	8	8	9	9	9	9	10	10
KG	23.7	24.9	26.1	27.3	28.5	29.7	30.9	32.1	33.3	34.5	35.7	36.9	38.1	39.3	40.5	41.7	42.9	44.1	45.3	46.5	47.7	48.9	50.1	51.3	52.5	53.7	54.9	56.1	57.3	58.5	59.7	60.9	62.1	63.3	64.5

如有超长行程及定制需求, 请咨询我司业务。If you have extra long trip and custom requirements, please consult our business.

电机外置左侧/电机外置右侧
Motor external left side / Motor external right side

ML 电机外置左侧 Motor external left side

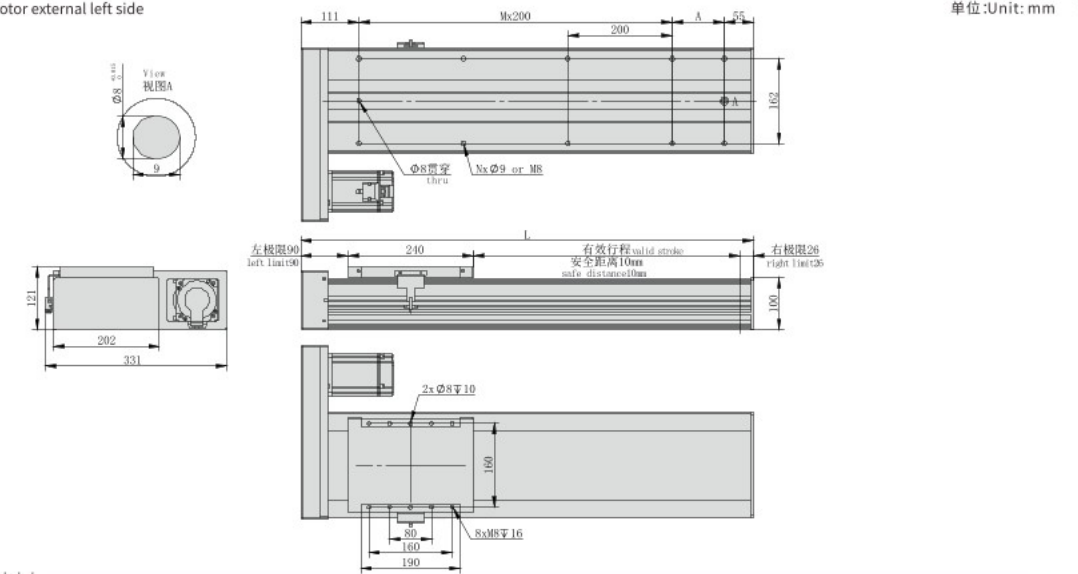

*不含电机重量。*Motor weight not included.

有效行程 Stroke	100	150	200	250	300	350	400	450	500	550	600	650	700	750	800	850	900	950	1000	1050	1100	1150	1200	1250	1300	1350	1400	1450	1500	1550	1600	1650	1700	1750	1800
L	466	516	566	616	666	716	766	816	866	916	966	1016	1066	1116	1166	1216	1266	1316	1366	1416	1466	1516	1566	1616	1666	1716	1766	1816	1866	1916	1966	2016	2066	2116	2166
A	100	150	200	50	100	150	200	50	100	150	200	50	100	150	200	50	100	150	200	50	100	150	200	50	100	150	200	50	100	150	200	50	100	150	200
N	6	6	6	8	8	8	8	10	10	10	10	12	12	12	12	14	14	14	14	16	16	16	16	18	18	18	18	20	20	20	20	22	22	22	22
M	1	1	1	1	2	2	2	3	3	3	3	4	4	4	4	5	5	5	5	6	6	6	6	7	7	7	7	8	8	8	8	9	9	9	9
KG	24.1	25.3	26.5	27.7	28.9	30.1	31.3	32.5	33.7	34.9	36.1	37.3	38.5	39.7	40.9	42.1	43.3	44.5	45.7	46.9	48.1	49.3	50.5	51.7	52.9	54.1	55.3	56.5	57.7	58.9	60.1	61.3	62.5	63.7	64.9

如有超长行程及定制需求, 请咨询我司业务。If you have extra long trip and custom requirements, please consult our business.

MP 电机外置下方 Motor external under below

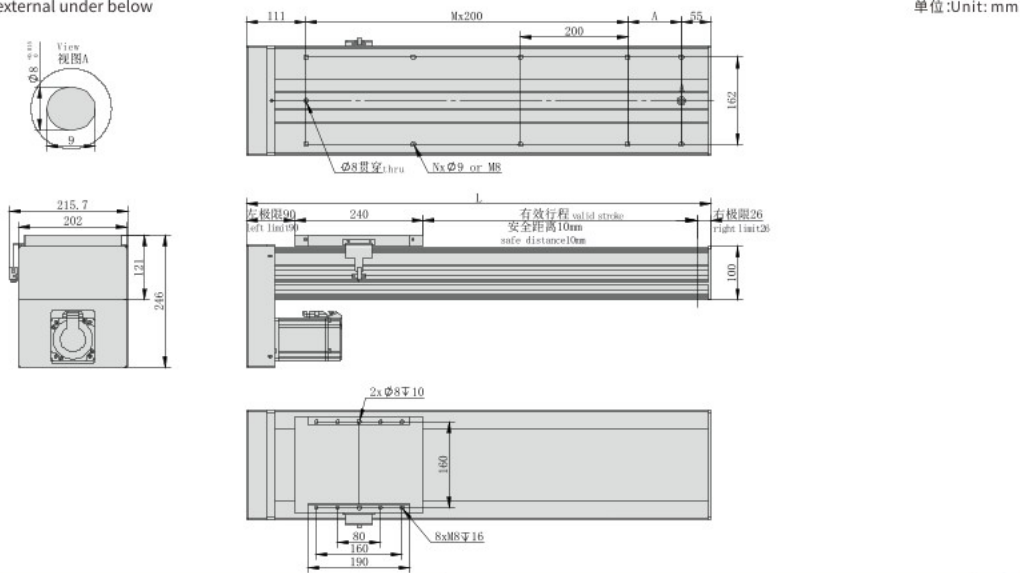

*不含电机重量。*Motor weight not included.

有效行程 Stroke	100	150	200	250	300	350	400	450	500	550	600	650	700	750	800	850	900	950	1000	1050	1100	1150	1200	1250	1300	1350	1400	1450	1500	1550	1600	1650	1700	1750	1800
L	466	516	566	616	666	716	766	816	866	916	966	1016	1066	1116	1166	1216	1266	1316	1366	1416	1466	1516	1566	1616	1666	1716	1766	1816	1866	1916	1966	2016	2066	2116	2166
A	100	150	200	50	100	150	200	50	100	150	200	50	100	150	200	50	100	150	200	50	100	150	200	50	100	150	200	50	100	150	200	50	100	150	200
N	6	6	6	8	8	8	8	10	10	10	10	12	12	12	12	14	14	14	14	16	16	16	16	18	18	18	18	20	20	20	20	22	22	22	22
M	1	1	1	1	2	2	2	3	3	3	3	4	4	4	4	5	5	5	5	6	6	6	6	7	7	7	7	8	8	8	8	9	9	9	9
KG	24.1	25.3	26.5	27.7	28.9	30.1	31.3	32.5	33.7	34.9	36.1	37.3	38.5	39.7	40.9	42.1	43.3	44.5	45.7	46.9	48.1	49.3	50.5	51.7	52.9	54.1	55.3	56.5	57.7	58.9	60.1	61.3	62.5	63.7	64.9

如有超长行程及定制需求, 请咨询我司业务。If you have extra long trip and custom requirements, please consult our business.

MR 电机外置右侧 Motor external right side

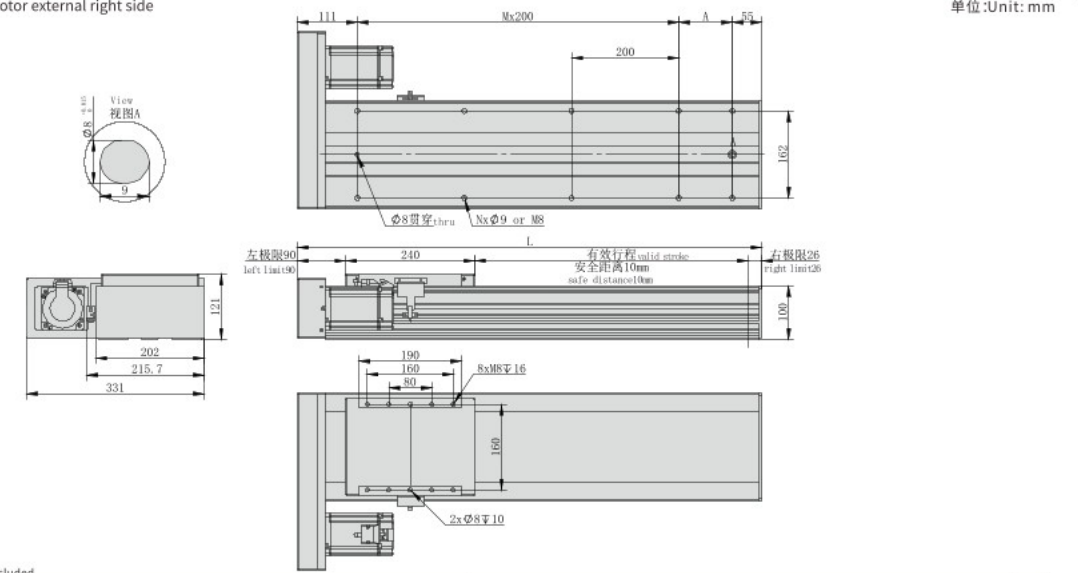

*不含电机重量。*Motor weight not included.

有效行程 Stroke	100	150	200	250	300	350	400	450	500	550	600	650	700	750	800	850	900	950	1000	1050	1100	1150	1200	1250	1300	1350	1400	1450	1500	1550	1600	1650	1700	1750	1800
L	466	516	566	616	666	716	766	816	866	916	966	1016	1066	1116	1166	1216	1266	1316	1366	1416	1466	1516	1566	1616	1666	1716	1766	1816	1866	1916	1966	2016	2066	2116	2166
A	100	150	200	50	100	150	200	50	100	150	200	50	100	150	200	50	100	150	200	50	100	150	200	50	100	150	200	50	100	150	200	50	100	150	200
N	6	6	6	8	8	8	8	10	10	10	10	12	12	12	12	14	14	14	14	16	16	16	16	18	18	18	18	20	20	20	20	22	22	22	22
M	1	1	1	1	2	2	2	3	3	3	3	4	4	4	4	5	5	5	5	6	6	6	6	7	7	7	7	8	8	8	8	9	9	9	9
KG	24.1	25.3	26.5	27.7	28.9	30.1	31.3	32.5	33.7	34.9	36.1	37.3	38.5	39.7	40.9	42.1	43.3	44.5	45.7	46.9	48.1	49.3	50.5	51.7	52.9	54.1	55.3	56.5	57.7	58.9	60.1	61.3	62.5	63.7	64.9

如有超长行程及定制需求, 请咨询我司业务。If you have extra long trip and custom requirements, please consult our business.

- HNR
- HCR
- HNB
- HCB
- HNT
- XYZ
- ONB
- OCB
- GCR
- GCB
- GCBS
- GCRS
- ESR
- EMR
- EHR
- KSR
- LNP
- DDR

参考资料
Reference data



重复精度
Repeat Accuracy
±0.02
mm

此图仅供参考, 出货规格详见尺寸图面
This picture for reference only, specs details according with the drawing.

- 最大行程 Max stroke: 2400mm
- 最高速度 Max speed: 1600mm/s
- 马达容量 Motor output: 1000W
- 滚珠螺杆 Ball screw: Ø32mm
- 直线滑轨 Linear guide: 23X18-2支

型号表达方式 Ordering method

TPA-HCR-220D-3210C-L2400-M-Y-P1K-N3-F

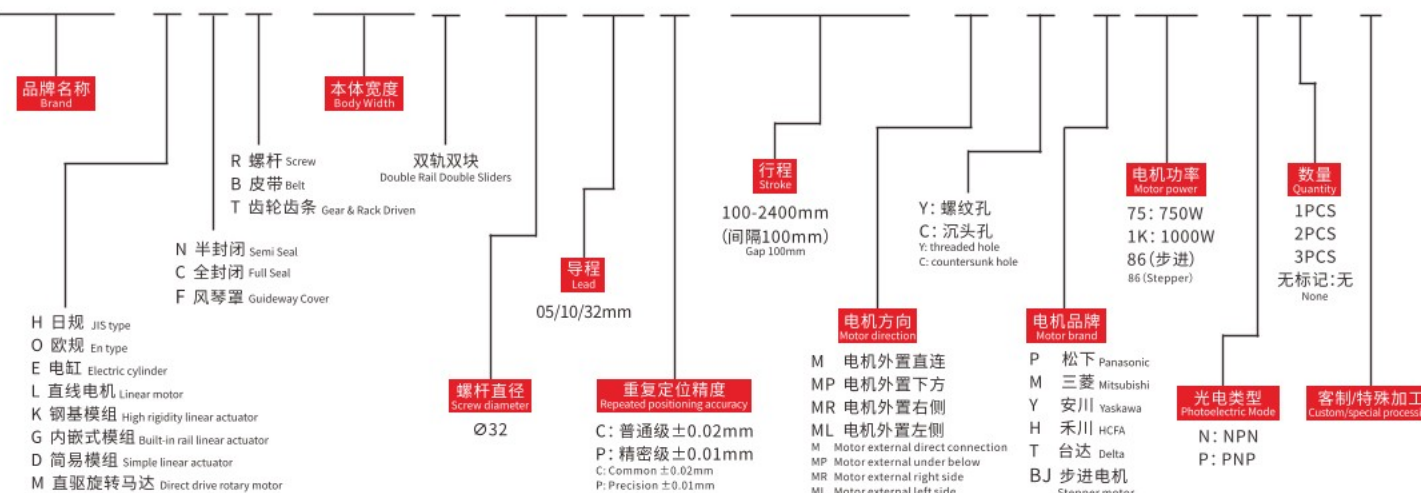

产品性能参数如下 Product performance parameters are as follows

规格 Spec	电机功率 (W) Motor power (W)	1000				
	额定扭矩 (N.M) Rated torque (N.M)	3.2				
	重复定位精度 (mm) Repeated positioning accuracy (mm)	±0.02				
	导程 (mm) Lead (mm)	5	10	20	32	
	最高速度 (mm/s) Maximum speed (mm/s)	250	500	1000	1600	
	电机额定转速 (RPM) Rated speed of motor (RPM)	3000				
	最大可搬重量 Maximum Payload	水平使用 (kg) Horizontal (kg)	180	170	105	66
		垂直使用 (kg) Vertical (kg)	100	80	40	25
	定格推力 (N) Rated thrust (N)	2306	1153	577	461	
	标准行程 (mm) Stroke pitch (mm)	100~2400mm/100 间隔100 mm Pitch				
部品 Parts	滚珠螺杆外径 (mm) Ball screw Ø (mm)	Ø32				
	基座材质 Material of base	硬质挤压铝材A1 Hard extruded aluminum A1				
	安装面精度要求 (mm) Accuracy requirements of installation surface (mm)	C级<0.05; P级<0.02 C level<0.05 P level<0.02				
	使用环境 Operating environment	0~40°C, 85%RH (无凝结) No condensation				

注1: 使用非上述功率电机时请依据实际参数推算。
Note 1: When using a motor with a power other than the above, please calculate according to the actual parameters.
注2: 最高速度因行程和负载而异, 当螺杆细长比大于1:50时, 可能会因螺杆临界速度产生共振和抖动, 应适当下调运行速度, 一般螺杆每增长100mm, 速度应下调10~15%。
Note 2: The maximum speed varies with stroke and load. When the screw slenderness ratio is greater than 1:50, resonance and jitter may occur due to the critical speed of the screw, so the running speed should be reduced appropriately. Generally, the speed should be reduced by 10~15% for every 100mm increase of the screw.

容许负载力矩表 N.m Allowable overhang

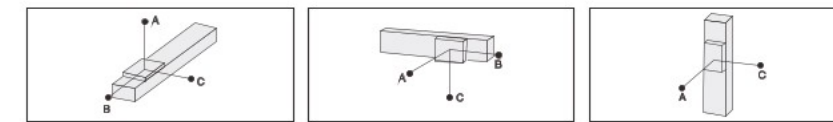

(单位Unit:mm)				(单位Unit:mm)				(单位Unit:mm)			
水平安装 Horizontal installation				侧面安装 Side mounting				垂直安装 Vertical installation			
导程 Lead	A	B	C	导程 Lead	A	B	C	导程 Lead	A	B	C
5	100kg	5000	633	557	110kg	500	569	4500	30kg	2355	2355
	125kg	3880	491	431	130kg	412	469	3711	40kg	1768	1768
10	150kg	3357	396	347	150kg	347	396	3357	55kg	1288	1288
	100kg	3220	563	474	110kg	427	503	2900	25kg	2505	2505
	125kg	3554	434	367	130kg	351	414	2444	35kg	1795	1795
20	150kg	2113	349	295	150kg	295	349	2113	45kg	1396	1396
	65kg	1522	614	458	70kg	420	564	1404	15kg	2711	2711
	85kg	1136	451	336	90kg	315	420	1066	20kg	2033	2033
32	105kg	893	350	262	105kg	262	350	893	-	-	-
	18kg	2445	1616	1052	15kg	1272	1955	2948	7kg	3511	3511
	30kg	1436	938	613	24kg	778	1190	1813	12kg	2055	2055
	43kg	978	630	412	43kg	412	630	978	-	-	-

感应器连接图<原点及端点> Sensor layout

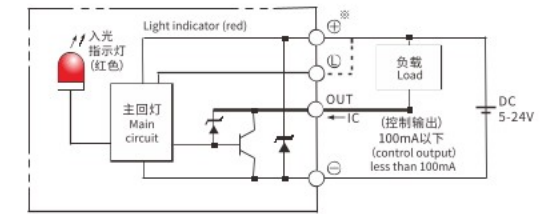

- HNR
- HCR
- HNB
- HCB
- HNT
- XYZ
- ONB
- OCB
- GCR
- GCB
- GCBS
- GCRS
- ESR
- EMR
- EHR
- KSR
- LNP
- DDR
- 参考资料
Reference data

静态容许负载惯量 Static loading moment

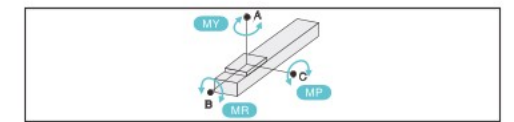

(单位Unit:N.m)	
MY	2052
MP	2052
MR	1810

*力矩表所表示的数据, 代表重心。
The torque value in the chart indicate the center of gravity.
*符合型录规范的正常试用下, 保证寿命为10000公里。
Operation life is 10,000km when the product is using under the specified conditions.
*倒吊使用无法套用标准规范, 如有需求请咨询我司业务。
The standard specification cannot be applied to the use of inverted crane. Please consult our business if necessary.

搭配伺服马达一览表 Suitable motor brand

品牌 Brand	马达记号 Mark	刹车有无 Brake	马达容量 Motor capacity	电源电压 AC-Voltage	伺服马达型号 Servo motor model	驱动器型号 Driver Model
三菱 Mitsubishi	M	无刹车(水平式样) No brake (horizontal type)	200	220	HG-KR73	MR-J4-70A
松下 Panasonic	P	无刹车(水平式样) No brake (horizontal type)	200	220	MHMD082G1U	MBDHT3520
台达 Delta	T	无刹车(水平式样) No brake (horizontal type)	200	220	ECMA-C20807ES	ASD-B20721-B



电机外置直连/电机外置下方
Motor external direct connection/Motor external under below

M 电机外置直连 Motor external direct connection

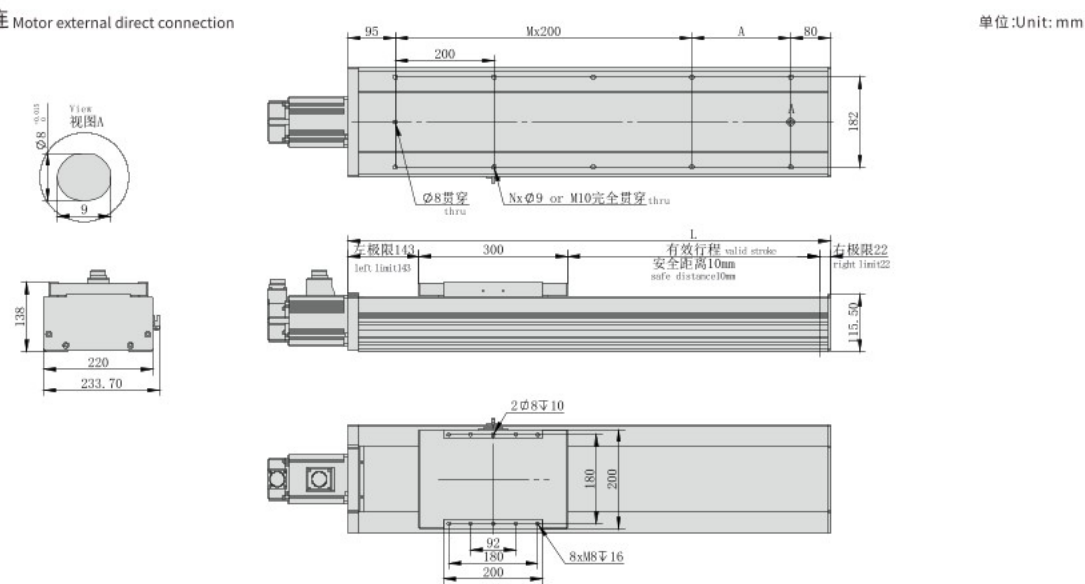

*不含电机重量。*Motor weight not included.

有效行程 Stroke	100	200	300	400	500	600	700	800	900	1000	1100	1200	1300	1400	1500	1600	1700	1800	1900	2000	2100	2200	2300	2400
L	575	675	775	875	975	1075	1175	1275	1375	1475	1575	1675	1775	1875	1975	2075	2175	2275	2375	2475	2575	2675	2775	2875
A	200	100	200	100	200	100	200	100	200	100	200	100	200	100	200	100	200	100	200	100	200	100	200	100
N	6	8	8	10	10	12	12	14	14	16	16	18	18	20	20	22	22	24	24	26	26	28	28	30
M	2	3	3	4	4	5	5	6	6	7	7	8	8	9	9	10	10	11	11	12	12	13	13	14
KG	24.4	27.4	30.4	33.4	36.4	39.4	42.4	45.4	48.4	51.4	54.4	57.4	60.4	63.4	66.4	69.4	72.4	75.4	78.4	81.4	84.4	87.4	90.4	93.4

如有超长行程及定制需求, 请咨询我司业务。If you have extra long trip and custom requirements, please consult our business.

电机外置左侧/电机外置右侧
Motor external left side / Motor external right side

ML 电机外置左侧 Motor external left side

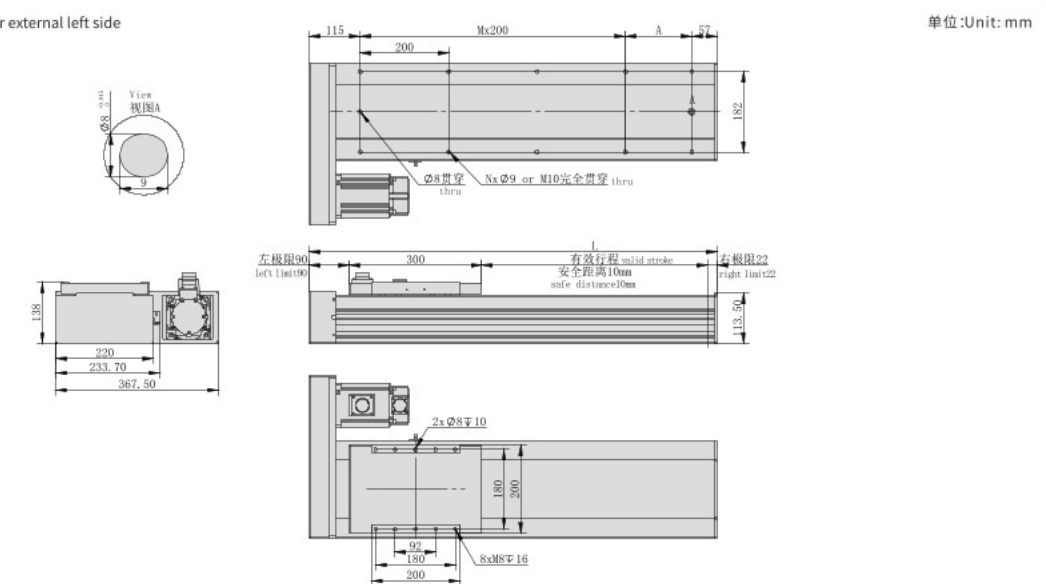

*不含电机重量。*Motor weight not included.

有效行程 Stroke	100	200	300	400	500	600	700	800	900	1000	1100	1200	1300	1400	1500	1600	1700	1800	1900	2000	2100	2200	2300	2400
L	522	622	722	822	922	1022	1122	1222	1322	1422	1522	1622	1722	1822	1922	2022	2122	2222	2322	2422	2522	2622	2722	2822
A	150	50	150	50	150	50	150	50	150	50	150	50	150	50	150	50	150	50	150	50	150	50	150	50
N	6	8	8	10	10	12	12	14	14	16	16	18	18	20	20	22	22	24	24	26	26	28	28	30
M	2	3	3	4	4	5	5	6	6	7	7	8	8	9	9	10	10	11	11	12	12	13	13	14
KG	26.1	29.1	32.1	35.1	38.1	41.1	44.1	47.1	50.1	53.1	56.1	59.1	62.1	65.1	68.1	71.1	74.1	77.1	80.1	83.1	86.1	89.1	92.1	95.1

如有超长行程及定制需求, 请咨询我司业务。If you have extra long trip and custom requirements, please consult our business.

MP 电机外置下方 Motor external under below

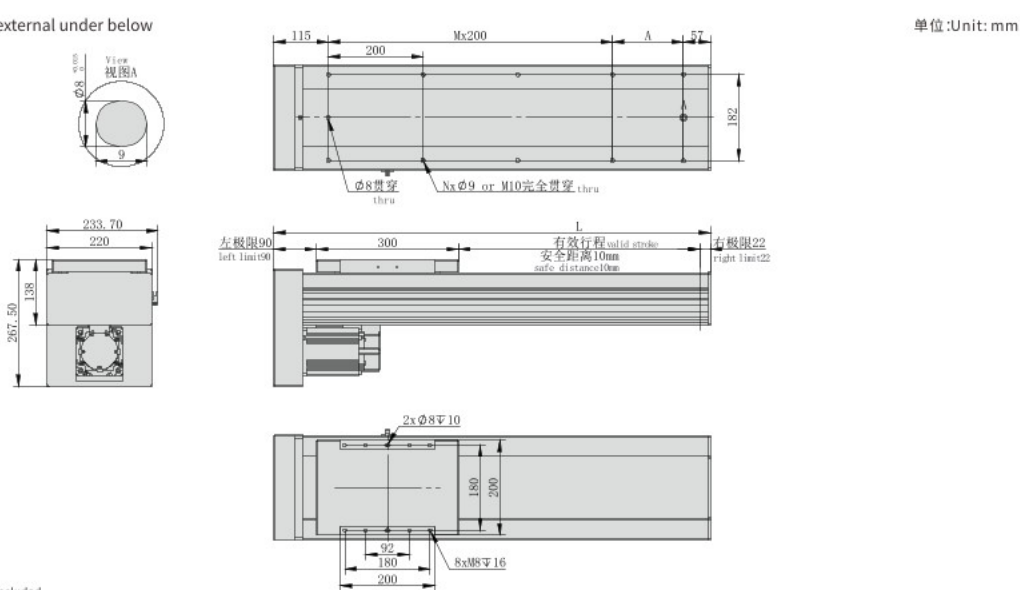

*不含电机重量。*Motor weight not included.

有效行程 Stroke	100	200	300	400	500	600	700	800	900	1000	1100	1200	1300	1400	1500	1600	1700	1800	1900	2000	2100	2200	2300	2400
L	522	622	722	822	922	1022	1122	1222	1322	1422	1522	1622	1722	1822	1922	2022	2122	2222	2322	2422	2522	2622	2722	2822
A	150	50	150	50	150	50	150	50	150	50	150	50	150	50	150	50	150	50	150	50	150	50	150	50
N	6	8	8	10	10	12	12	14	14	16	16	18	18	20	20	22	22	24	24	26	26	28	28	30
M	2	3	3	4	4	5	5	6	6	7	7	8	8	9	9	10	10	11	11	12	12	13	13	14
KG	26.1	29.1	32.1	35.1	38.1	41.1	44.1	47.1	50.1	53.1	56.1	59.1	62.1	65.1	68.1	71.1	74.1	77.1	80.1	83.1	86.1	89.1	92.1	95.1

如有超长行程及定制需求, 请咨询我司业务。If you have extra long trip and custom requirements, please consult our business.

MR 电机外置右侧 Motor external right side

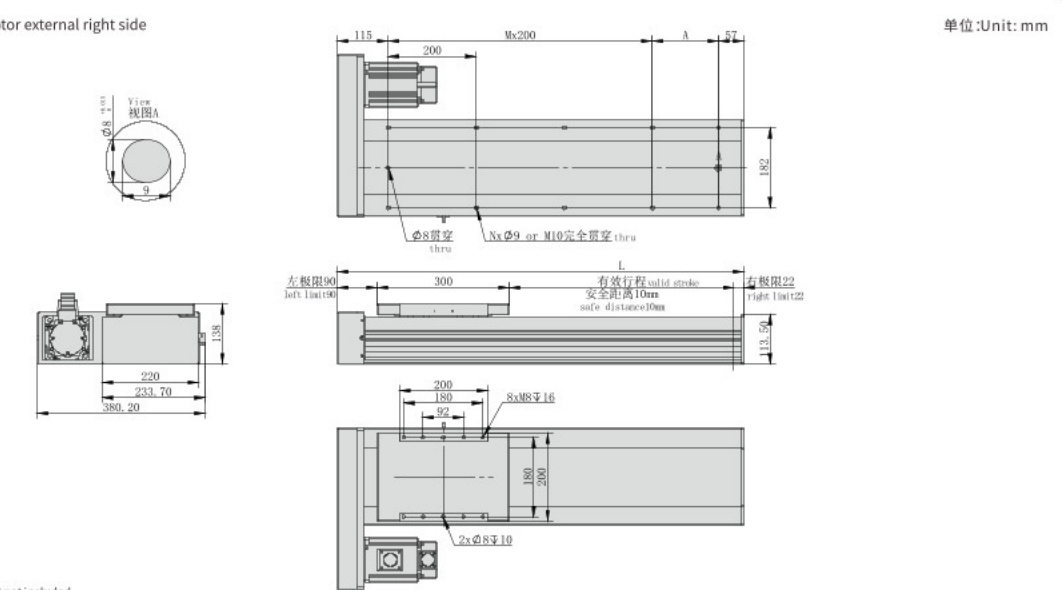

*不含电机重量。*Motor weight not included.

有效行程 Stroke	100	200	300	400	500	600	700	800	900	1000	1100	1200	1300	1400	1500	1600	1700	1800	1900	2000	2100	2200	2300	2400
L	522	622	722	822	922	1022	1122	1222	1322	1422	1522	1622	1722	1822	1922	2022	2122	2222	2322	2422	2522	2622	2722	2822
A	150	50	150	50	150	50	150	50	150	50	150	50	150	50	150	50	150	50	150	50	150	50	150	50
N	6	8	8	10	10	12	12	14	14	16	16	18	18	20	20	22	22	24	24	26	26	28	28	30
M	2	3	3	4	4	5	5	6	6	7	7	8	8	9	9	10	10	11	11	12	12	13	13	14
KG	26.1	29.1	32.1	35.1	38.1	41.1	44.1	47.1	50.1	53.1	56.1	59.1	62.1	65.1	68.1	71.1	74.1	77.1	80.1	83.1	86.1	89.1	92.1	95.1

如有超长行程及定制需求, 请咨询我司业务。If you have extra long trip and custom requirements, please consult our business.

- HNR
- HCR
- HNB
- HCB
- HNT
- XYZ
- ONB
- OCB
- GCR
- GCB
- GCBS
- GCRS
- ESR
- EMR
- EHR
- KSR
- LNP
- DDR

参考资料
Reference data

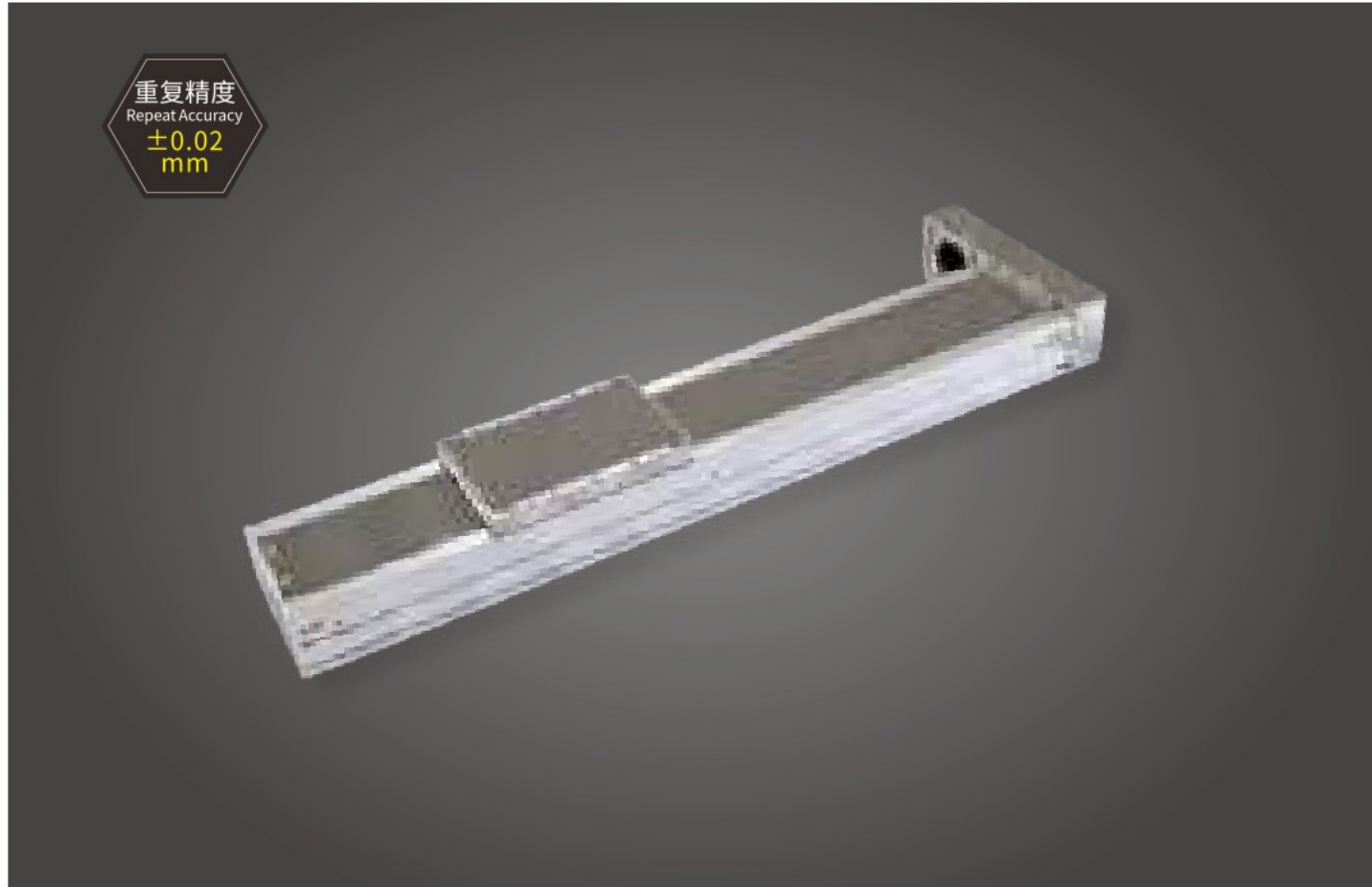

重复精度
Repeat Accuracy
±0.02
mm

此图仅供参考, 出货规格详见尺寸图面
This picture for reference only, specs details according with the drawing.

- 最大行程 Max stroke: 3000mm
- 最高速度 Max speed: 2000mm/s
- 马达容量 Motor output: 1000W
- 滚珠螺杆 Ball screw: Ø40mm
- 直线滑轨 Linear guide: 23X18-2支

型号表达方式 Ordering method

TPA-HCR-270D-4010C-L3000-M-Y-P1K-N3-F

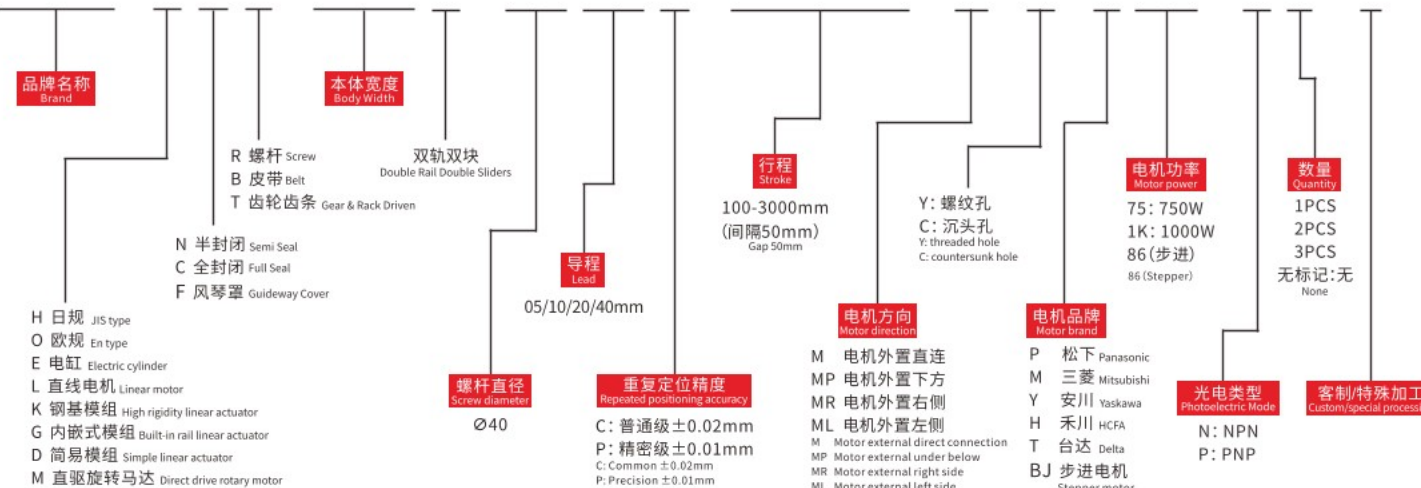

产品性能参数如下 Product performance parameters are as follows

规格 Spec	电机功率(W) Motor power (W)	1000			
	额定扭矩(N.M) Rated torque (N.M)	3.2			
	重复定位精度(mm) Repeated positioning accuracy (mm)	±0.02			
	导程(mm) Lead (mm)	5	10	20	40
	最高速度(mm/s) Maximum speed (mm/s)	250	500	1000	2000
	电机额定转速(RPM) Rated speed of motor (RPM)	3000			
最大可搬重量 Maximum Payload	水平使用(kg) Horizontal (kg)	230	200	125	78
	垂直使用(kg) Vertical (kg)	115	95	48	30
定格推力(N) Rated thrust (N)	3195	1598	499	1598	
标准行程(mm) Stroke pitch (mm)	100~3000mm/50mm间隔 50mm Pitch				
部品 Parts	滚珠螺杆外径(mm) Ball screw Ø (mm)	Ø40			
	基座材质 Material of base	硬质挤压铝材A1 Hard extruded aluminum A1			
	安装面精度要求(mm) Accuracy requirements of installation surface (mm)	C级<0.05; P级<0.02 C level<0.05 P level<0.02			
	使用环境 Operating environment	0~40°C, 85%RH(无凝结) No condensation			

注1: 使用非上述功率电机时请依据实际参数推算。
Note 1: When using a motor with a power other than the above, please calculate according to the actual parameters.
注2: 最高速度因行程和负载而异, 当螺杆细长比大于1:50时, 可能会因螺杆临界速度产生共振和抖动, 应适当下调运行速度, 一般螺杆每增长100mm, 速度应下调10~15%。
Note 2: The maximum speed varies with stroke and load. When the screw slenderness ratio is greater than 1:50, resonance and jitter may occur due to the critical speed of the screw, so the running speed should be reduced appropriately. Generally, the speed should be reduced by 10~15% for every 100mm increase of the screw.

容许负载力矩表 N.m Allowable overhang

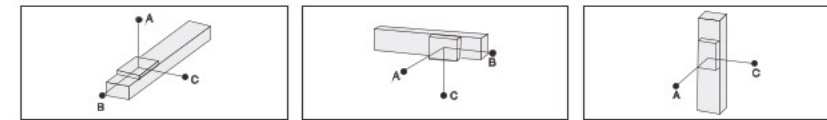

(单位Unit:mm)				(单位Unit:mm)				(单位Unit:mm)			
水平安装 Horizontal installation	A	B	C	侧面安装 Side mounting	A	B	C	垂直安装 Vertical installation	A	C	
导程 5 Lead	150kg	1367	542	408	150kg	1368	541	410	64kg	980	980
	180kg	1079	293	227	180kg	1080	293	229	80kg	670	670
	200kg	906	102	82	200kg	906	101	84	115kg	222	222
导程 10 Lead	130kg	1496	772	605	130kg	1495	770	605	56kg	1811	1811
	150kg	1237	513	403	150kg	1236	513	403	70kg	1153	1153
	180kg	1020	248	190	180kg	1021	245	190	84kg	714	714
导程 20 Lead	90kg	1450	920	768	90kg	1451	922	766	35kg	1270	1270
	100kg	1217	573	453	100kg	1215	573	456	40kg	877	877
	125kg	937	395	308	125kg	937	395	307	48kg	754	754
导程 40 Lead	45kg	1010	602	482	45kg	1009	605	484	20kg	1170	1175
	60kg	835	395	223	60kg	836	395	225	25kg	890	891
	78kg	524	243	192	78kg	527	246	191	30kg	531	533

传感器连接图<原点及端点> Sensor layout

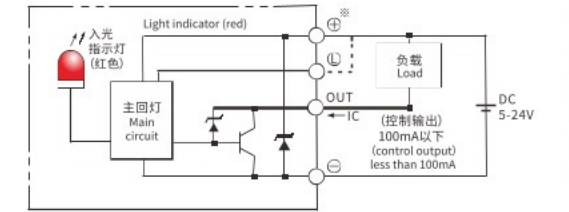

静态容许负载惯量 Static loading moment

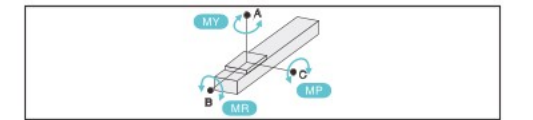

(单位Unit:N.m)	
MY	3223
MP	3223
MR	2843

*力矩表所表示的数据, 代表重心。
The torque value in the chart indicate the center of gravity.
*符合型录规范的正常试用下, 保证寿命为10000公里。
Operation life is 10,000km when the product is using under the specified conditions.
*倒吊使用无法套用标准规范, 如有需求请咨询我司业务。
The standard specification cannot be applied to the use of inverted crane. Please consult our business if necessary.

搭配伺服马达一览表 Suitable motor brand

品牌 Brand	马达记号 Mark	刹车有无 Brake	马达容量 Motor capacity	电源电压 AC-Voltage	伺服马达型号 Servo motor model	驱动器型号 Driver Model
三菱 Mitsubishi	M	无刹车(水平式样) No brake (horizontal type)	200	220	HG-KR73	MR-J4-70A
松下 Panasonic	P	无刹车(水平式样) No brake (horizontal type)	200	220	MHMD082G1U	MBDHT3520
台达 Delta	T	无刹车(水平式样) No brake (horizontal type)	200	220	ECMA-C20807ES	ASD-B20721-B

