



重复精度
Repeat Accuracy
±0.04
mm

此图仅供参考, 出货规格详见尺寸图面
This picture for reference only, specs details according with the drawing.

最大行程
Max stroke 1800mm

最高速度
Max speed 4500mm/s

马达容量
Motor output 100W

直线滑轨
Linear guide 42X9.5-1支

型号表达方式 Ordering method

TPA-HCB-65S-90-L1800-MR-Y-P10-N3-F

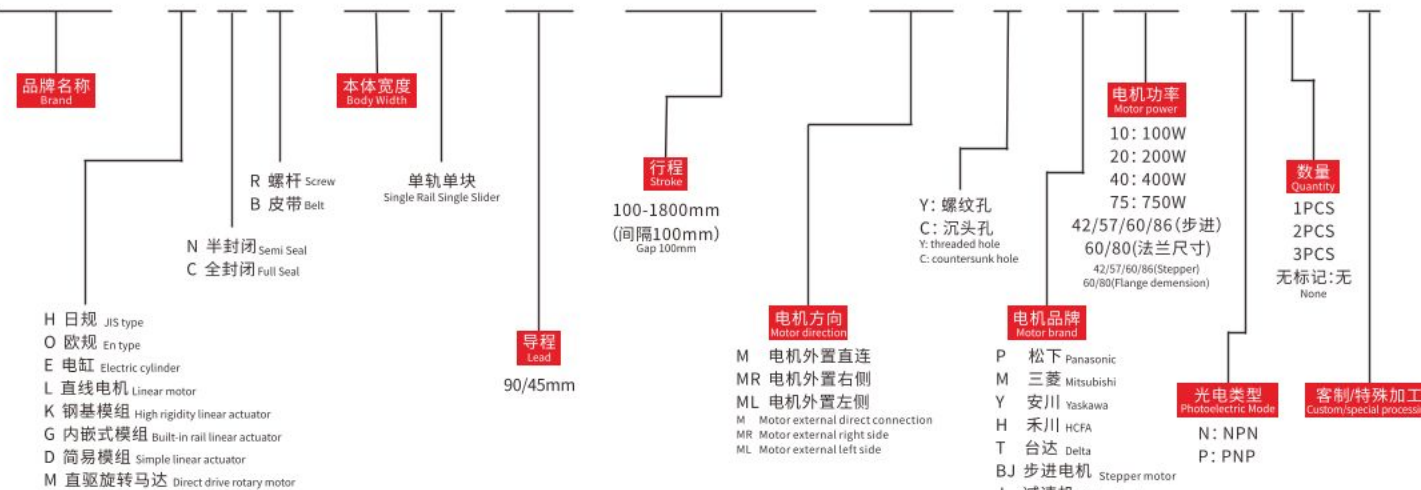

产品性能参数如下 Product performance parameters are as follows

规格 Spec	电机功率 (W) Motor power (W)	100	
	重复定位精度 (mm) Repeated positioning accuracy (mm)	±0.04	
	减速比 (mm) Reduction ratio	1:1	1:2
	导程 (mm) Lead (mm)	90	45
	最高速度 (mm/s) Maximum speed (mm/s)	4500	
	电机额定转速 (RPM) Rated speed of motor (RPM)	3000	
部 品 Parts	最大可搬重量 Maximum Payload	4	8
	标准行程 (mm) Stroke pitch (mm)	100~1800mm/100 间隔 100 mm Pitch	
部 品 Parts	底座材质 Material of base	不锈钢/合金钢 Stainless steel/alloy steel	
	使用环境 Operating environment	0~40°C, 85%RH (无凝结) No condensation	

注1: 使用非上述功率电机时请依据实际参数推算。
Note 1: When using a motor with a power other than the above, please calculate according to the actual parameters.

注2: 最高速度因行程和负载而异, 当螺杆细长比大于1:50时, 可能会因螺杆临界速度产生共振和抖动, 应适当下调运行速度, 一般螺杆每增长100mm, 速度应下调10~15%。
Note 2: The maximum speed varies with stroke and load. When the screw slenderness ratio is greater than 1:50, resonance and jitter may occur due to the critical speed of the screw, so the running speed should be reduced appropriately. Generally, the speed should be reduced by 10~15% for every 100mm increase of the screw.

容许负载力矩表 N.m Allowable overhang

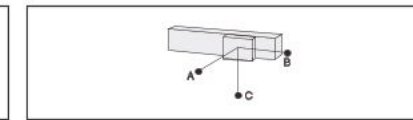
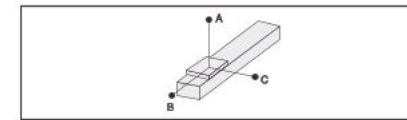

负载 Load	水平安装 Horizontal installation			侧面安装 Side mounting			
	A	B	C	A	B	C	
5kg	620	65	165	5kg	151	59	582
10kg	253	29	73	10kg	66	26	532
15kg	126	16	42	15kg	38	15	111

传感器连接图<原点及端点> Sensor layout

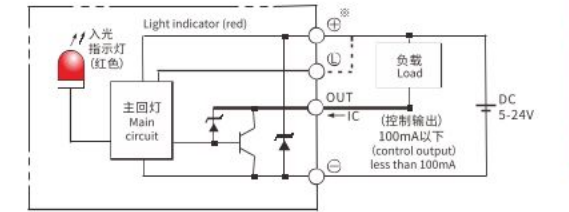

静态容许负载惯量 Static loading moment

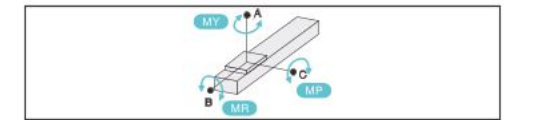

MY	MP	MR
16	20	19

*力矩表所表示的数据, 代表重心。
The torque value in the chart indicate the center of gravity.
*符合型录规范的正常试用下, 保证寿命为10000公里。
Operation life is 10,000km when the product is using under the specified conditions.
*侧吊使用无法套用标准规范, 如有需求请咨询我司业务。
The standard specification cannot be applied to the use of inverted crane. Please consult our business if necessary.

搭配伺服马达一览表 Suitable motor brand

品牌 Brand	马达记号 Mark	刹车有无 Brake	马达容量 Motor capacity	电源电压 AC-Voltage	伺服马达型号 Servo motor model	驱动器型号 Driver Model
三菱 Mitsubishi	M	无刹车(水平式样) No brake (horizontal type)	200	220	HG-KR73	MR-J4-70A
松下 Panasonic	P	无刹车(水平式样) No brake (horizontal type)	200	220	MHMD082G1U	MBDHT3520
台达 Delta	T	无刹车(水平式样) No brake (horizontal type)	200	220	ECMA-C20807ES	ASD-B20721-B



电机外置直连/电机外置左侧
Motor external direct connection/Motor external left side

M 电机外置直连 Motor external direct connection

单位:Unit: mm

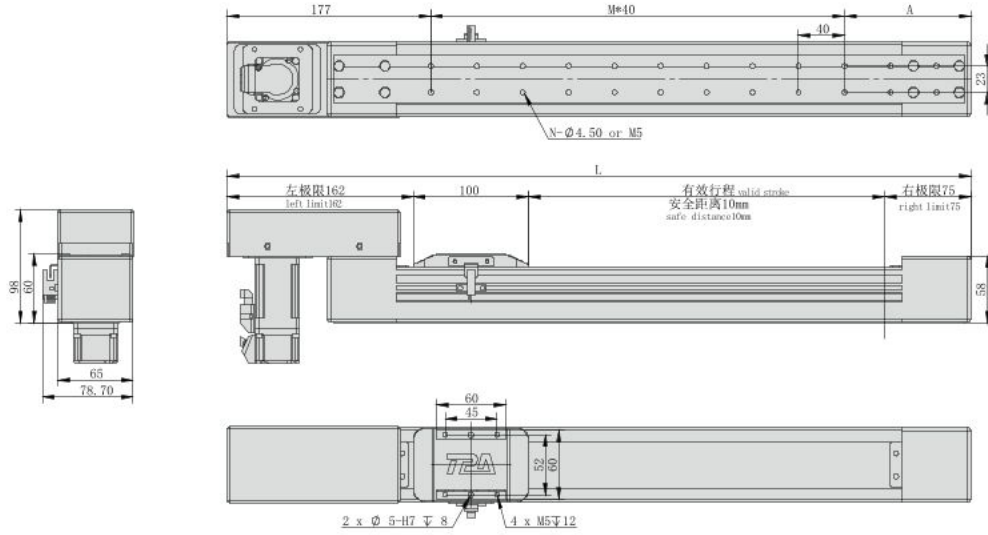

*不含电机重量。*Motor weight not included.

有效行程 Stroke	100	200	300	400	500	600	700	800	900	1000	1100	1200	1300	1400	1500	1600	1700	1800
L	447	547	647	747	847	947	1047	1147	1247	1347	1447	1547	1647	1747	1847	1947	2047	2147
A	110	90	110	90	110	90	110	90	110	90	110	90	110	90	110	90	110	90
N	10	16	20	26	30	36	40	46	50	56	60	66	70	76	80	86	90	96
M	4	7	9	12	14	17	19	22	24	27	29	32	34	37	39	42	44	47
KG	2.3	2.7	3.1	3.5	3.9	4.3	4.7	5.1	5.5	5.9	6.3	6.7	7.1	7.5	7.9	8.3	8.7	9.1

如有超长行程及定制需求, 请咨询我司业务。If you have extra long trip and custom requirements, please consult our business.

电机外置右侧
Motor external right side

MR 电机外置右侧 Motor external right side

单位:Unit: mm

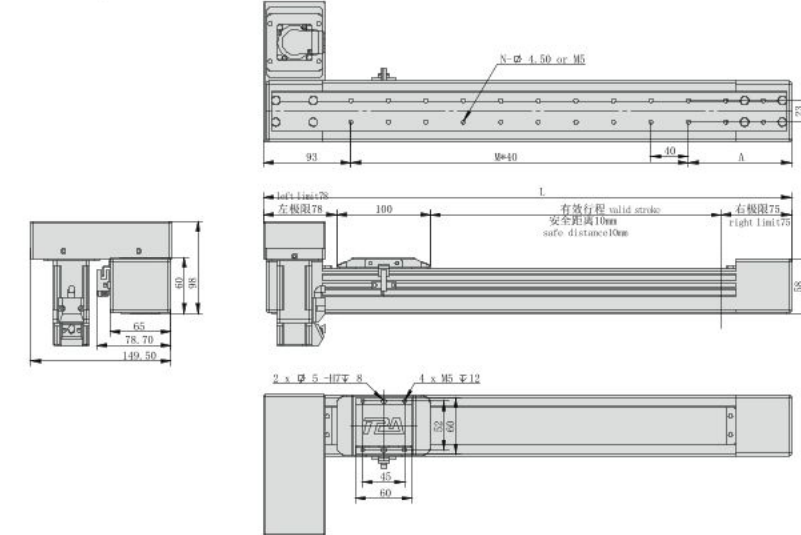

*不含电机重量。*Motor weight not included.

有效行程 Stroke	100	200	300	400	500	600	700	800	900	1000	1100	1200	1300	1400	1500	1600	1700	1800
L	363	463	563	663	763	863	963	1063	1163	1263	1363	1463	1563	1663	1763	1863	1963	2063
A	110	90	110	90	110	90	110	90	110	90	110	90	110	90	110	90	110	90
N	10	16	20	26	30	36	40	46	50	56	60	66	70	76	80	86	90	96
M	4	7	9	12	14	17	19	22	24	27	29	32	34	37	39	42	44	47
KG	2.3	2.7	3.1	3.5	3.9	4.3	4.7	5.1	5.5	5.9	6.3	6.7	7.1	7.5	7.9	8.3	8.7	9.1

如有超长行程及定制需求, 请咨询我司业务。If you have extra long trip and custom requirements, please consult our business.

ML 电机外置左侧 Motor external left side

单位:Unit: mm

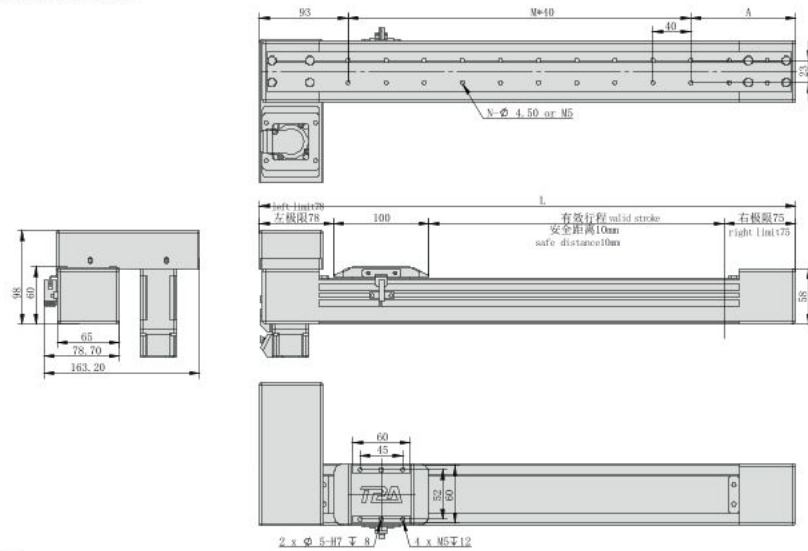

*不含电机重量。*Motor weight not included.

有效行程 Stroke	100	200	300	400	500	600	700	800	900	1000	1100	1200	1300	1400	1500	1600	1700	1800
L	363	463	563	663	763	863	963	1063	1163	1263	1363	1463	1563	1663	1763	1863	1963	2063
A	110	90	110	90	110	90	110	90	110	90	110	90	110	90	110	90	110	90
N	10	16	20	26	30	36	40	46	50	56	60	66	70	76	80	86	90	96
M	4	7	9	12	14	17	19	22	24	27	29	32	34	37	39	42	44	47
KG	2.3	2.7	3.1	3.5	3.9	4.3	4.7	5.1	5.5	5.9	6.3	6.7	7.1	7.5	7.9	8.3	8.7	9.1

如有超长行程及定制需求, 请咨询我司业务。If you have extra long trip and custom requirements, please consult our business.

- HNR
- HCR
- HNB
- HCB
- HNT
- XYZ
- ONB
- OCB
- GCR
- GCB
- GCBS
- GCRS
- ESR
- EMR
- EHR
- KSR
- LNP
- DDR

参考资料
Reference data



重复精度
Repeat Accuracy
 ± 0.04
mm

此图仅供参考, 出货规格详见尺寸图
This picture for reference only, specs details according with the drawing.

最大行程
Max stroke 1050mm

最高速度
Max speed 4500mm/s

马达容量
Motor output 200W

直线滑轨
Linear guide 9X6.5-2支

型号表达方式 Ordering method

TPA-HCB-85D-90-L1050-MR-Y-P10-N3-F

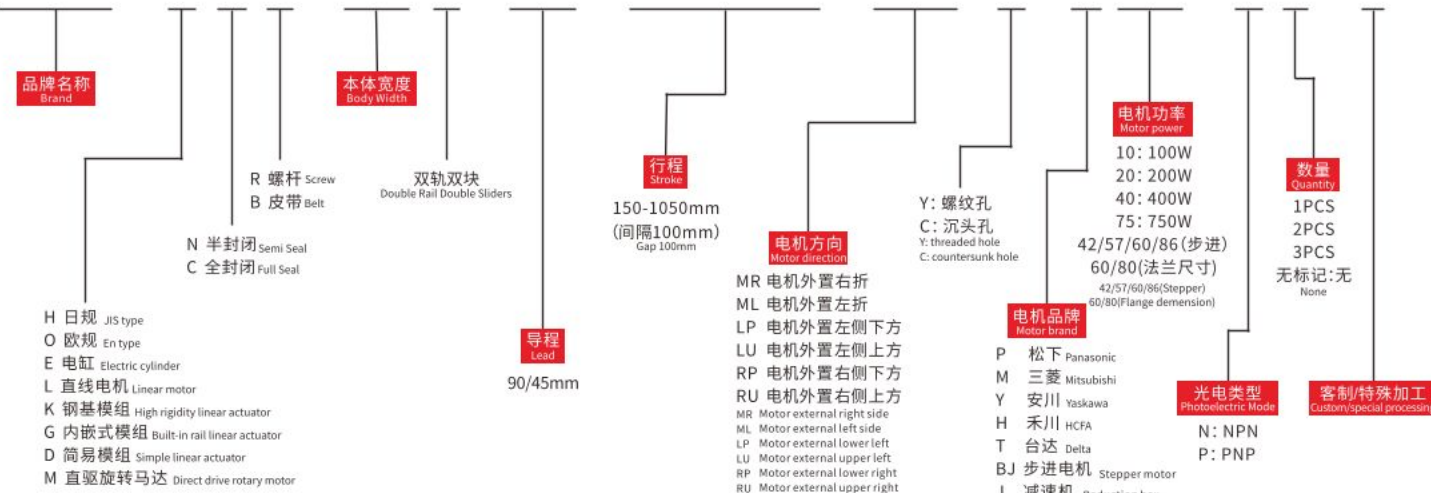

产品性能参数如下 Product performance parameters are as follows

规格 Spec	电机功率 (W) Motor power (W)	200	
	重复定位精度 (mm) Repeated positioning accuracy (mm)	± 0.04	
	减速比 (mm) Reduction ratio	1:1	1:2
	导程 (mm) Lead (mm)	90	45
	最高速度 (mm/s) Maximum speed (mm/s)	4500	
	电机额定转速 (RPM) Rated speed of motor (RPM)	3000	
部 品 Parts	最大可搬重量 Maximum Payload	7	14
	标准行程 (mm) Stroke pitch (mm)	150~1050mm/100 间隔100 mm Pitch	
部 品 Parts	基座材质 Material of base	硬质挤压铝材A1 Hard extruded aluminum A1	
	使用环境 Operating environment	0~40°C, 85%RH(无凝结) No condensation	

注1: 使用非上述功率电机时请依据实际参数推算。
Note 1: When using a motor with a power other than the above, please calculate according to the actual parameters.

注2: 最高速度因行程和负载而异, 当螺杆细长比大于1:50时, 可能会因螺杆临界速度产生共振和抖动, 应适当下调运行速度, 一般螺杆每增长100mm, 速度应下调10~15%。
Note 2: The maximum speed varies with stroke and load. When the screw slenderness ratio is greater than 1:50, resonance and jitter may occur due to the critical speed of the screw, so the running speed should be reduced appropriately. Generally, the speed should be reduced by 10~15% for every 100mm increase of the screw.

传感器连接图<原点及端点> Sensor layout

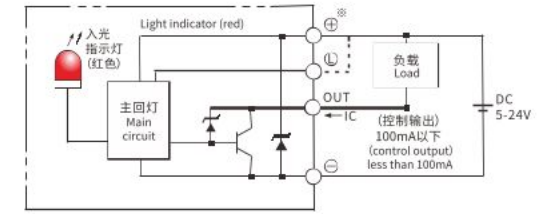

容许负载力矩表 N.m Allowable overhang

负载 Load	水平安装 Horizontal installation			侧面安装 Side mounting		
	A	B	C	A	B	C
5kg	630	410	271	5kg	255	290
13kg	300	188	61	13kg	88	95
20kg	195	102	-	20kg	-	-

静态容许负载惯量 Static loading moment

惯量	值 (N.m)
MY	80
MP	80
MR	90

*力矩表所表示的数据, 代表重心。
The torque value in the chart indicate the center of gravity.

*符合型录规范的正常试用下, 保证寿命为10000公里。
Operation life is 10,000km when the product is using under the specified conditions.

*侧吊使用无法套用标准规范, 如有需求请咨询我司业务。
The standard specification cannot be applied to the use of inverted crane. Please consult our business if necessary.

搭配伺服马达一览表 Suitable motor brand

品牌 Brand	马达记号 Mark	刹车有无 Brake	马达容量 Motor capacity	电源电压 AC-Voltage	伺服马达型号 Servo motor model	驱动器型号 Driver Model
三菱 Mitsubishi	M	无刹车(水平式样) No brake (horizontal type)	200	220	HG-KR73	MR-J4-70A
松下 Panasonic	P	无刹车(水平式样) No brake (horizontal type)	200	220	MHMD082G1U	MBDHT3520
台达 Delta	T	无刹车(水平式样) No brake (horizontal type)	200	220	ECMA-C20807ES	ASD-B20721-B



电机外置左侧/电机外置右侧
Motor external left side / Motor external right side

ML 电机外置左侧 Motor external left side

单位:Unit: mm

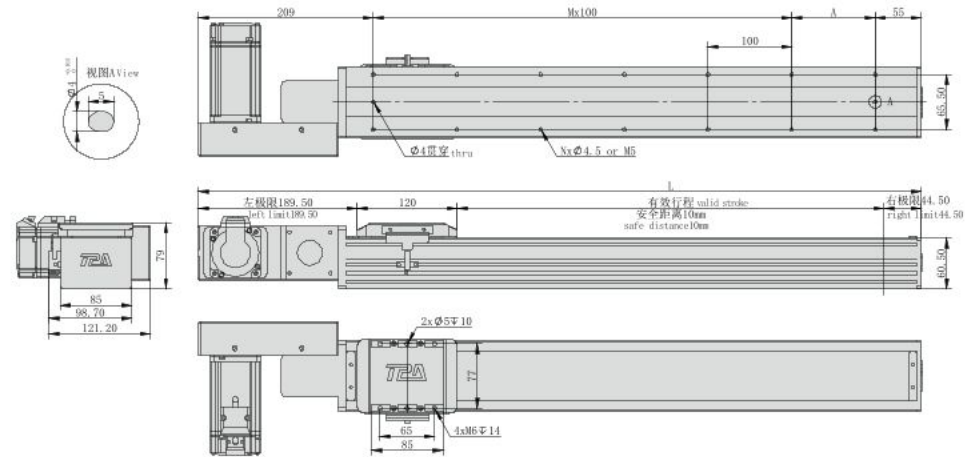

*不含电机重量。*Motor weight not included.

有效行程 Stroke	150	250	350	450	550	650	750	850	950	1050
L	514	614	714	814	914	1014	1114	1214	1314	1414
A	50	50	50	50	50	50	50	50	50	50
N	8	10	12	14	16	18	20	22	24	26
M	2	3	4	5	6	7	8	9	10	11
KG	4.7	5.2	5.7	6.2	6.7	7.2	7.7	8.2	8.7	9.2

如有超长行程及定制需求,请咨询我司业务。If you have extra long trip and custom requirements, please consult our business.

电机外置左下/电机外置左上
Motor external lower left / Motor external upper left

LP 电机外置左下 Motor external lower left

单位:Unit: mm

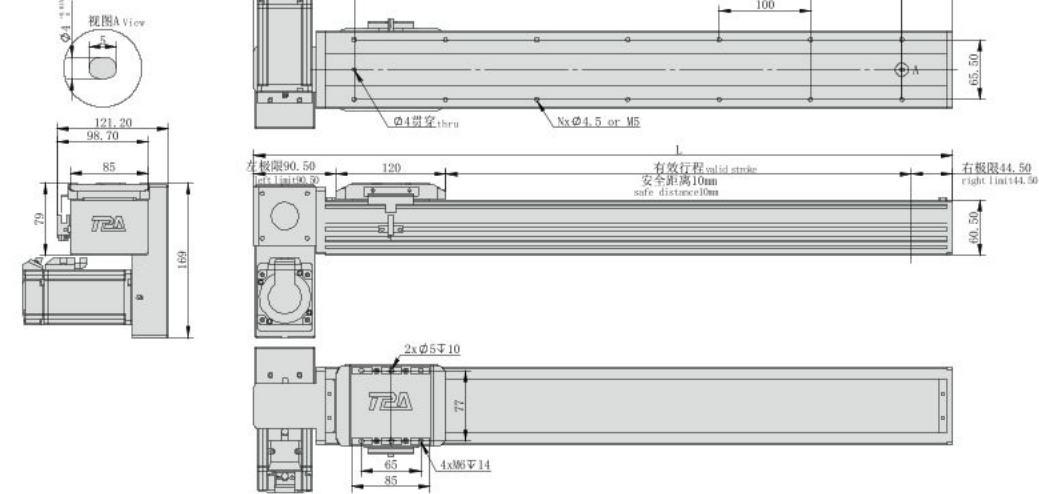

*不含电机重量。*Motor weight not included.

有效行程 Stroke	150	250	350	450	550	650	750	850	950	1050
L	415	515	615	715	815	915	1015	1115	1215	1315
A	50	50	50	50	50	50	50	50	50	50
N	8	10	12	14	16	18	20	22	24	26
M	2	3	4	5	6	7	8	9	10	11
KG	4.7	5.2	5.7	6.2	6.7	7.2	7.7	8.2	8.7	9.2

如有超长行程及定制需求,请咨询我司业务。If you have extra long trip and custom requirements, please consult our business.

MR 电机外置右侧 Motor external right side

单位:Unit: mm

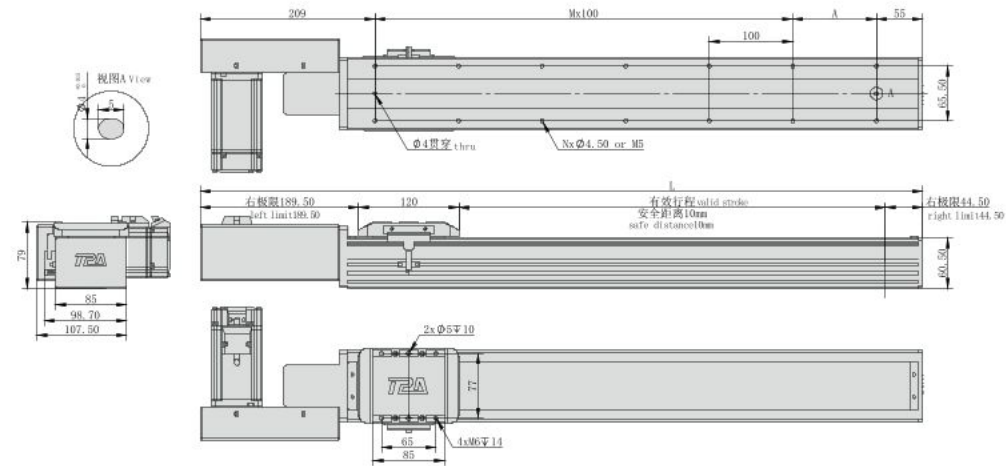

*不含电机重量。*Motor weight not included.

有效行程 Stroke	150	250	350	450	550	650	750	850	950	1050
L	514	614	714	814	914	1014	1114	1214	1314	1414
A	50	50	50	50	50	50	50	50	50	50
N	8	10	12	14	16	18	20	22	24	26
M	2	3	4	5	6	7	8	9	10	11
KG	4.7	5.2	5.7	6.2	6.7	7.2	7.7	8.2	8.7	9.2

如有超长行程及定制需求,请咨询我司业务。If you have extra long trip and custom requirements, please consult our business.

LU 电机外置左上 Motor external upper left

单位:Unit: mm

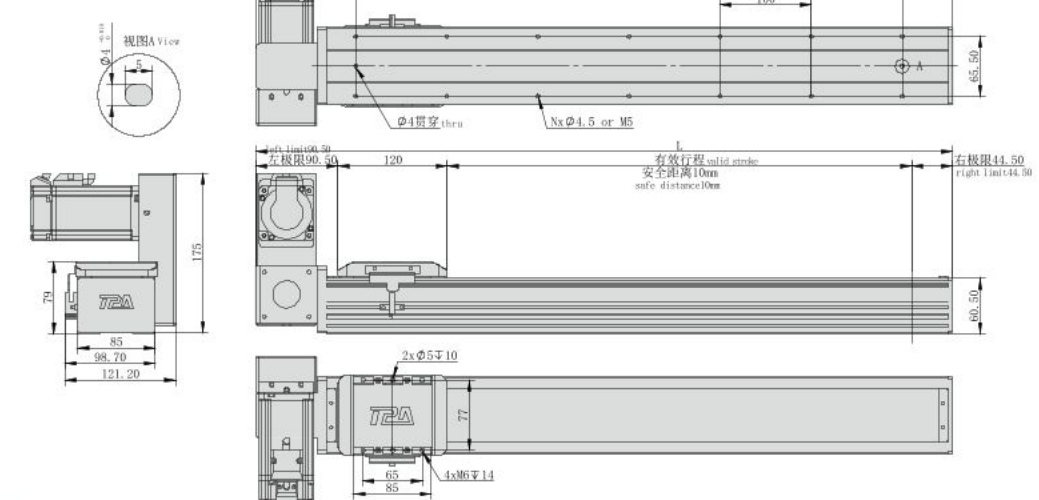

*不含电机重量。*Motor weight not included.

有效行程 Stroke	150	250	350	450	550	650	750	850	950	1050
L	415	515	615	715	815	915	1015	1115	1215	1315
A	50	50	50	50	50	50	50	50	50	50
N	8	10	12	14	16	18	20	22	24	26
M	2	3	4	5	6	7	8	9	10	11
KG	4.7	5.2	5.7	6.2	6.7	7.2	7.7	8.2	8.7	9.2

如有超长行程及定制需求,请咨询我司业务。If you have extra long trip and custom requirements, please consult our business.

- HNR
- HCR
- HNB
- HCB
- HNT
- XYZ
- ONB
- OCB
- GCR
- GCB
- GCBS
- GCRS
- ESR
- EMR
- EHR
- KSR
- LNP
- DDR
- 参考资料
Reference data



电机外置右下/电机外置右上
Motor external lower right / Motor external upper right

RP 电机外置右下 Motor external lower right

单位:Unit: mm

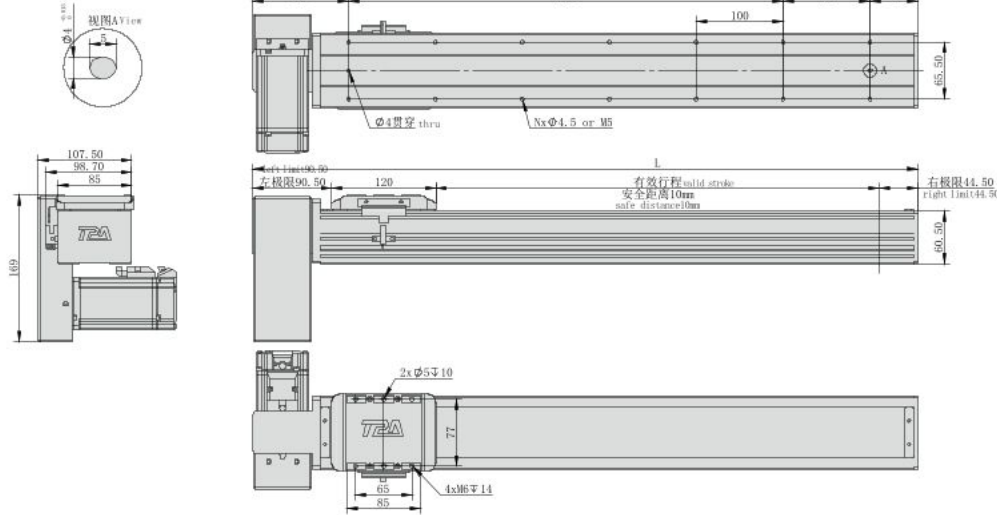

*不含电机重量。*Motor weight not included.

有效行程 Stroke	150	250	350	450	550	650	750	850	950	1050
L	415	515	615	715	815	915	1015	1115	1215	1315
A	50	50	50	50	50	50	50	50	50	50
N	8	10	12	14	16	18	20	22	24	26
M	2	3	4	5	6	7	8	9	10	11
KG	4.7	5.2	5.7	6.2	6.7	7.2	7.7	8.2	8.7	9.2

如有超长行程及定制需求, 请咨询我司业务。If you have extra long trip and custom requirements, please consult our business.

RU 电机外置右上 Motor external upper right

单位:Unit: mm

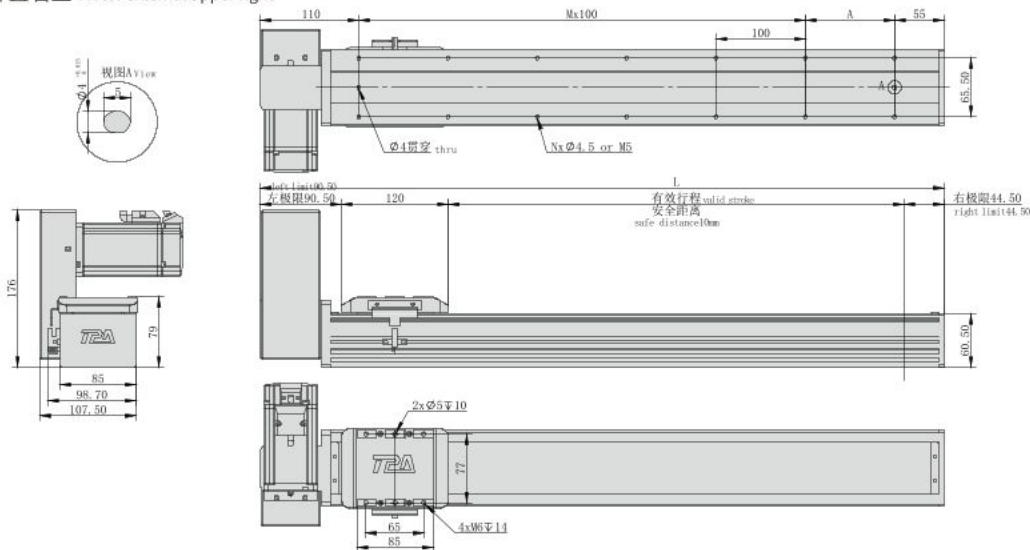

*不含电机重量。*Motor weight not included.

有效行程 Stroke	150	250	350	450	550	650	750	850	950	1050
L	415	515	615	715	815	915	1015	1115	1215	1315
A	50	50	50	50	50	50	50	50	50	50
N	8	10	12	14	16	18	20	22	24	26
M	2	3	4	5	6	7	8	9	10	11
KG	4.7	5.2	5.7	6.2	6.7	7.2	7.7	8.2	8.7	9.2

如有超长行程及定制需求, 请咨询我司业务。If you have extra long trip and custom requirements, please consult our business.

知识小课堂 Knowledge classroom

日规模组原理 Theory of Asia Standard Linear Actuator

伺服滑台是一种将伺服马达、滚珠螺杆(或同步带、齿轮齿条)、导轨等相结合的一种小型设备, 通过电机旋转运动来驱动传动结构转换成直线运动, 从而实现高精度、高速度、高负载的直线运行工作。

Servo slide table is a kind of small equipment which combines servo motor, ball screw (or synchronous belt, rack and pinion) and guide rail. The transmission structure is converted into linear motion through the rotary motion of the motor, so as to realize high-precision, high-speed and high-load linear operation.

日规模组特点 Feature of Asia Standard Linear Actuator

伺服滑台作为一款小型集成设备有着许多特点, 精度高、重复定位精度最高可达 $\pm 0.008\text{mm}$, 运行速度快、可以采用螺杆、同步带及齿轮齿条等传动方式, 安装方便、可在恶劣的工作环境下无故障运行; 本体质量轻、占设备空间小, 高刚性、寿命长、噪音低、控制简单、维护方便等。

As a small integrated equipment, the servo slide table has many characteristics, such as high precision, repeated positioning accuracy up to $\pm 0.01\text{mm}$, fast running speed, convenient installation and trouble-free operation in harsh working environment. Light weight, small equipment space, high rigidity, long service life, low noise, simple control and convenient maintenance.

日规模组产品优势 Product advantage of Asia Standard Linear Actuator

1. 传动结构多样化 Diversification of transmission structure

作为一款小型集成设备, 滑台在结构方面既简单又有着多样的选择性, 目前广泛使用的可分为三类型, 滚珠螺杆型、同步带型以及齿轮齿条形式, 可适用于不同的工作环境。

As a small integrated equipment, the sliding table is simple in structure and has a variety of options. At present, it can be widely used in three types: ball screw type, synchronous belt type and rack and pinion type, which can be applied to different working environments.

2. 控制简单、适用性强 Simple control and strong applicability

由伺服、步进等电机驱动, 既有着伺服电机的高精度、也有滑台本身高速度、高刚性的优势, 操控简单可轻易与PLC等系统连接。

Driven by servo, stepper and other motors, it not only has the high precision of servo motor, but also has the advantages of high speed and high rigidity of sliding table itself. It is easy to control and can be easily connected with PLC and other systems.

3. 安装便捷、尺寸可非标化 Convenient installation and nonstandard size

滑台采用的是一体挤压成型铝型材, 本体质量轻、尺寸小、刚性强、安装尺寸、行程都可以按要求非标定制, 安装使用螺栓固定便可。

The sliding table is made of integrally extruded aluminum profile, with light weight, small size and strong rigidity. The installation size and stroke can be customized according to the requirements, and the installation can be fixed by bolts.

4. 组合搭建 Combined construction

滑台可通过多放向的组合, 组成设备上的运动执行机构, 例如工业机械手XYZ轴机械手、坐标轴滑台等。

The sliding table can be combined with multiple directions to form the motion executing mechanism on the equipment, such as XYZ axis manipulator, coordinate axis sliding table and so on.

HNR
HCR
HNB
HCB
HNT
XYZ
ONB
OCB
GCR
GCB
GCBS
GCRS
ESR
EMR
EHR
KSR
LNP
DDR
参考资料
Reference data



重复精度
Repeat Accuracy
±0.04
mm

此图仅供参考, 出货规格详见尺寸图面
This picture for reference only, specs details according with the drawing.

最大行程
Max stroke 3050mm

最高速度
Max speed 4500mm/s

马达容量
Motor output 200W

直线滑轨
Linear guide 20X18-2支

型号表达方式 Ordering method

TPA-HCB-105D-90-L3050-MR-Y-P20-N3-F

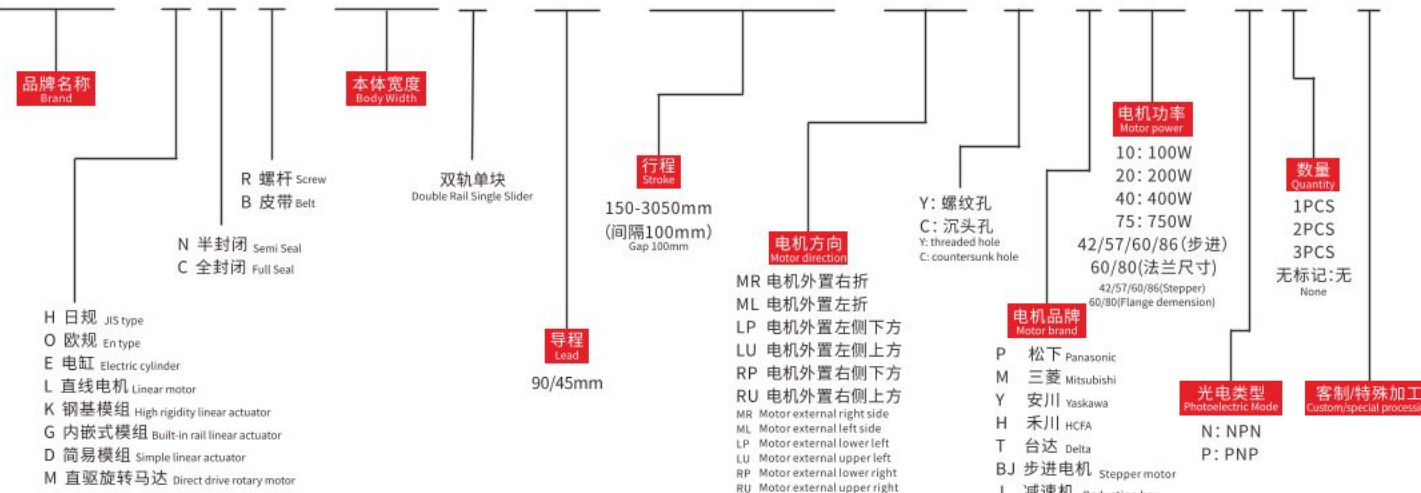

产品性能参数如下 Product performance parameters are as follows

规格 Spec	电机功率 (W) Motor power (W)	200	
	重复定位精度 (mm) Repeated positioning accuracy (mm)	±0.04	
	减速比 (mm) Reduction ratio	1:1	1:2
	导程 (mm) Lead (mm)	90	45
	最高速度 (mm/s) Maximum speed (mm/s)	4500	
	电机额定转速 (RPM) Rated speed of motor (RPM)	3000	
部 品 Parts	最大可搬重量 Maximum Payload	9	18
	标准行程 (mm) Stroke pitch (mm)	150~3050mm/100 间隔100 mm Pitch	
	基座材质 Material of base	硬质挤压铝材A1 Hard extruded aluminum A1	
使用环境 Operating environment	0~40°C, 85%RH(无凝结) No condensation		

注1: 使用非上述功率电机时请依据实际参数推算。
Note 1: When using a motor with a power other than the above, please calculate according to the actual parameters.
注2: 最高速度因行程和负载而异, 当螺杆细长比大于1:50时, 可能会因螺杆临界速度产生共振和抖动, 应适当下调运行速度, 一般螺杆每增长100mm, 速度应下调10~15%。
Note 2: The maximum speed varies with stroke and load. When the screw slenderness ratio is greater than 1:50, resonance and jitter may occur due to the critical speed of the screw, so the running speed should be reduced appropriately. Generally, the speed should be reduced by 10~15% for every 100mm increase of the screw.

传感器连接图<原点及端点> Sensor layout

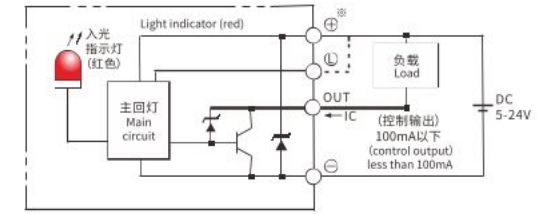

容许负载力矩表 N.m Allowable overhang

(单位Unit:mm)				(单位Unit:mm)			
水平安装 Horizontal installation	A	B	C	侧面安装 Side mounting	A	B	C
5kg	495	152	128	4kg	162	192	625
8kg	301	91	77	7kg	89	106	347
10kg	236	71	60	10kg	60	71	236

静态容许负载惯量 Static loading moment

(单位Unit:N.m)	
MY	150
MP	150
MR	130

*力矩表所表示的数据, 代表重心。
The torque value in the chart indicate the center of gravity.
*符合型录规范的正常试用下, 保证寿命为10000公里。
Operation life is 10,000km when the product is using under the specified conditions.
*侧吊使用无法套用标准规范, 如有需求请咨询我司业务。
The standard specification cannot be applied to the use of inverted crane. Please consult our business if necessary.

搭配伺服马达一览表 Suitable motor brand

品牌 Brand	马达记号 Mark	刹车有无 Brake	马达容量 Motor capacity	电源电压 AC-Voltage	伺服马达型号 Servo motor model	驱动器型号 Driver Model
三菱 Mitsubishi	M	无刹车(水平式样) No brake (horizontal type)	200	220	HG-KR73	MR-J4-70A
松下 Panasonic	P	无刹车(水平式样) No brake (horizontal type)	200	220	MHMD082G1U	MBDHT3520
台达 Delta	T	无刹车(水平式样) No brake (horizontal type)	200	220	ECMA-C20807ES	ASD-B20721-B

电机外置左侧/电机外置右侧
Motor external left side / Motor external right side

ML 电机外置左侧 Motor external left side

单位:Unit: mm

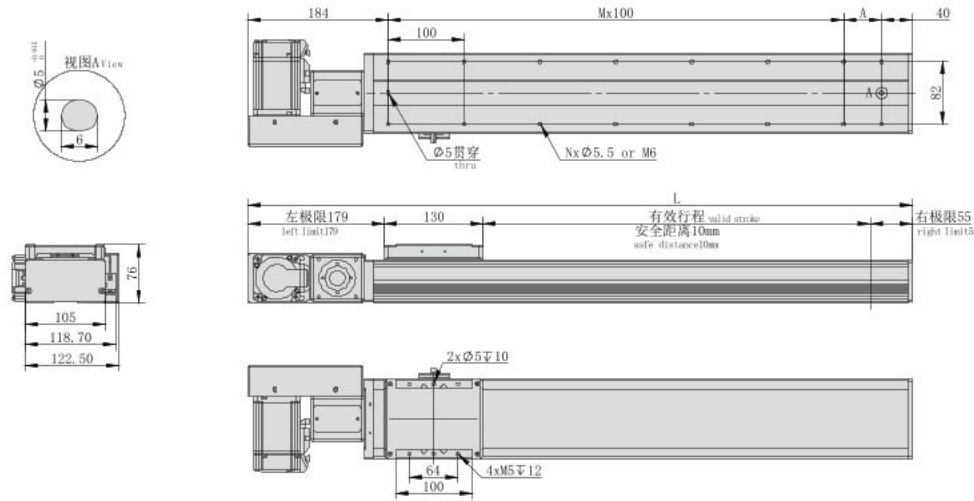

*不含电机重量。*Motor weight not included.

有效行程 Stroke	150	250	350	450	550	650	750	850	950	1050	1150	1250	1350	1450	1550	1650	1750	1850	1950	2050	2150	2250	2350	2450	2550	2650	2750	2850	2950	3050
L	449	549	649	749	849	949	1049	1149	1249	1349	1449	1549	1649	1749	1849	1949	2049	2149	2249	2349	2449	2549	2649	2749	2849	2949	3049	3149	3249	3349
A	100	100	100	100	100	100	100	100	100	100	100	100	100	100	100	100	100	100	100	100	100	100	100	100	100	100	100	100	100	100
N	8	10	12	14	16	18	20	22	24	26	28	30	32	34	36	38	40	42	44	46	48	50	52	54	56	58	60	62	64	66
M	3	4	5	6	7	8	9	10	11	12	13	14	15	16	17	18	19	20	21	22	23	24	25	26	27	28	29	30	31	32
KG	4.8	5.5	6.2	6.9	7.6	8.3	9	9.7	10.4	11.1	11.8	12.5	13.2	13.9	14.6	15.3	16	16.7	17.4	18.1	18.8	19.5	20.2	20.9	21.6	22.3	23	23.7	24.4	25.1

如有超长行程及定制需求, 请咨询我司业务。If you have extra long trip and custom requirements, please consult our business.

MR 电机外置右侧 Motor external right side

单位:Unit: mm

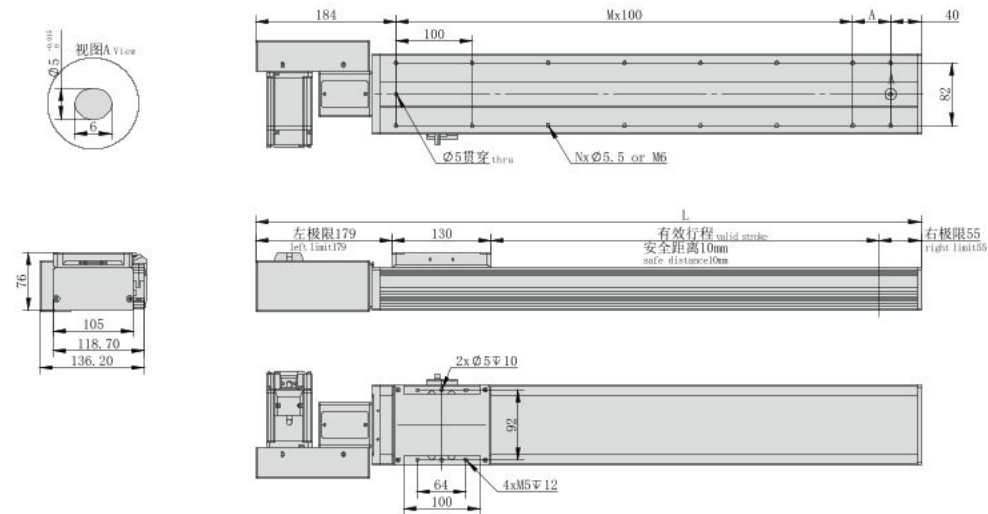

*不含电机重量。*Motor weight not included.

有效行程 Stroke	150	250	350	450	550	650	750	850	950	1050	1150	1250	1350	1450	1550	1650	1750	1850	1950	2050	2150	2250	2350	2450	2550	2650	2750	2850	2950	3050
L	449	549	649	749	849	949	1049	1149	1249	1349	1449	1549	1649	1749	1849	1949	2049	2149	2249	2349	2449	2549	2649	2749	2849	2949	3049	3149	3249	3349
A	100	100	100	100	100	100	100	100	100	100	100	100	100	100	100	100	100	100	100	100	100	100	100	100	100	100	100	100	100	100
N	8	10	12	14	16	18	20	22	24	26	28	30	32	34	36	38	40	42	44	46	48	50	52	54	56	58	60	62	64	66
M	3	4	5	6	7	8	9	10	11	12	13	14	15	16	17	18	19	20	21	22	23	24	25	26	27	28	29	30	31	32
KG	4.8	5.5	6.2	6.9	7.6	8.3	9	9.7	10.4	11.1	11.8	12.5	13.2	13.9	14.6	15.3	16	16.7	17.4	18.1	18.8	19.5	20.2	20.9	21.6	22.3	23	23.7	24.4	25.1

如有超长行程及定制需求, 请咨询我司业务。If you have extra long trip and custom requirements, please consult our business.

电机外置左下/电机外置左上
Motor external lower left / Motor external upper left

LP 电机外置左下 Motor external lower left

单位:Unit: mm

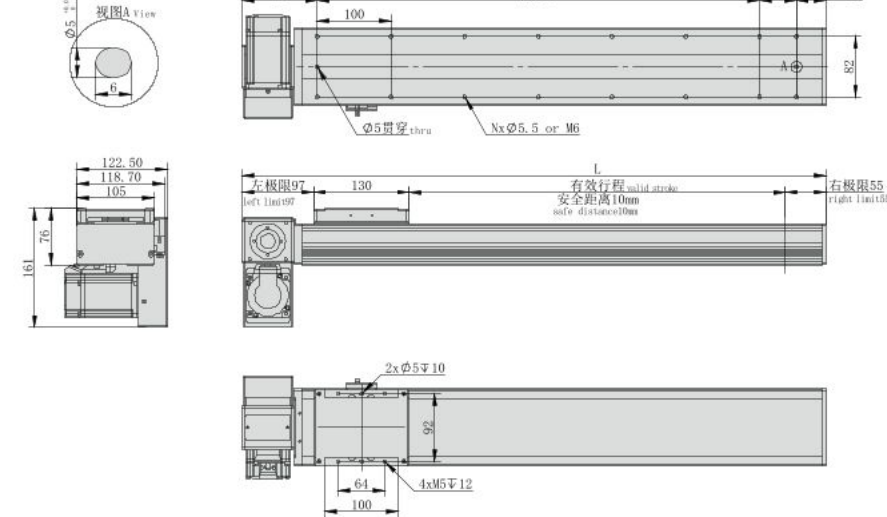

*不含电机重量。*Motor weight not included.

有效行程 Stroke	150	250	350	450	550	650	750	850	950	1050	1150	1250	1350	1450	1550	1650	1750	1850	1950	2050	2150	2250	2350	2450	2550	2650	2750	2850	2950	3050
L	531	631	731	831	931	1031	1131	1231	1331	1431	1531	1631	1731	1831	1931	2031	2131	2231	2331	2431	2531	2631	2731	2831	2931	3031	3131	3231	3331	3431
A	100	100	100	100	100	100	100	100	100	100	100	100	100	100	100	100	100	100	100	100	100	100	100	100	100	100	100	100	100	100
N	8	10	12	14	16	18	20	22	24	26	28	30	32	34	36	38	40	42	44	46	48	50	52	54	56	58	60	62	64	66
M	3	4	5	6	7	8	9	10	11	12	13	14	15	16	17	18	19	20	21	22	23	24	25	26	27	28	29	30	31	32
KG	4.8	5.5	6.2	6.9	7.6	8.3	9	9.7	10.4	11.1	11.8	12.5	13.2	13.9	14.6	15.3	16	16.7	17.4	18.1	18.8	19.5	20.2	20.9	21.6	22.3	23	23.7	24.4	25.1

如有超长行程及定制需求, 请咨询我司业务。If you have extra long trip and custom requirements, please consult our business.

LU 电机外置左上 Motor external upper left

单位:Unit: mm

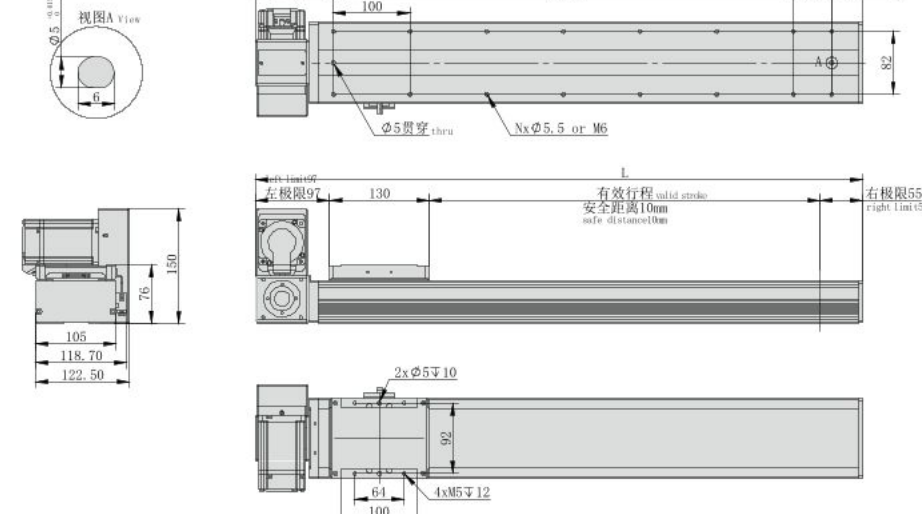

*不含电机重量。*Motor weight not included.

有效行程 Stroke	150	250	350	450	550	650	750	850	950	1050	1150	1250	1350	1450	1550	1650	1750	1850	1950	2050	2150	2250	2350	2450	2550	2650	2750	2850	2950	3050
L	531	631	731	831	931	1031	1131	1231	1331	1431	1531	1631	1731	1831	1931	2031	2131	2231	2331	2431	2531	2631	2731	2831	2931	3031	3131	3231	3331	3431
A	100	100	100	100	100	100	100	100	100	100	100	100	100	100	100	100	100	100	100	100	100	100	100	100	100	100	100	100	100	100
N	8	10	12	14	16	18	20	22	24	26	28	30	32	34	36	38	40	42	44	46	48	50	52	54	56	58	60	62	64	66
M	3	4	5	6	7	8	9	10	11	12	13	14	15	16	17	18	19	20	21	22	23	24	25	26	27	28	29	30	31	32
KG	4.8	5.5	6.2	6.9	7.6	8.3	9	9.7	10.4	11.1	11.8	12.5	13.2	13.9	14.6	15.3	16	16.7	17.4	18.1	18.8	19.5	20.2	20.9	21.6	22.3	23	23.7	24.4	25.1

如有超长行程及定制需求, 请咨询我司业务。If you have extra long trip and custom requirements, please consult our business.

HNR
HCR
HNB
HCB
HNT
XYZ
ONB
OCB
GCR
GCB
GCBS
GCRS
ESR
EMR
EHR
KSR
LNP
DDR

参考资料
Reference
data



电机外置右下/电机外置右上
Motor external lower right / Motor external upper right

RP 电机外置右下 Motor external lower right

单位:Unit: mm

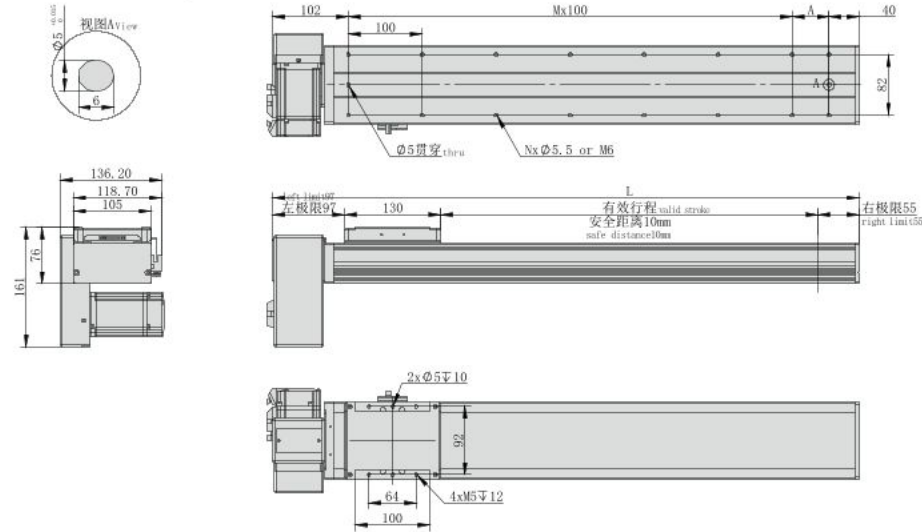

*不含电机重量。*Motor weight not included.

有效行程 Stroke	150	250	350	450	550	650	750	850	950	1050	1150	1250	1350	1450	1550	1650	1750	1850	1950	2050	2150	2250	2350	2450	2550	2650	2750	2850	2950	3050
L	531	631	731	831	931	1031	1131	1231	1331	1431	1531	1631	1731	1831	1931	2031	2131	2231	2331	2431	2531	2631	2731	2831	2931	3031	3131	3231	3331	3431
A	100	100	100	100	100	100	100	100	100	100	100	100	100	100	100	100	100	100	100	100	100	100	100	100	100	100	100	100	100	100
N	8	10	12	14	16	18	20	22	24	26	28	30	32	34	36	38	40	42	44	46	48	50	52	54	56	58	60	62	64	66
M	3	4	5	6	7	8	9	10	11	12	13	14	15	16	17	18	19	20	21	22	23	24	25	26	27	28	29	30	31	32
KG	4.8	5.5	6.2	6.9	7.6	8.3	9	9.7	10.4	11.1	11.8	12.5	13.2	13.9	14.6	15.3	16	16.7	17.4	18.1	18.8	19.5	20.2	20.9	21.6	22.3	23	23.7	24.4	25.1

如有超长行程及定制需求, 请咨询我司业务。 If you have extra long trip and custom requirements, please consult our business.

RU 电机外置右上 Motor external upper right

单位:Unit: mm

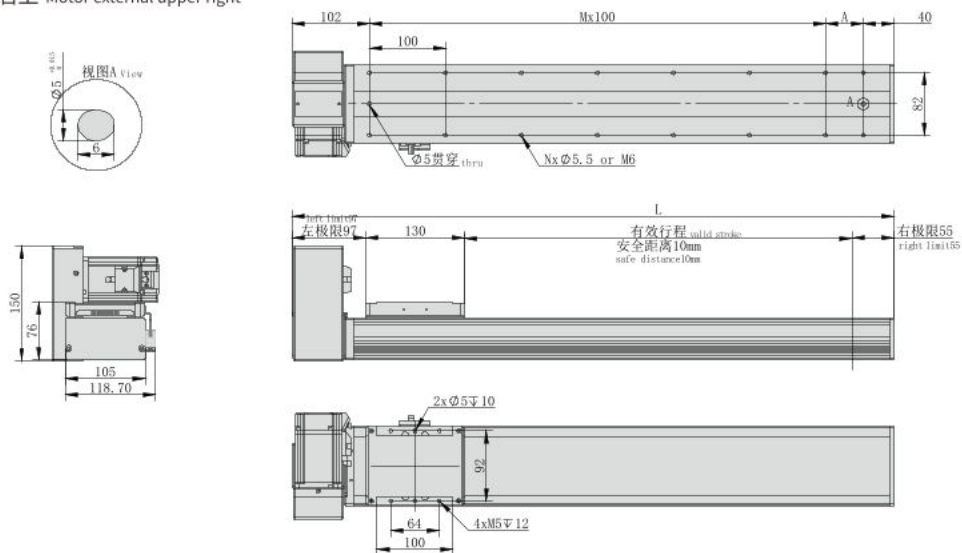

*不含电机重量。*Motor weight not included.

有效行程 Stroke	150	250	350	450	550	650	750	850	950	1050	1150	1250	1350	1450	1550	1650	1750	1850	1950	2050	2150	2250	2350	2450	2550	2650	2750	2850	2950	3050
L	531	631	731	831	931	1031	1131	1231	1331	1431	1531	1631	1731	1831	1931	2031	2131	2231	2331	2431	2531	2631	2731	2831	2931	3031	3131	3231	3331	3431
A	100	100	100	100	100	100	100	100	100	100	100	100	100	100	100	100	100	100	100	100	100	100	100	100	100	100	100	100	100	100
N	8	10	12	14	16	18	20	22	24	26	28	30	32	34	36	38	40	42	44	46	48	50	52	54	56	58	60	62	64	66
M	3	4	5	6	7	8	9	10	11	12	13	14	15	16	17	18	19	20	21	22	23	24	25	26	27	28	29	30	31	32
KG	4.8	5.5	6.2	6.9	7.6	8.3	9	9.7	10.4	11.1	11.8	12.5	13.2	13.9	14.6	15.3	16	16.7	17.4	18.1	18.8	19.5	20.2	20.9	21.6	22.3	23	23.7	24.4	25.1

如有超长行程及定制需求, 请咨询我司业务。 If you have extra long trip and custom requirements, please consult our business.

MEMO

- HNR
- HCR
- HNB
- HC B
- HNT
- XYZ
- ONB
- OCB
- GCR
- GCB
- GCBS
- GCRS
- ESR
- EMR
- EHR
- KSR
- LNP
- DDR

参考资料
Reference
data



重复精度
Repeat Accuracy
±0.04
mm

此图仅供参考, 出货规格详见尺寸图面
This picture for reference only, specs details according with the drawing.

最大行程
Max stroke 1850mm

最高速度
Max speed 4500mm/s

马达容量
Motor output 200W

直线滑轨
Linear guide 12X8-2支

型号表达方式 Ordering method

TPA-HCB-110D-90-L1850-MR-Y-P20-N3-F

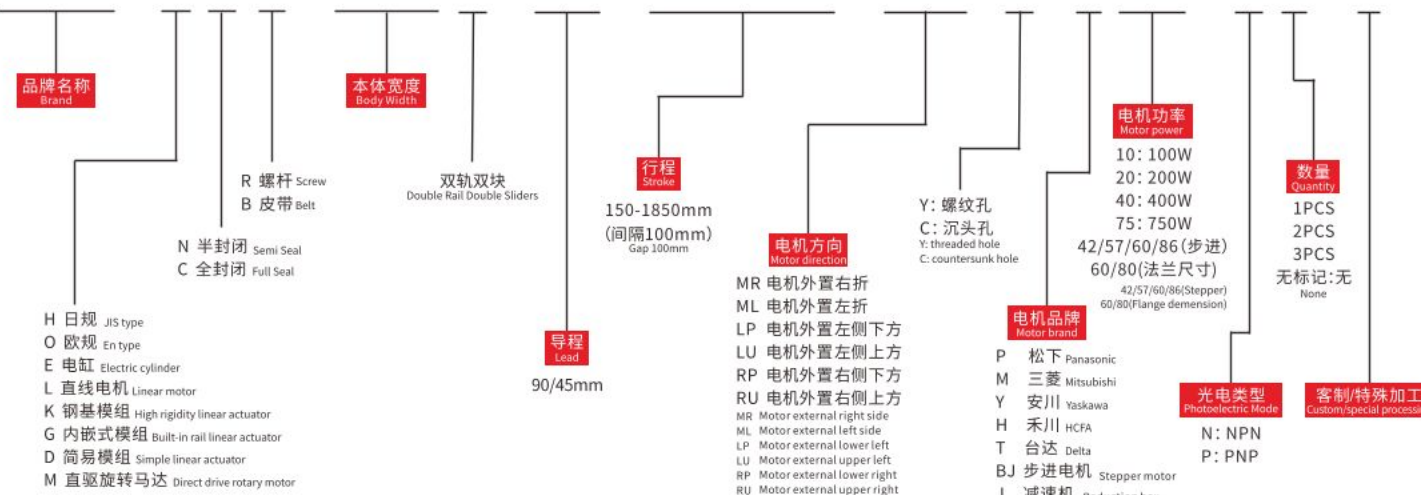

产品性能参数如下 Product performance parameters are as follows

规格 Spec	电机功率 (W) Motor power (W)	200	
	重复定位精度 (mm) Repeated positioning accuracy (mm)	±0.04	
	减速比 (mm) Reduction ratio	1:1	1:2
	导程 (mm) Lead (mm)	90	45
	最高速度 (mm/s) Maximum speed (mm/s)	4500	
	电机额定转速 (RPM) Rated speed of motor (RPM)	3000	
部 品 Parts	最大可搬重量 Maximum Payload	9	18
	标准行程 (mm) Stroke pitch (mm)	150~1850mm/100 间隔100 mm Pitch	
	基座材质 Material of base	硬质挤压铝材A1 Hard extruded aluminum A1	
使用环境 Operating environment	0~40°C, 85%RH(无凝结) No condensation		

注1: 使用非上述功率电机时请依据实际参数推算。
Note 1: When using a motor with a power other than the above, please calculate according to the actual parameters.

注2: 最高速度因行程和负载而异, 当螺杆细长比大于1:50时, 可能会因螺杆临界速度产生共振和抖动, 应适当下调运行速度, 一般螺
杆每增长100mm, 速度应下调10~15%。
Note 2: The maximum speed varies with stroke and load. When the screw slenderness ratio is greater than 1:50, resonance and jitter
may occur due to the critical speed of the screw, so the running speed should be reduced appropriately. Generally, the speed
should be reduced by 10~15% for every 100mm increase of the screw.

容许负载力矩表 N.m Allowable overhang

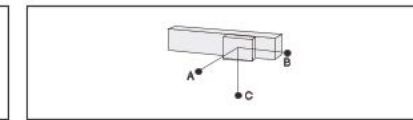
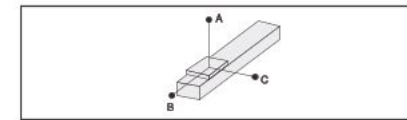

负载 Load	水平安装 Horizontal installation			侧面安装 Side mounting		
	A	B	C	A	B	C
5kg	1400	750	600	5kg	660	1100
8kg	1100	450	400	8kg	450	850
10kg	1000	350	350	10kg	350	800

传感器连接图<原点及端点> Sensor layout

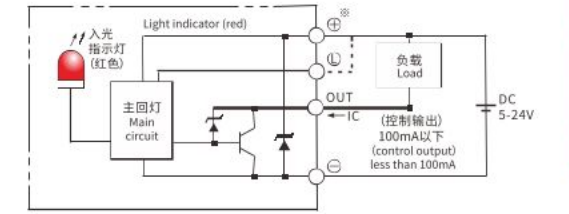

静态容许负载惯量 Static loading moment

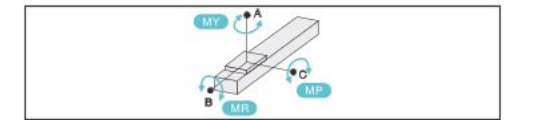

MY	MP	MR
110	110	120

*力矩表所表示的数据, 代表重心。
The torque value in the chart indicate the center of gravity.
*符合型录规范的正常试用下, 保证寿命为10000公里。
Operation life is 10,000km when the product is using under the specified conditions.
*侧吊使用无法套用标准规范, 如有需求请咨询我司业务。
The standard specification cannot be applied to the use of inverted crane. Please consult our business if necessary.

搭配伺服马达一览表 Suitable motor brand

品牌 Brand	马达记号 Mark	刹车有无 Brake	马达容量 Motor capacity	电源电压 AC-Voltage	伺服马达型号 Servo motor model	驱动器型号 Driver Model
三菱 Mitsubishi	M	无刹车(水平式样) No brake (horizontal type)	200	220	HG-KR73	MR-J4-70A
松下 Panasonic	P	无刹车(水平式样) No brake (horizontal type)	200	220	MHMD082G1U	MBDHT3520
台达 Delta	T	无刹车(水平式样) No brake (horizontal type)	200	220	ECMA-C20807ES	ASD-B20721-B



电机外置左侧/电机外置右侧
Motor external left side / Motor external right side

ML 电机外置左侧 Motor external left side

单位:Unit: mm

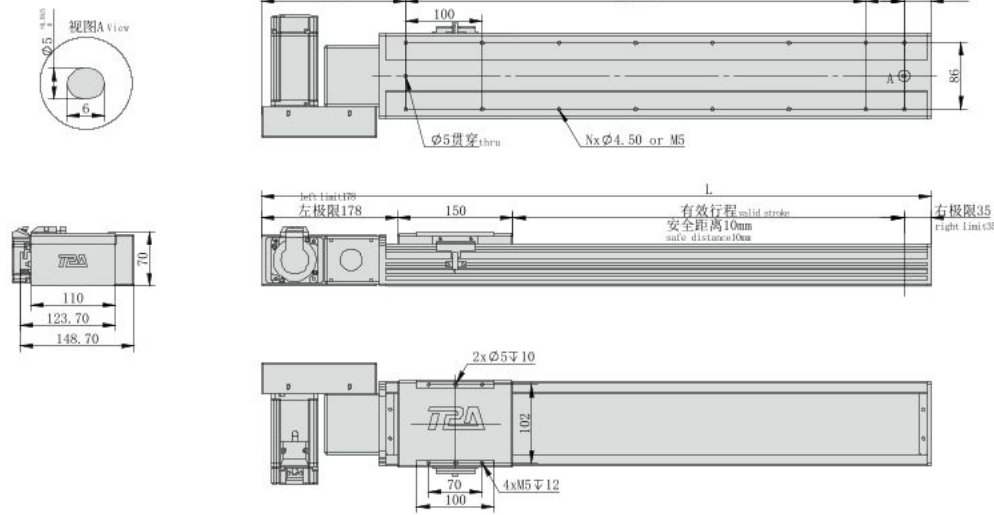

*不含电机重量。*Motor weight not included.

有效行程 Stroke	150	250	350	450	550	650	750	850	950	1050	1150	1250	1350	1450	1550	1650	1750	1850
L	523	623	723	823	923	1023	1123	1223	1323	1423	1523	1623	1723	1823	1923	2023	2123	2223
A	100	100	100	100	100	100	100	100	100	100	100	100	100	100	100	100	100	100
N	8	10	12	14	16	18	20	22	24	26	28	30	32	34	36	38	40	42
M	2	3	4	5	6	7	8	9	10	11	12	13	14	15	16	17	18	19
KG	4.8	5.3	5.8	6.3	6.8	7.3	7.8	8.3	8.8	9.3	9.8	10.3	10.8	11.3	11.8	12.3	12.8	13.3

如有超长行程及定制需求, 请咨询我司业务。If you have extra long trip and custom requirements, please consult our business.

电机外置左下/电机外置左上
Motor external lower left / Motor external upper left

LP 电机外置左下 Motor external lower left

单位:Unit: mm

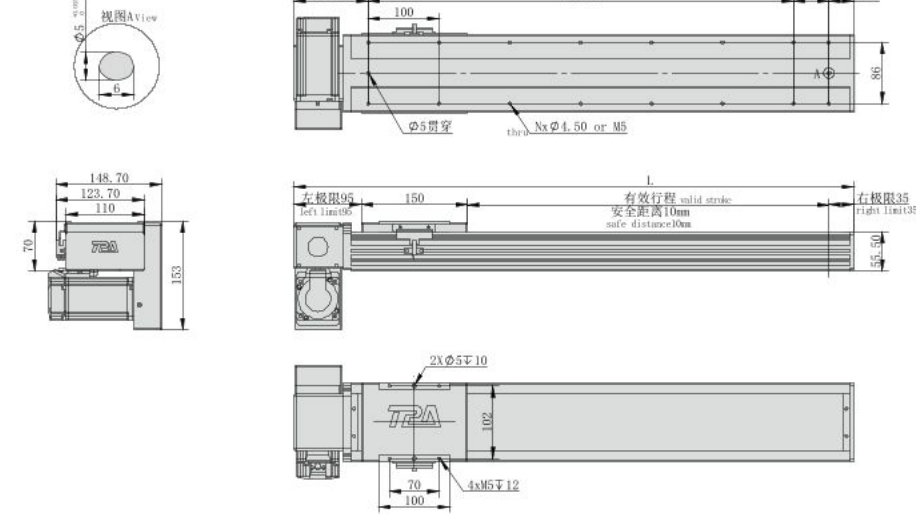

*不含电机重量。*Motor weight not included.

有效行程 Stroke	150	250	350	450	550	650	750	850	950	1050	1150	1250	1350	1450	1550	1650	1750	1850
L	440	540	640	740	840	940	1040	1140	1240	1340	1440	1540	1640	1740	1840	1940	2040	2140
A	100	100	100	100	100	100	100	100	100	100	100	100	100	100	100	100	100	100
N	8	10	12	14	16	18	20	22	24	26	28	30	32	34	36	38	40	42
M	2	3	4	5	6	7	8	9	10	11	12	13	14	15	16	17	18	19
KG	4.8	5.3	5.8	6.3	6.8	7.3	7.8	8.3	8.8	9.3	9.8	10.3	10.8	11.3	11.8	12.3	12.8	13.3

如有超长行程及定制需求, 请咨询我司业务。If you have extra long trip and custom requirements, please consult our business.

电机外置右侧 Motor external right side

MR 电机外置右侧 Motor external right side

单位:Unit: mm

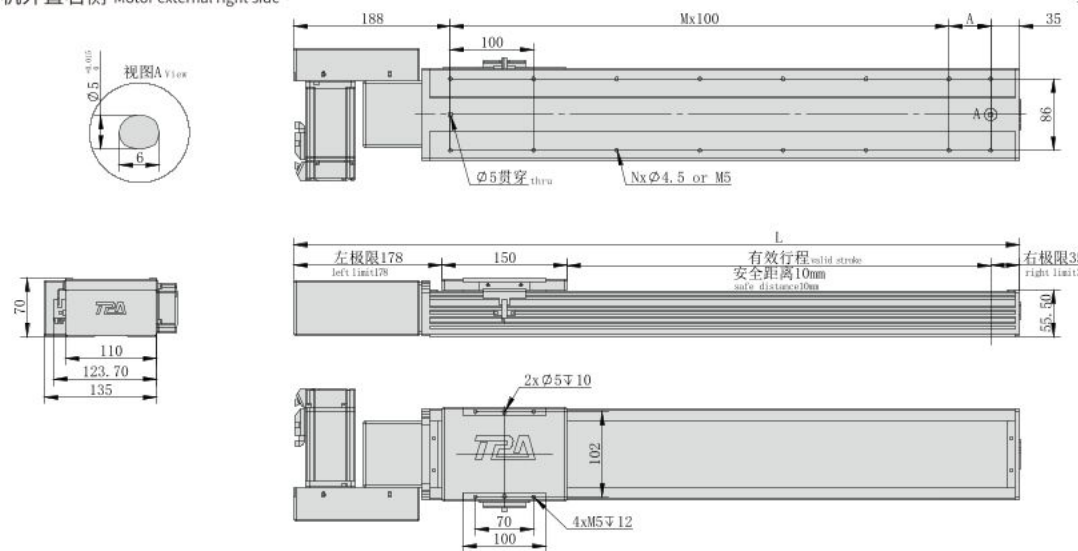

*不含电机重量。*Motor weight not included.

有效行程 Stroke	150	250	350	450	550	650	750	850	950	1050	1150	1250	1350	1450	1550	1650	1750	1850
L	523	623	723	823	923	1023	1123	1223	1323	1423	1523	1623	1723	1823	1923	2023	2123	2223
A	100	100	100	100	100	100	100	100	100	100	100	100	100	100	100	100	100	100
N	8	10	12	14	16	18	20	22	24	26	28	30	32	34	36	38	40	42
M	2	3	4	5	6	7	8	9	10	11	12	13	14	15	16	17	18	19
KG	4.8	5.3	5.8	6.3	6.8	7.3	7.8	8.3	8.8	9.3	9.8	10.3	10.8	11.3	11.8	12.3	12.8	13.3

如有超长行程及定制需求, 请咨询我司业务。If you have extra long trip and custom requirements, please consult our business.

电机外置左上 Motor external upper left

LU 电机外置左上 Motor external upper left

单位:Unit: mm

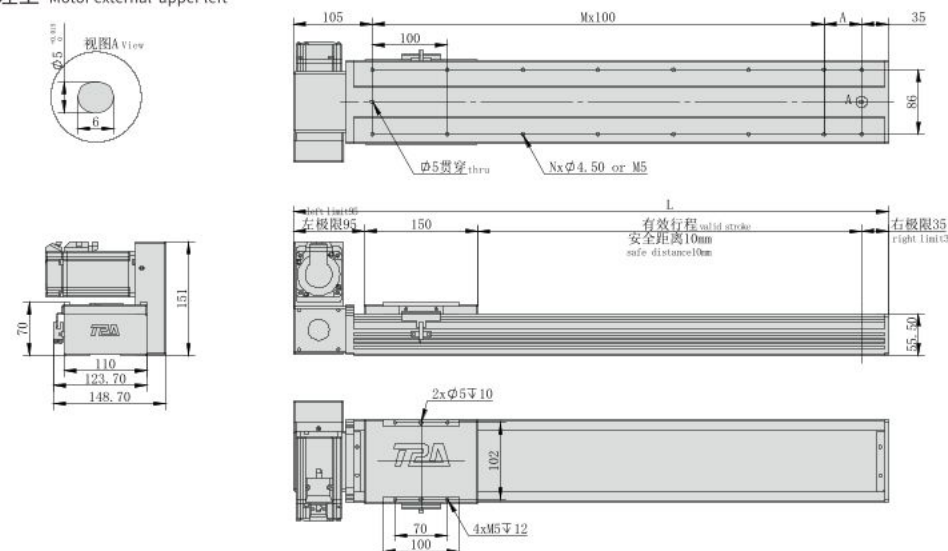

*不含电机重量。*Motor weight not included.

有效行程 Stroke	150	250	350	450	550	650	750	850	950	1050	1150	1250	1350	1450	1550	1650	1750	1850
L	440	540	640	740	840	940	1040	1140	1240	1340	1440	1540	1640	1740	1840	1940	2040	2140
A	100	100	100	100	100	100	100	100	100	100	100	100	100	100	100	100	100	100
N	8	10	12	14	16	18	20	22	24	26	28	30	32	34	36	38	40	42
M	2	3	4	5	6	7	8	9	10	11	12	13	14	15	16	17	18	19
KG	4.8	5.3	5.8	6.3	6.8	7.3	7.8	8.3	8.8	9.3	9.8	10.3	10.8	11.3	11.8	12.3	12.8	13.3

如有超长行程及定制需求, 请咨询我司业务。If you have extra long trip and custom requirements, please consult our business.

- HNR
- HCR
- HNB
- HC B
- HNT
- XYZ
- ONB
- OCB
- GCR
- GCB
- GCBS
- GCRS
- ESR
- EMR
- EHR
- KSR
- LNP
- DDR

参考资料
Reference data



电机外置右下/电机外置右上
Motor external lower right / Motor external upper right

RP 电机外置右下 Motor external lower right

单位:Unit: mm

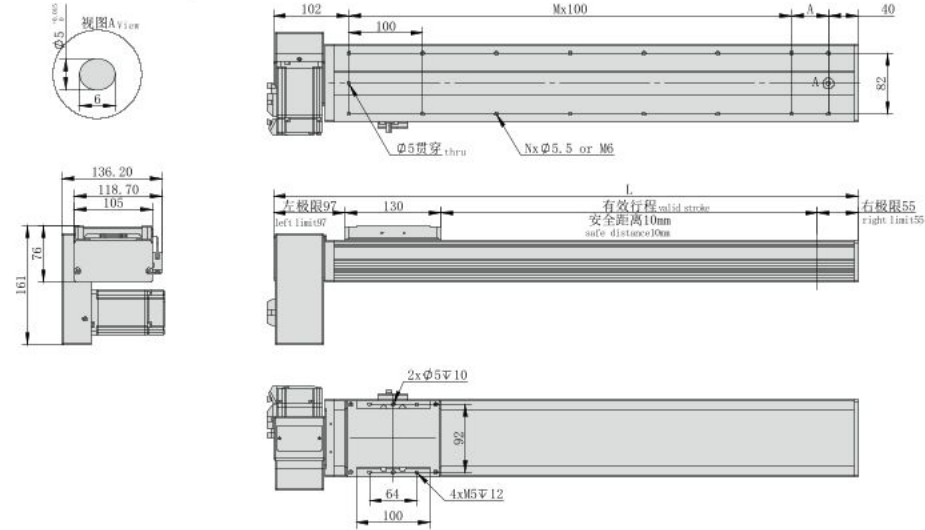

*不含电机重量。*Motor weight not included.

有效行程 Stroke	150	250	350	450	550	650	750	850	950	1050	1150	1250	1350	1450	1550	1650	1750	1850
L	440	540	640	740	840	940	1040	1140	1240	1340	1440	1540	1640	1740	1840	1940	2040	2140
A	100	100	100	100	100	100	100	100	100	100	100	100	100	100	100	100	100	100
N	8	10	12	14	16	18	20	22	24	26	28	30	32	34	36	38	40	42
M	2	3	4	5	6	7	8	9	10	11	12	13	14	15	16	17	18	19
KG	4.8	5.3	5.8	6.3	6.8	7.3	7.8	8.3	8.8	9.3	9.8	10.3	10.8	11.3	11.8	12.3	12.8	13.3

如有超长行程及定制需求, 请咨询我司业务。If you have extra long trip and custom requirements, please consult our business.

RU 电机外置右上 Motor external upper right

单位:Unit: mm

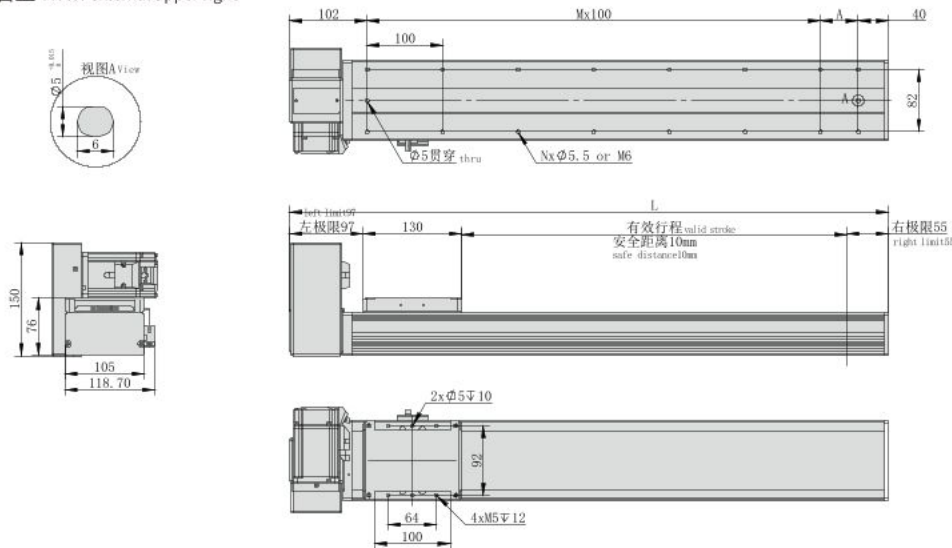

*不含电机重量。*Motor weight not included.

有效行程 Stroke	150	250	350	450	550	650	750	850	950	1050	1150	1250	1350	1450	1550	1650	1750	1850
L	440	540	640	740	840	940	1040	1140	1240	1340	1440	1540	1640	1740	1840	1940	2040	2140
A	100	100	100	100	100	100	100	100	100	100	100	100	100	100	100	100	100	100
N	8	10	12	14	16	18	20	22	24	26	28	30	32	34	36	38	40	42
M	2	3	4	5	6	7	8	9	10	11	12	13	14	15	16	17	18	19
KG	4.8	5.3	5.8	6.3	6.8	7.3	7.8	8.3	8.8	9.3	9.8	10.3	10.8	11.3	11.8	12.3	12.8	13.3

如有超长行程及定制需求, 请咨询我司业务。If you have extra long trip and custom requirements, please consult our business.

MEMO

- HNR
- HCR
- HNB
- HCB
- HNT
- XYZ
- ONB
- OCB
- GCR
- GCB
- GCBS
- GCRS
- ESR
- EMR
- EHR
- KSR
- LNP
- DDR
- 参考资料
Reference data



此图仅供参考, 出货规格详见尺寸图面
This picture for reference only, specs details according with the drawing.

最大行程 Max stroke 3050mm

最高速度 Max speed 5500mm/s

马达容量 Motor output 200W

直线滑轨 Linear guide 15X12.5-2支

型号表达方式 Ordering method

TPA-HCB-120D-110-L3050-MR-Y-P20-N3-F

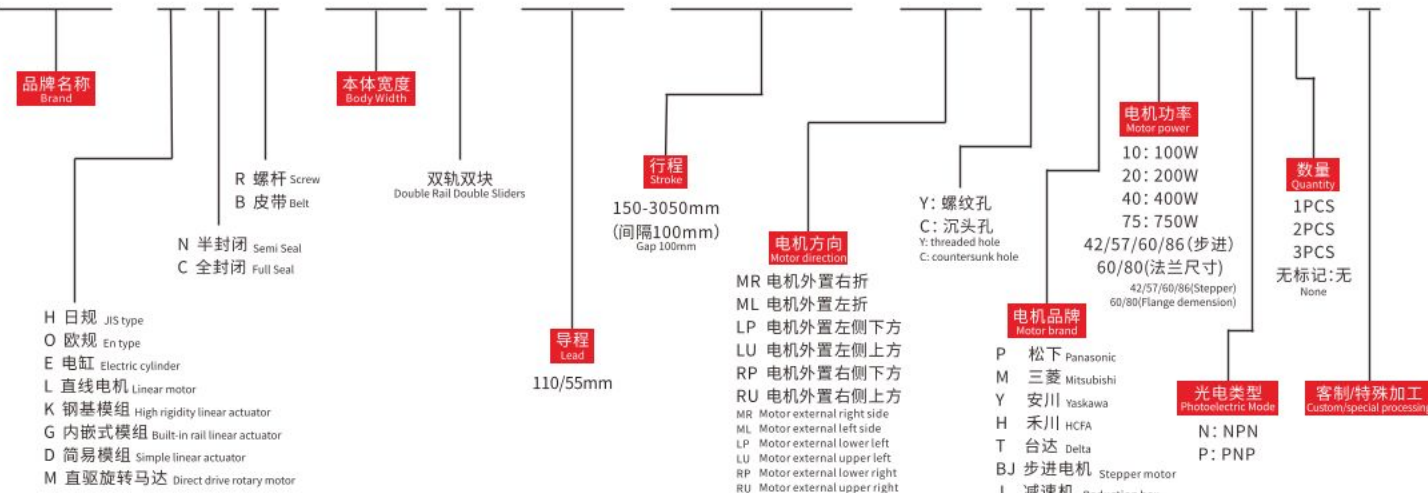

产品性能参数如下 Product performance parameters are as follows

规格 Spec	电机功率 (W) Motor power (W)	200	
	重复定位精度 (mm) Repeated positioning accuracy (mm)	±0.04	
	减速比 (mm) Reduction ratio	1:1	1:2
	导程 (mm) Lead (mm)	110	55
	最高速度 (mm/s) Maximum speed (mm/s)	5500	
	电机额定转速 (RPM) Rated speed of motor (RPM)	3000	
部 品 Parts	最大可搬重量 Maximum Payload	14	28
	标准行程 (mm) Stroke pitch (mm)	150~3050mm/100 间隔100 mm Pitch	
	基座材质 Material of base	硬质挤压铝材A1 Hard extruded aluminum A1	
使用环境 Operating environment	0~40°C, 85%RH(无凝结) No condensation		

注1: 使用非上述功率电机时请依据实际参数推算。
Note 1: When using a motor with a power other than the above, please calculate according to the actual parameters.
注2: 最高速度因行程和负载而异, 当螺杆细长比大于1:50时, 可能会因螺杆临界速度产生共振和抖动, 应适当下调运行速度, 一般螺杆每增长100mm, 速度应下调10~15%。
Note 2: The maximum speed varies with stroke and load. When the screw slenderness ratio is greater than 1:50, resonance and jitter may occur due to the critical speed of the screw, so the running speed should be reduced appropriately. Generally, the speed should be reduced by 10~15% for every 100mm increase of the screw.

传感器连接图<原点及端点> Sensor layout

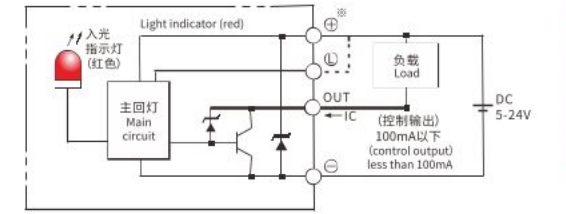

容许负载力矩表 N.m Allowable overhang

负载 Load	水平安装 Horizontal installation (单位Unit:mm)			侧面安装 Side mounting (单位Unit:mm)		
	A	B	C	A	B	C
5kg	1794	688	538	348	446	1170
10kg	858	324	253	285	365	961
20kg	670	251	197	197	251	670

静态容许负载惯量 Static loading moment

惯量 Inertia	惯量值 Inertia value (单位Unit:N.m)
MY	150
MP	150
MR	130

*力矩表所表示的数据, 代表重心。
The torque value in the chart indicate the center of gravity.
*符合型录规范的正常试用下, 保证寿命为10000公里。
Operation life is 10,000km when the product is using under the specified conditions.
*侧吊使用无法套用标准规范, 如有需求请咨询我司业务。
The standard specification cannot be applied to the use of inverted crane. Please consult our business if necessary.

搭配伺服马达一览表 Suitable motor brand

品牌 Brand	马达记号 Mark	刹车有无 Brake	马达容量 Motor capacity	电源电压 AC-Voltage	伺服马达型号 Servo motor model	驱动器型号 Driver Model
三菱 Mitsubishi	M	无刹车(水平式样) No brake (horizontal type)	200	220	HG-KR73	MR-J4-70A
松下 Panasonic	P	无刹车(水平式样) No brake (horizontal type)	200	220	MHMD082G1U	MBDHT3520
台达 Delta	T	无刹车(水平式样) No brake (horizontal type)	200	220	ECMA-C20807ES	ASD-B20721-B



电机外置左侧/电机外置右侧
Motor external left side / Motor external right side

ML 电机外置左侧 Motor external left side

单位:Unit: mm

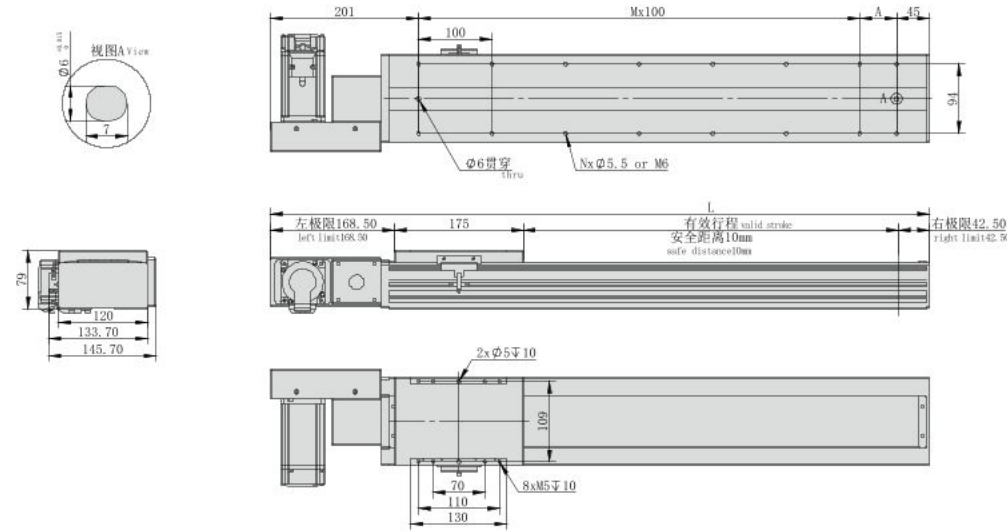

*不含电机重量。*Motor weight not included.

有效行程 Stroke	150	250	350	450	550	650	750	850	950	1050	1150	1250	1350	1450	1550	1650	1750	1850	1950	2050	2150	2250	2350	2450	2550	2650	2750	2850	2950	3050
L	546	646	746	846	946	1046	1146	1246	1346	1446	1546	1646	1746	1846	1946	2046	2146	2246	2346	2446	2546	2646	2746	2846	2946	3046	3146	3246	3346	3446
A	100	100	100	100	100	100	100	100	100	100	100	100	100	100	100	100	100	100	100	100	100	100	100	100	100	100	100	100	100	100
N	8	10	12	14	16	18	20	22	24	26	28	30	32	34	36	38	40	42	44	46	48	50	52	54	56	58	60	62	64	66
M	2	3	4	5	6	7	8	9	10	11	12	13	14	15	16	17	18	19	20	21	22	23	24	25	26	27	28	29	30	31
KG	7	8	9	10	11	12	13	14	15	16	17	18	19	20	21	22	23	24	25	26	27	28	29	30	31	32	33	34	35	36

如有超长行程及定制需求, 请咨询我司业务。 If you have extra long trip and custom requirements, please consult our business.

电机外置左下/电机外置左上
Motor external lower left / Motor external upper left

LP 电机外置左下 Motor external lower left

单位:Unit: mm

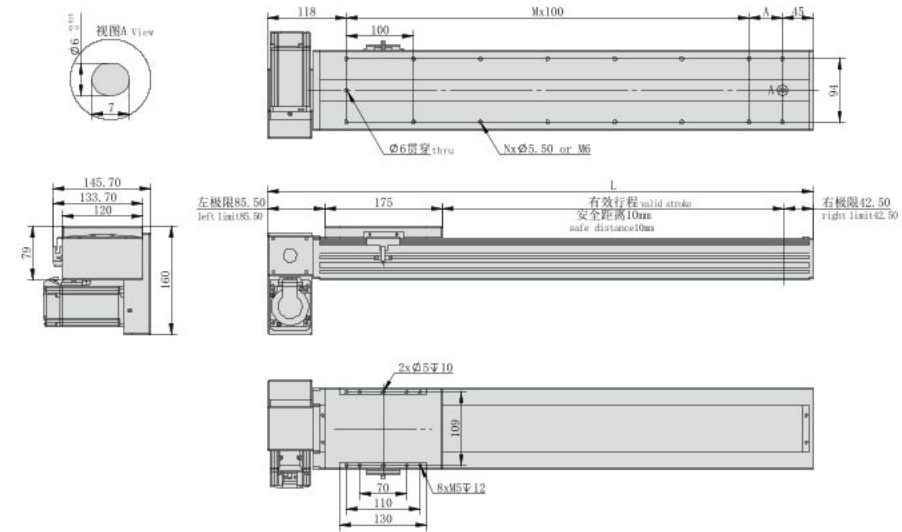

*不含电机重量。*Motor weight not included.

有效行程 Stroke	150	250	350	450	550	650	750	850	950	1050	1150	1250	1350	1450	1550	1650	1750	1850	1950	2050	2150	2250	2350	2450	2550	2650	2750	2850	2950	3050
L	463	563	663	763	863	963	1063	1163	1263	1363	1463	1563	1663	1763	1863	1963	2063	2163	2263	2363	2463	2563	2663	2763	2863	2963	3063	3163	3263	3363
A	100	100	100	100	100	100	100	100	100	100	100	100	100	100	100	100	100	100	100	100	100	100	100	100	100	100	100	100	100	100
N	8	10	12	14	16	18	20	22	24	26	28	30	32	34	36	38	40	42	44	46	48	50	52	54	56	58	60	62	64	66
M	2	3	4	5	6	7	8	9	10	11	12	13	14	15	16	17	18	19	20	21	22	23	24	25	26	27	28	29	30	31
KG	7	8	9	10	11	12	13	14	15	16	17	18	19	20	21	22	23	24	25	26	27	28	29	30	31	32	33	34	35	36

如有超长行程及定制需求, 请咨询我司业务。 If you have extra long trip and custom requirements, please consult our business.

MR 电机外置右侧 Motor external right side

单位:Unit: mm

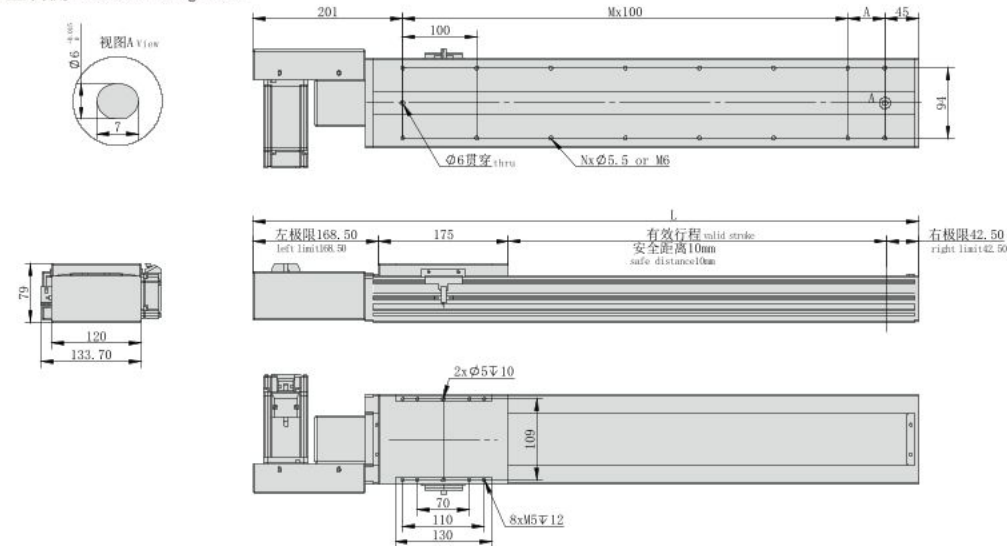

*不含电机重量。*Motor weight not included.

有效行程 Stroke	150	250	350	450	550	650	750	850	950	1050	1150	1250	1350	1450	1550	1650	1750	1850	1950	2050	2150	2250	2350	2450	2550	2650	2750	2850	2950	3050
L	546	646	746	846	946	1046	1146	1246	1346	1446	1546	1646	1746	1846	1946	2046	2146	2246	2346	2446	2546	2646	2746	2846	2946	3046	3146	3246	3346	3446
A	100	100	100	100	100	100	100	100	100	100	100	100	100	100	100	100	100	100	100	100	100	100	100	100	100	100	100	100	100	100
N	8	10	12	14	16	18	20	22	24	26	28	30	32	34	36	38	40	42	44	46	48	50	52	54	56	58	60	62	64	66
M	2	3	4	5	6	7	8	9	10	11	12	13	14	15	16	17	18	19	20	21	22	23	24	25	26	27	28	29	30	31
KG	7	8	9	10	11	12	13	14	15	16	17	18	19	20	21	22	23	24	25	26	27	28	29	30	31	32	33	34	35	36

如有超长行程及定制需求, 请咨询我司业务。 If you have extra long trip and custom requirements, please consult our business.

LU 电机外置左上 Motor external upper left

单位:Unit: mm

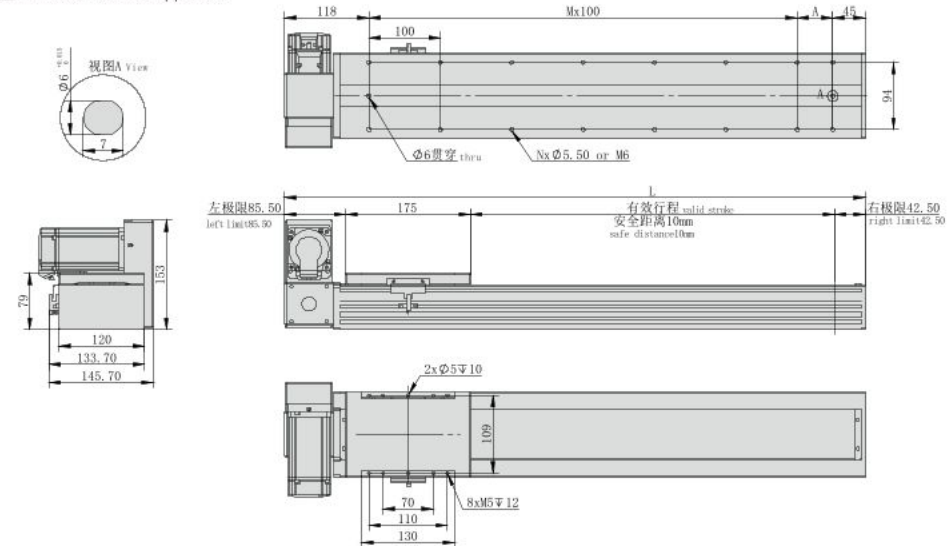

*不含电机重量。*Motor weight not included.

有效行程 Stroke	150	250	350	450	550	650	750	850	950	1050	1150	1250	1350	1450	1550	1650	1750	1850	1950	2050	2150	2250	2350	2450	2550	2650	2750	2850	2950	3050
L	463	563	663	763	863	963	1063	1163	1263	1363	1463	1563	1663	1763	1863	1963	2063	2163	2263	2363	2463	2563	2663	2763	2863	2963	3063	3163	3263	3363
A	100	100	100	100	100	100	100	100	100	100	100	100	100	100	100	100	100	100	100	100	100	100	100	100	100	100	100	100	100	100
N	8	10	12	14	16	18	20	22	24	26	28	30	32	34	36	38	40	42	44	46	48	50	52	54	56	58	60	62	64	66
M	2	3	4	5	6	7	8	9	10	11	12	13	14	15	16	17	18	19	20	21	22	23	24	25	26	27	28	29	30	31
KG	7	8	9	10	11	12	13	14	15	16	17	18	19	20	21	22	23	24	25	26	27	28	29	30	31	32	33	34	35	36

如有超长行程及定制需求, 请咨询我司业务。 If you have extra long trip and custom requirements, please consult our business.

- HNR
- HCR
- HNB
- HC B
- HNT
- XYZ
- ONB
- OCB
- GCR
- GCB
- GCBS
- GCRS
- ESR
- EMR
- EHR
- KSR
- LNP
- DDR

参考资料
Reference
data



电机外置右下/电机外置右上
Motor external lower right / Motor external upper right

RP 电机外置右下 Motor external lower right

单位:Unit: mm

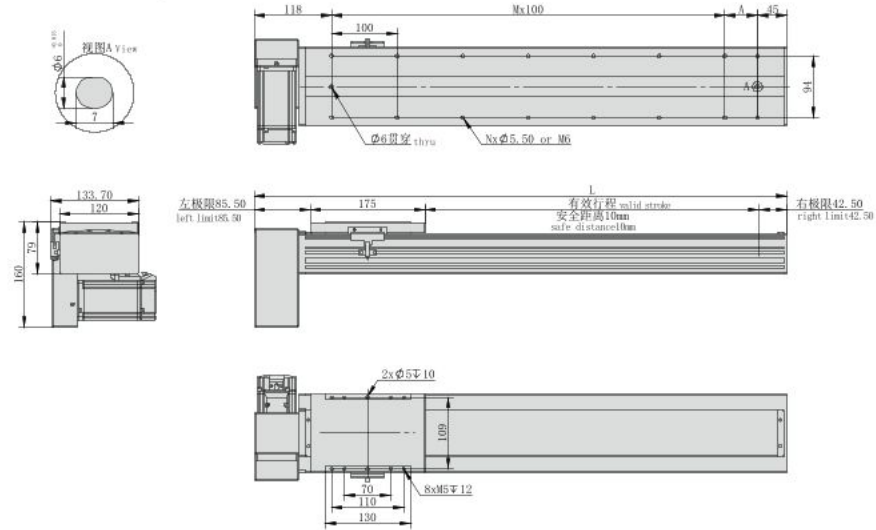

*不含电机重量。*Motor weight not included.

有效行程 Stroke	150	250	350	450	550	650	750	850	950	1050	1150	1250	1350	1450	1550	1650	1750	1850	1950	2050	2150	2250	2350	2450	2550	2650	2750	2850	2950	3050
L	463	563	663	763	863	963	1063	1163	1263	1363	1463	1563	1663	1763	1863	1963	2063	2163	2263	2363	2463	2563	2663	2763	2863	2963	3063	3163	3263	3363
A	100	100	100	100	100	100	100	100	100	100	100	100	100	100	100	100	100	100	100	100	100	100	100	100	100	100	100	100	100	100
N	8	10	12	14	16	18	20	22	24	26	28	30	32	34	36	38	40	42	44	46	48	50	52	54	56	58	60	62	64	66
M	2	3	4	5	6	7	8	9	10	11	12	13	14	15	16	17	18	19	20	21	22	23	24	25	26	27	28	29	30	31
KG	7	8	9	10	11	12	13	14	15	16	17	18	19	20	21	22	23	24	25	26	27	28	29	30	31	32	33	34	35	36

如有超长行程及定制需求, 请咨询我司业务。 If you have extra long trip and custom requirements, please consult our business.

RU 电机外置右上 Motor external upper right

单位:Unit: mm

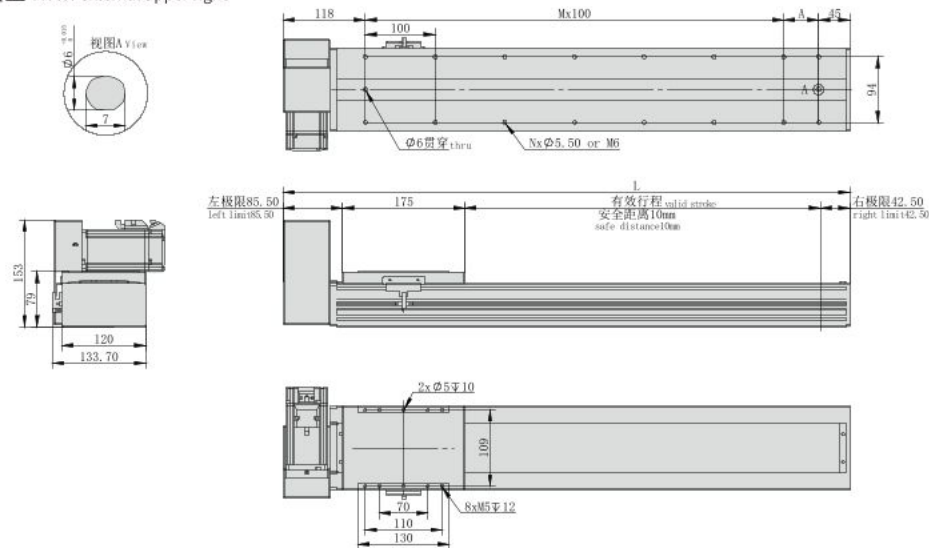

*不含电机重量。*Motor weight not included.

有效行程 Stroke	150	250	350	450	550	650	750	850	950	1050	1150	1250	1350	1450	1550	1650	1750	1850	1950	2050	2150	2250	2350	2450	2550	2650	2750	2850	2950	3050
L	463	563	663	763	863	963	1063	1163	1263	1363	1463	1563	1663	1763	1863	1963	2063	2163	2263	2363	2463	2563	2663	2763	2863	2963	3063	3163	3263	3363
A	100	100	100	100	100	100	100	100	100	100	100	100	100	100	100	100	100	100	100	100	100	100	100	100	100	100	100	100	100	100
N	8	10	12	14	16	18	20	22	24	26	28	30	32	34	36	38	40	42	44	46	48	50	52	54	56	58	60	62	64	66
M	2	3	4	5	6	7	8	9	10	11	12	13	14	15	16	17	18	19	20	21	22	23	24	25	26	27	28	29	30	31
KG	7	8	9	10	11	12	13	14	15	16	17	18	19	20	21	22	23	24	25	26	27	28	29	30	31	32	33	34	35	36

如有超长行程及定制需求, 请咨询我司业务。 If you have extra long trip and custom requirements, please consult our business.

MEMO

- HNR
- HCR
- HNB
- HC B
- HNT
- XYZ
- ONB
- OCB
- GCR
- GCB
- GCBS
- GCRS
- ESR
- EMR
- EHR
- KSR
- LNP
- DDR
- 参考资料
Reference data



重复精度
Repeat Accuracy
±0.04
mm

此图仅供参考, 出货规格详见尺寸图面
This picture for reference only, specs details according with the drawing.

最大行程
Max stroke 3050mm

最高速度
Max speed 6000mm/s

马达容量
Motor output 400W

直线滑轨
Linear guide 15X12.5-2支

型号表达方式 Ordering method

TPA-HCB-140D-120-L3050-MR-Y-P40-N3-F

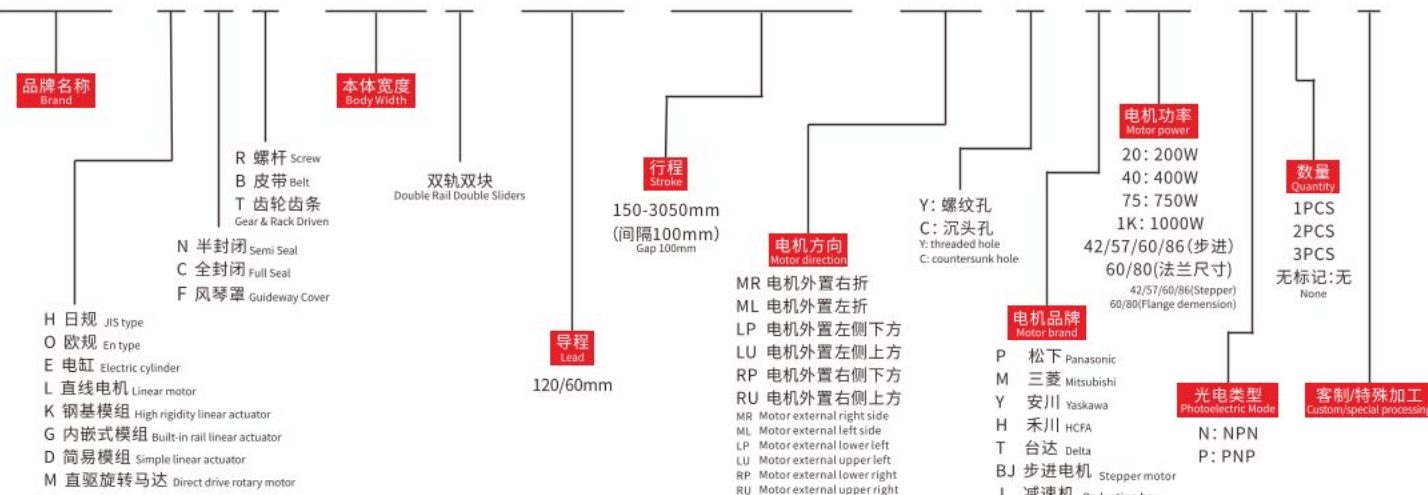

产品性能参数如下 Product performance parameters are as follows

规格 Spec	电机功率 (W) Motor power (W)	400	
	重复定位精度 (mm) Repeated positioning accuracy (mm)	±0.04	
	减速比 (mm) Reduction ratio	1:1	1:2
	导程 (mm) Lead (mm)	120	60
	最高速度 (mm/s) Maximum speed (mm/s)	6000	
	电机额定转速 (RPM) Rated speed of motor (RPM)	3000	
部 品 Parts	最大可搬重量 Maximum Payload	18	36
	标准行程 (mm) Stroke pitch (mm)	150~3050mm/100 间隔100 mm Pitch	
部 品 Parts	基座材质 Material of base	硬质挤压铝材A1 Hard extruded aluminum A1	
	使用环境 Operating environment	0~40°C, 85%RH(无凝结) No condensation	

注1: 使用非上述功率电机时请依据实际参数推算。
Note 1: When using a motor with a power other than the above, please calculate according to the actual parameters.

注2: 最高速度因行程和负载而异, 当螺杆菌细长比大于1:50时, 可能会因螺杆菌临界速度产生共振和抖动, 应适当下调运行速度, 一般螺杆菌每增长100mm, 速度应下调10~15%。
Note 2: The maximum speed varies with stroke and load. When the screw slenderness ratio is greater than 1:50, resonance and jitter may occur due to the critical speed of the screw, so the running speed should be reduced appropriately. Generally, the speed should be reduced by 10~15% for every 100mm increase of the screw.

传感器连接图<原点及端点> Sensor layout

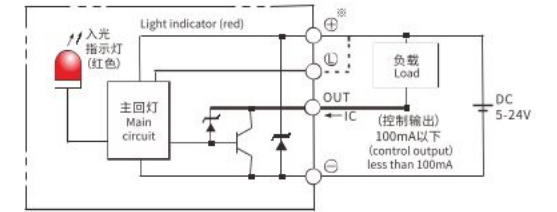

容许负载力矩表 N.m Allowable overhang

		(单位Unit:mm)			(单位Unit:mm)			
		水平安装 Horizontal installation			侧面安装 Side mounting			
		A	B	C	A	B	C	
负载 Load	5kg	2629	1279	1150	5kg	1365	1219	2339
	10kg	1559	719	712	10kg	699	649	1319
	20kg	1209	475	434	20kg	379	385	935
	32kg	766	310	288	32kg	199	220	600

静态容许负载惯量 Static loading moment

		(单位Unit:N.m)
MY		551
MP		552
MR		485

*力矩表所表示的数据, 代表重心。
The torque value in the chart indicate the center of gravity.

*符合型录规范的正常试用下, 保证寿命为10000公里。
Operation life is 10,000km when the product is using under the specified conditions.

*侧吊使用无法套用标准规范, 如有需求请咨询我司业务。
The standard specification cannot be applied to the use of inverted crane. Please consult our business if necessary.

搭配伺服马达一览表 Suitable motor brand

品牌 Brand	马达记号 Mark	刹车有无 Brake	马达容量 Motor capacity	电源电压 AC-Voltage	伺服马达型号 Servo motor model	驱动器型号 Driver Model
三菱 Mitsubishi	M	无刹车(水平式样) No brake (horizontal type)	200	220	HG-KR73	MR-J4-70A
松下 Panasonic	P	无刹车(水平式样) No brake (horizontal type)	200	220	MHMD082G1U	MBDHT3520
台达 Delta	T	无刹车(水平式样) No brake (horizontal type)	200	220	ECMA-C20807ES	ASD-B20721-B

电机外置左侧/电机外置右侧
Motor external left side / Motor external right side

ML 电机外置左侧 Motor external left side

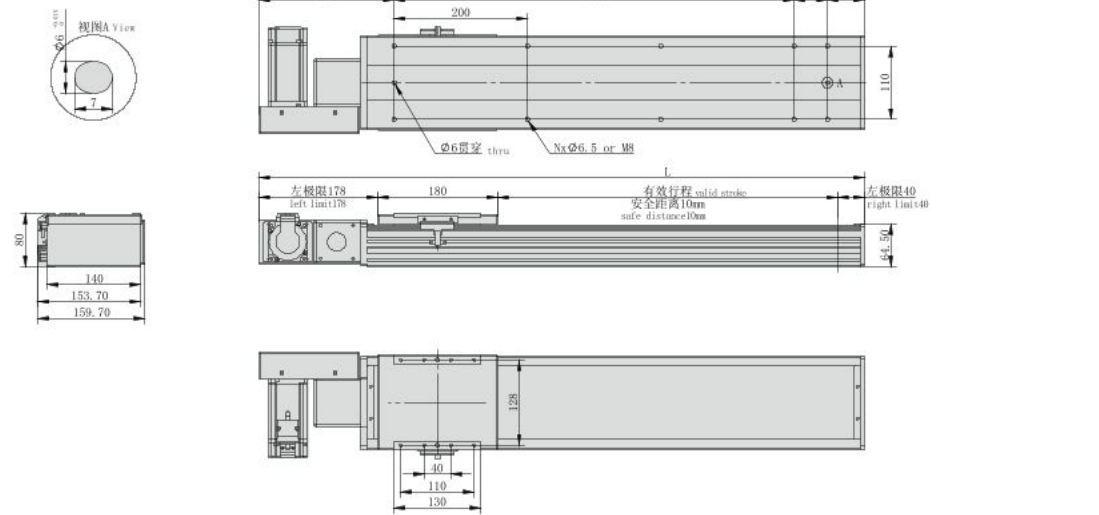

单位:Unit: mm

*不含电机重量。*Motor weight not included.

有效行程 Stroke	150	250	350	450	550	650	750	850	950	1050	1150	1250	1350	1450	1550	1650	1750	1850	1950	2050	2150	2250	2350	2450	2550	2650	2750	2850	2950	3050
L	558	658	758	858	958	1058	1158	1258	1358	1458	1558	1658	1758	1858	1958	2058	2158	2258	2358	2458	2558	2658	2758	2858	2958	3058	3158	3258	3358	3458
A	100	200	100	200	100	200	100	200	100	200	100	200	100	200	100	200	100	200	100	200	100	200	100	200	100	200	100	200	100	200
N	6	6	8	8	10	10	12	12	14	14	16	16	18	18	20	20	22	22	24	24	26	26	28	28	30	30	32	32	34	34
M	1	1	2	2	3	3	4	4	5	5	6	6	7	7	8	8	9	9	10	10	11	11	12	12	13	13	14	14	15	15
KG	8.5	9	9.5	10	10.5	11	11.5	12	12.5	13	13.5	14	14.5	15	15.5	16	16.5	17	17.5	18	18.5	19	19.5	20	20.5	21	21.5	22	22.5	23

如有超长行程及定制需求, 请咨询我司业务。If you have extra long trip and custom requirements, please consult our business.

电机外置左下/电机外置左上
Motor external lower left / Motor external upper left

LP 电机外置左下 Motor external lower left

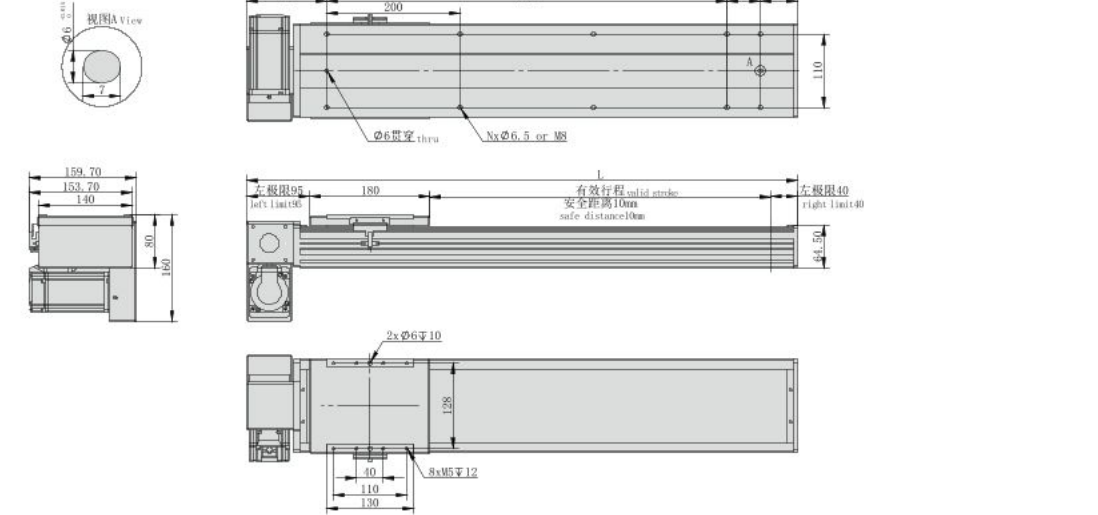

单位:Unit: mm

*不含电机重量。*Motor weight not included.

有效行程 Stroke	150	250	350	450	550	650	750	850	950	1050	1150	1250	1350	1450	1550	1650	1750	1850	1950	2050	2150	2250	2350	2450	2550	2650	2750	2850	2950	3050
L	475	575	675	775	875	975	1075	1175	1275	1375	1475	1575	1675	1775	1875	1975	2075	2175	2275	2375	2475	2575	2675	2775	2875	2975	3075	3175	3275	3375
A	100	200	100	200	100	200	100	200	100	200	100	200	100	200	100	200	100	200	100	200	100	200	100	200	100	200	100	200	100	200
N	6	6	8	8	10	10	12	12	14	14	16	16	18	18	20	20	22	22	24	24	26	26	28	28	30	30	32	32	34	34
M	1	1	2	2	3	3	4	4	5	5	6	6	7	7	8	8	9	9	10	10	11	11	12	12	13	13	14	14	15	15
KG	8.5	9	9.5	10	10.5	11	11.5	12	12.5	13	13.5	14	14.5	15	15.5	16	16.5	17	17.5	18	18.5	19	19.5	20	20.5	21	21.5	22	22.5	23

如有超长行程及定制需求, 请咨询我司业务。If you have extra long trip and custom requirements, please consult our business.

MR 电机外置右侧 Motor external right side

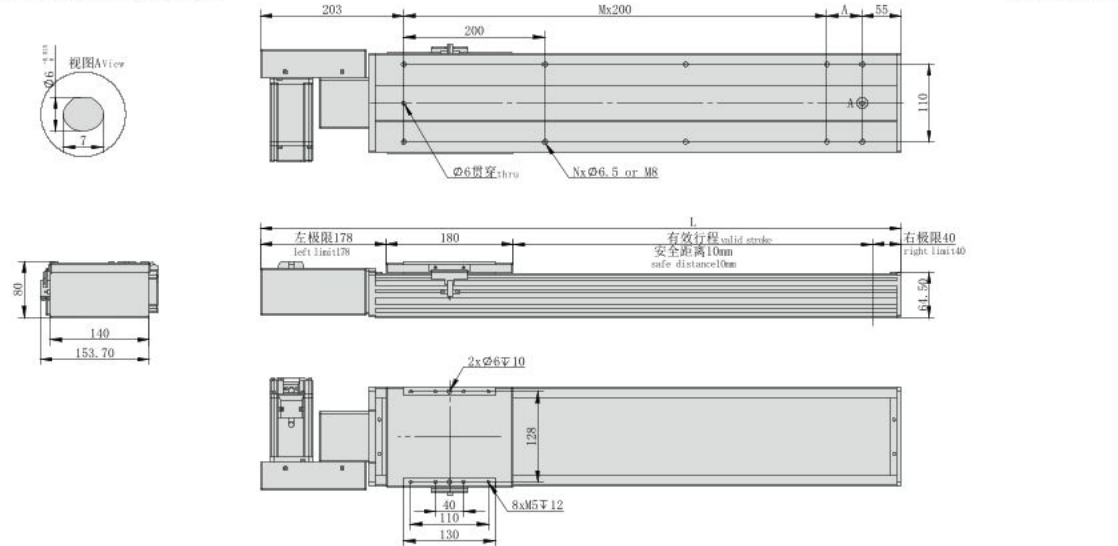

单位:Unit: mm

*不含电机重量。*Motor weight not included.

有效行程 Stroke	150	250	350	450	550	650	750	850	950	1050	1150	1250	1350	1450	1550	1650	1750	1850	1950	2050	2150	2250	2350	2450	2550	2650	2750	2850	2950	3050
L	558	658	758	858	958	1058	1158	1258	1358	1458	1558	1658	1758	1858	1958	2058	2158	2258	2358	2458	2558	2658	2758	2858	2958	3058	3158	3258	3358	3458
A	100	200	100	200	100	200	100	200	100	200	100	200	100	200	100	200	100	200	100	200	100	200	100	200	100	200	100	200	100	200
N	6	6	8	8	10	10	12	12	14	14	16	16	18	18	20	20	22	22	24	24	26	26	28	28	30	30	32	32	34	34
M	1	1	2	2	3	3	4	4	5	5	6	6	7	7	8	8	9	9	10	10	11	11	12	12	13	13	14	14	15	15
KG	8.5	9	9.5	10	10.5	11	11.5	12	12.5	13	13.5	14	14.5	15	15.5	16	16.5	17	17.5	18	18.5	19	19.5	20	20.5	21	21.5	22	22.5	23

如有超长行程及定制需求, 请咨询我司业务。If you have extra long trip and custom requirements, please consult our business.

LU 电机外置左上 Motor external upper left

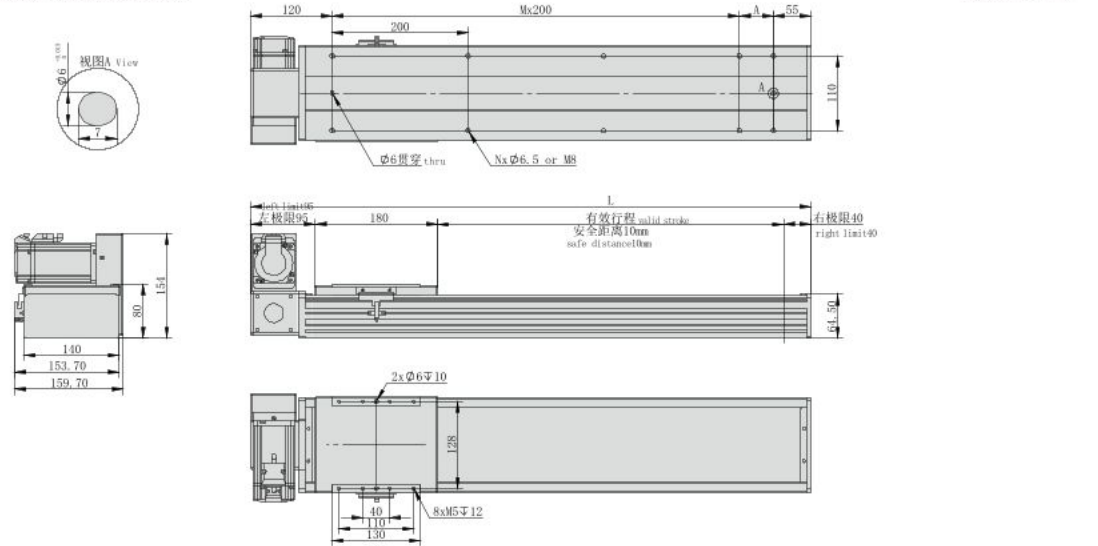

单位:Unit: mm

*不含电机重量。*Motor weight not included.

有效行程 Stroke	150	250	350	450	550	650	750	850	950	1050	1150	1250	1350	1450	1550	1650	1750	1850	1950	2050	2150	2250	2350	2450	2550	2650	2750	2850	2950	3050
L	475	575	675	775	875	975	1075	1175	1275	1375	1475	1575	1675	1775	1875	1975	2075	2175	2275	2375	2475	2575	2675	2775	2875	2975	3075	3175	3275	3375
A	100	200	100	200	100	200	100	200	100	200	100	200	100	200	100	200	100	200	100	200	100	200	100	200	100	200	100	200	100	200
N	6	6	8	8	10	10	12	12	14	14	16	16	18	18	20	20	22	22	24	24	26	26	28	28	30	30	32	32	34	34
M	1	1	2	2	3	3	4	4	5	5	6	6	7	7	8	8	9	9	10	10	11	11	12	12	13	13	14	14	15	15
KG	8.5	9	9.5	10	10.5	11	11.5	12	12.5	13	13.5	14	14.5	15	15.5	16	16.5	17	17.5	18	18.5	19	19.5	20	20.5	21	21.5	22	22.5	23

如有超长行程及定制需求, 请咨询我司业务。If you have extra long trip and custom requirements, please consult our business.

- HNR
- HCR
- HNB
- HC B
- HNT
- XYZ
- ONB
- OCB
- GCR
- GCB
- GCBS
- GCRS
- ESR
- EMR
- EHR
- KSR
- LNP
- DDR

参考资料
Reference
data



电机外置右下/电机外置右上
Motor external lower right / Motor external upper right

RP 电机外置右下 Motor external lower right

单位:Unit: mm

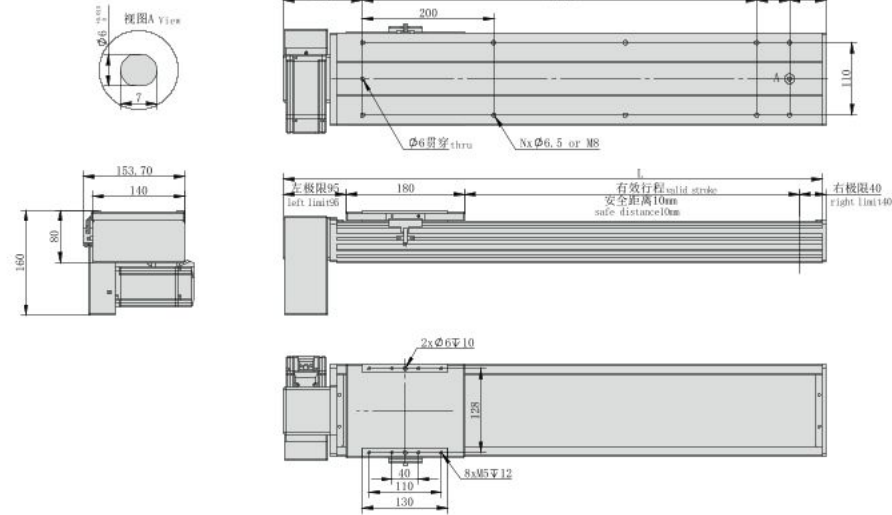

*不含电机重量。*Motor weight not included.

有效行程 Stroke	150	250	350	450	550	650	750	850	950	1050	1150	1250	1350	1450	1550	1650	1750	1850	1950	2050	2150	2250	2350	2450	2550	2650	2750	2850	2950	3050
L	475	575	675	775	875	975	1075	1175	1275	1375	1475	1575	1675	1775	1875	1975	2075	2175	2275	2375	2475	2575	2675	2775	2875	2975	3075	3175	3275	3375
A	100	200	100	200	100	200	100	200	100	200	100	200	100	200	100	200	100	200	100	200	100	200	100	200	100	200	100	200	100	200
N	6	6	8	8	10	10	12	12	14	14	16	16	18	18	20	20	22	22	24	24	26	26	28	28	30	30	32	32	34	34
M	1	1	2	2	3	3	4	4	5	5	6	6	7	7	8	8	9	9	10	10	11	11	12	12	13	13	14	14	15	15
KG	8.5	9	9.5	10	10.5	11	11.5	12	12.5	13	13.5	14	14.5	15	15.5	16	16.5	17	17.5	18	18.5	19	19.5	20	20.5	21	21.5	22	22.5	23

如有超长行程及定制需求, 请咨询我司业务。 If you have extra long trip and custom requirements, please consult our business.

RU 电机外置右上 Motor external upper right

单位:Unit: mm

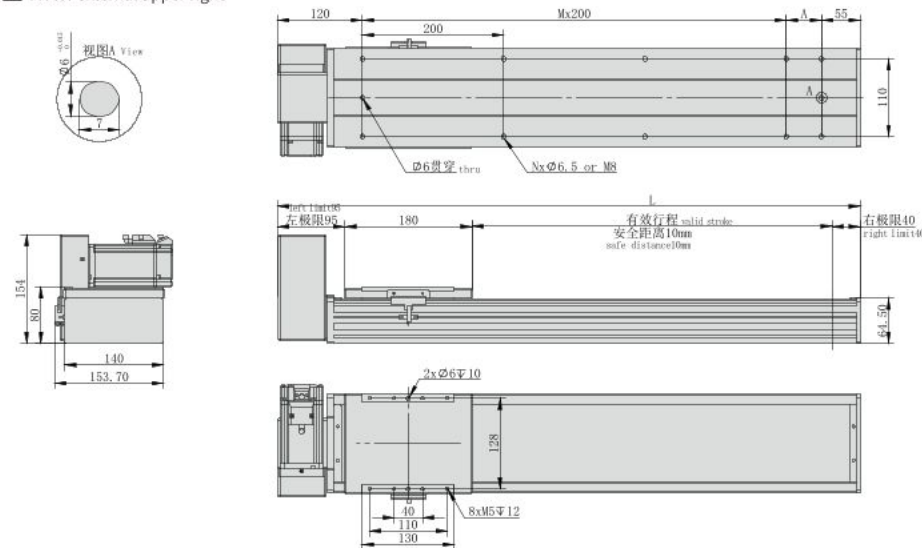

*不含电机重量。*Motor weight not included.

有效行程 Stroke	150	250	350	450	550	650	750	850	950	1050	1150	1250	1350	1450	1550	1650	1750	1850	1950	2050	2150	2250	2350	2450	2550	2650	2750	2850	2950	3050
L	475	575	675	775	875	975	1075	1175	1275	1375	1475	1575	1675	1775	1875	1975	2075	2175	2275	2375	2475	2575	2675	2775	2875	2975	3075	3175	3275	3375
A	100	200	100	200	100	200	100	200	100	200	100	200	100	200	100	200	100	200	100	200	100	200	100	200	100	200	100	200	100	200
N	6	6	8	8	10	10	12	12	14	14	16	16	18	18	20	20	22	22	24	24	26	26	28	28	30	30	32	32	34	34
M	1	1	2	2	3	3	4	4	5	5	6	6	7	7	8	8	9	9	10	10	11	11	12	12	13	13	14	14	15	15
KG	8.5	9	9.5	10	10.5	11	11.5	12	12.5	13	13.5	14	14.5	15	15.5	16	16.5	17	17.5	18	18.5	19	19.5	20	20.5	21	21.5	22	22.5	23

如有超长行程及定制需求, 请咨询我司业务。 If you have extra long trip and custom requirements, please consult our business.

MEMO

- HNR
- HCR
- HNB
- HC B
- HNT
- XYZ
- ONB
- OCB
- GCR
- GCB
- GCBS
- GCRS
- ESR
- EMR
- EHR
- KSR
- LNP
- DDR
- 参考资料
Reference data



重复精度
Repeat Accuracy
±0.04
mm

此图仅供参考, 出货规格详见尺寸图面
This picture for reference only, specs details according with the drawing.

最大行程
Max stroke 3050mm

最高速度
Max speed 7000mm/s

马达容量
Motor output 750W

直线滑轨
Linear guide 15X12.5-2支

型号表达方式 Ordering method

TPA-HCB-175D-140-L3050-MR-Y-P75-N3-F

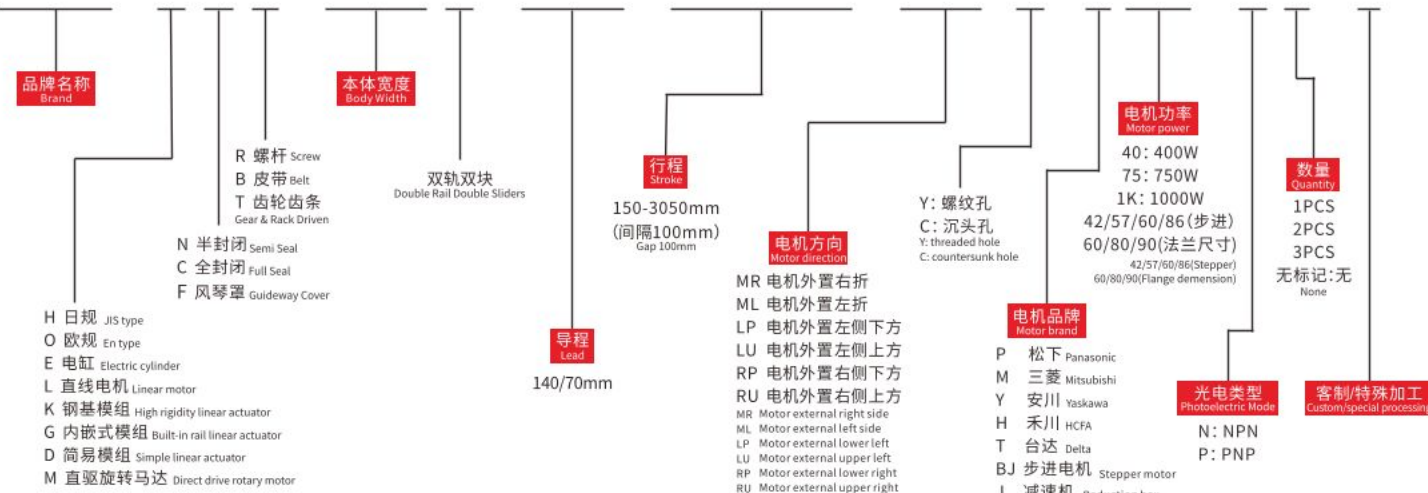

产品性能参数如下 Product performance parameters are as follows

规格 Spec	电机功率 (W) Motor power (W)	750	
	重复定位精度 (mm) Repeated positioning accuracy (mm)	±0.04	
	减速比 (mm) Reduction ratio	1:1	1:2
	导程 (mm) Lead (mm)	140	70
	最高速度 (mm/s) Maximum speed (mm/s)	7000	
	电机额定转速 (RPM) Rated speed of motor (RPM)	3000	
部 品 Parts	最大可搬重量 Maximum Payload	30	60
	标准行程 (mm) Stroke pitch (mm)	150~3050mm/100 间隔 100 mm Pitch	
部 品 Parts	基座材质 Material of base	硬质挤压铝材A1 Hard extruded aluminum A1	
	使用环境 Operating environment	0~40°C, 85%RH(无凝结) No condensation	

注1: 使用非上述功率电机时请依据实际参数推算。
Note 1: When using a motor with a power other than the above, please calculate according to the actual parameters.

注2: 最高速度因行程和负载而异, 当螺杆菌细长比大于1:50时, 可能会因螺杆菌临界速度产生共振和抖动, 应适当下调运行速度, 一般螺杆菌每增长100mm, 速度应下调10~15%。
Note 2: The maximum speed varies with stroke and load. When the screw slenderness ratio is greater than 1:50, resonance and jitter may occur due to the critical speed of the screw, so the running speed should be reduced appropriately. Generally, the speed should be reduced by 10~15% for every 100mm increase of the screw.

容许负载力矩表 N.m Allowable overhang



水平安装 Horizontal installation	A	B	C	侧面安装 Side mounting			
				A	B	C	
负载 Load	10kg	2942	1133	15kg	676	742	1933
	20kg	1430	547	25kg	390	428	1127
	30kg	926	350	35kg	269	294	781
	45kg	588	219	45kg	201	219	588

传感器连接图<原点及端点> Sensor layout

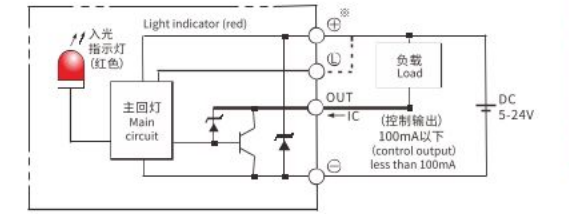

静态容许负载惯量 Static loading moment

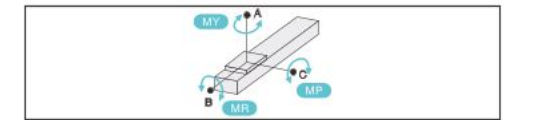

(单位Unit:N.m)	
MY	1032
MP	1034
MR	908

*力矩表所表示的数据, 代表重心。
The torque value in the chart indicate the center of gravity.

*符合型录规范的正常试用下, 保证寿命为10000公里。
Operation life is 10,000km when the product is using under the specified conditions.

*侧吊使用无法套用标准规范, 如有需求请咨询我司业务。
The standard specification cannot be applied to the use of inverted crane. Please consult our business if necessary.

搭配伺服马达一览表 Suitable motor brand

品牌 Brand	马达记号 Mark	刹车有无 Brake	马达容量 Motor capacity	电源电压 AC-Voltage	伺服马达型号 Servo motor model	驱动器型号 Driver Model
三菱 Mitsubishi	M	无刹车(水平式样) No brake (horizontal type)	200	220	HG-KR73	MR-J4-70A
松下 Panasonic	P	无刹车(水平式样) No brake (horizontal type)	200	220	MHMD082G1U	MBDHT3520
台达 Delta	T	无刹车(水平式样) No brake (horizontal type)	200	220	ECMA-C20807ES	ASD-B20721-B



电机外置左侧/电机外置右侧
Motor external left side / Motor external right side

ML 电机外置左侧 Motor external left side

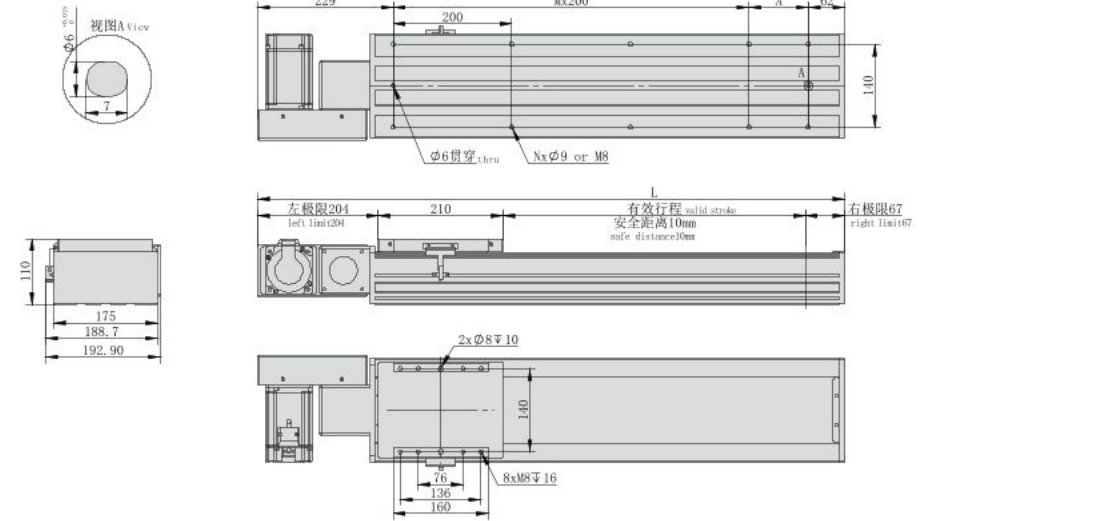

*不含电机重量。*Motor weight not included.

有效行程 Stroke	150	250	350	450	550	650	750	850	950	1050	1150	1250	1350	1450	1550	1650	1750	1850	1950	2050	2150	2250	2350	2450	2550	2650	2750	2850	2950	3050
L	641	741	841	941	1041	1141	1241	1341	1441	1541	1641	1741	1841	1941	2041	2141	2241	2341	2441	2541	2641	2741	2841	2941	3041	3141	3241	3341	3441	3541
A	150	50	150	50	150	50	150	50	150	50	150	50	150	50	150	50	150	50	150	50	150	50	150	50	150	50	150	50	150	50
N	6	8	8	10	10	12	12	14	14	16	16	18	18	20	20	22	22	24	24	26	26	28	28	30	30	32	32	34	34	36
M	2	3	3	4	4	5	5	6	6	7	7	8	8	9	9	10	10	11	11	12	12	13	13	14	14	15	15	16	16	17
KG	10.6	11.6	12.6	13.6	14.6	15.6	16.6	17.6	18.6	19.6	20.6	21.6	22.6	23.6	24.6	25.6	26.6	27.6	28.6	29.6	30.6	31.6	32.6	33.6	34.6	35.6	36.6	37.6	38.6	39.6

如有超长行程及定制需求, 请咨询我司业务。If you have extra long trip and custom requirements, please consult our business.

电机外置左下/电机外置左上
Motor external lower left / Motor external upper left

LP 电机外置左下 Motor external lower left

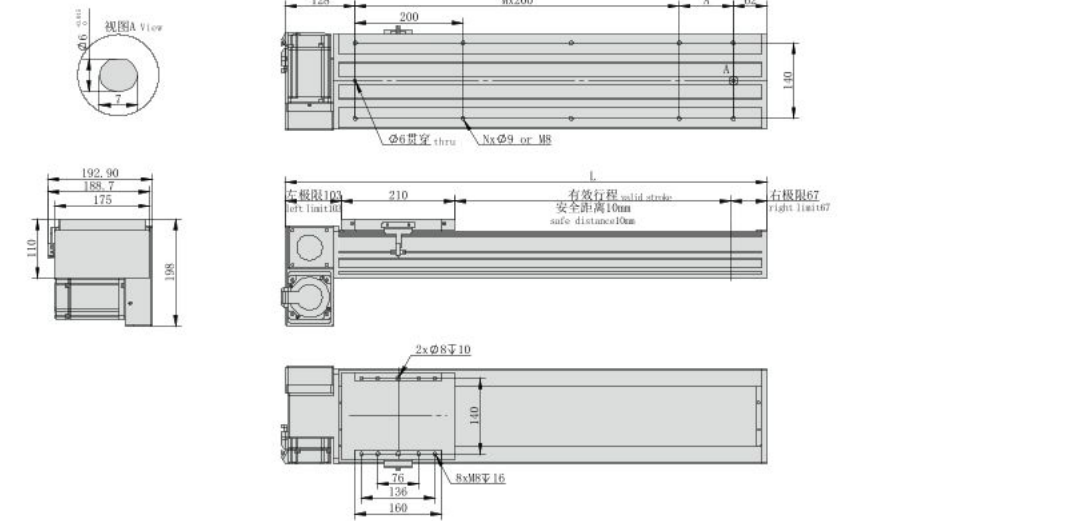

*不含电机重量。*Motor weight not included.

有效行程 Stroke	150	250	350	450	550	650	750	850	950	1050	1150	1250	1350	1450	1550	1650	1750	1850	1950	2050	2150	2250	2350	2450	2550	2650	2750	2850	2950	3050
L	540	640	740	840	940	1040	1140	1240	1340	1440	1540	1640	1740	1840	1940	2040	2140	2240	2340	2440	2540	2640	2740	2840	2940	3040	3140	3240	3340	3440
A	150	50	150	50	150	50	150	50	150	50	150	50	150	50	150	50	150	50	150	50	150	50	150	50	150	50	150	50	150	50
N	6	8	8	10	10	12	12	14	14	16	16	18	18	20	20	22	22	24	24	26	26	28	28	30	30	32	32	34	34	36
M	2	3	3	4	4	5	5	6	6	7	7	8	8	9	9	10	10	11	11	12	12	13	13	14	14	15	15	16	16	17
KG	10.6	11.6	12.6	13.6	14.6	15.6	16.6	17.6	18.6	19.6	20.6	21.6	22.6	23.6	24.6	25.6	26.6	27.6	28.6	29.6	30.6	31.6	32.6	33.6	34.6	35.6	36.6	37.6	38.6	39.6

如有超长行程及定制需求, 请咨询我司业务。If you have extra long trip and custom requirements, please consult our business.

MR 电机外置右侧 Motor external right side

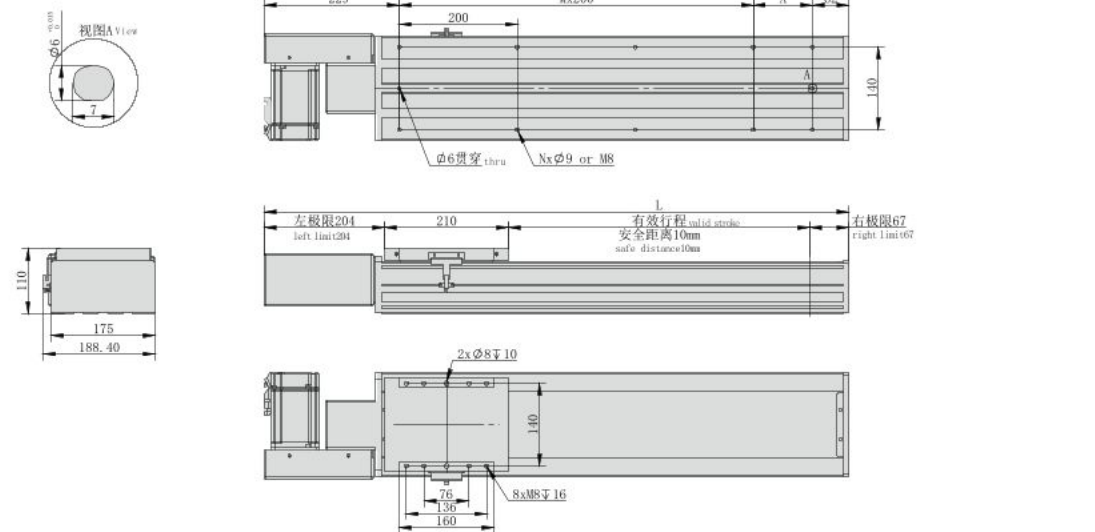

*不含电机重量。*Motor weight not included.

有效行程 Stroke	150	250	350	450	550	650	750	850	950	1050	1150	1250	1350	1450	1550	1650	1750	1850	1950	2050	2150	2250	2350	2450	2550	2650	2750	2850	2950	3050
L	641	741	841	941	1041	1141	1241	1341	1441	1541	1641	1741	1841	1941	2041	2141	2241	2341	2441	2541	2641	2741	2841	2941	3041	3141	3241	3341	3441	3541
A	150	50	150	50	150	50	150	50	150	50	150	50	150	50	150	50	150	50	150	50	150	50	150	50	150	50	150	50	150	50
N	6	8	8	10	10	12	12	14	14	16	16	18	18	20	20	22	22	24	24	26	26	28	28	30	30	32	32	34	34	36
M	2	3	3	4	4	5	5	6	6	7	7	8	8	9	9	10	10	11	11	12	12	13	13	14	14	15	15	16	16	17
KG	10.6	11.6	12.6	13.6	14.6	15.6	16.6	17.6	18.6	19.6	20.6	21.6	22.6	23.6	24.6	25.6	26.6	27.6	28.6	29.6	30.6	31.6	32.6	33.6	34.6	35.6	36.6	37.6	38.6	39.6

如有超长行程及定制需求, 请咨询我司业务。If you have extra long trip and custom requirements, please consult our business.

LU 电机外置左上 Motor external upper left

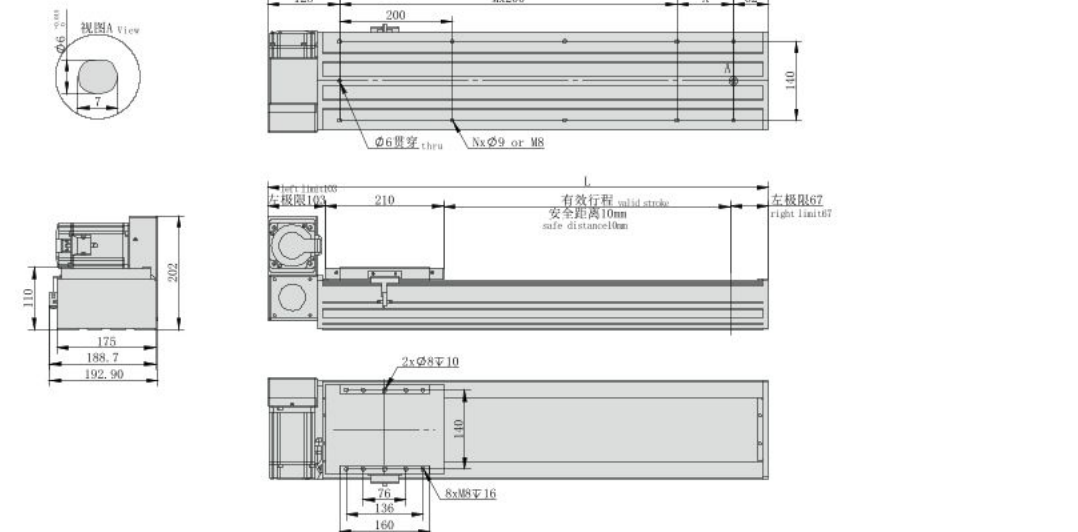

*不含电机重量。*Motor weight not included.

有效行程 Stroke	150	250	350	450	550	650	750	850	950	1050	1150	1250	1350	1450	1550	1650	1750	1850	1950	2050	2150	2250	2350	2450	2550	2650	2750	2850	2950	3050
L	540	640	740	840	940	1040	1140	1240	1340	1440	1540	1640	1740	1840	1940	2040	2140	2240	2340	2440	2540	2640	2740	2840	2940	3040	3140	3240	3340	3440
A	150	50	150	50	150	50	150	50	150	50	150	50	150	50	150	50	150	50	150	50	150	50	150	50	150	50	150	50	150	50
N	6	8	8	10	10	12	12	14	14	16	16	18	18	20	20	22	22	24	24	26	26	28	28	30	30	32	32	34	34	36
M	2	3	3	4	4	5	5	6	6	7	7	8	8	9	9	10	10	11	11	12	12	13	13	14	14	15	15	16	16	17
KG	10.6	11.6	12.6	13.6	14.6	15.6	16.6	17.6	18.6	19.6	20.6	21.6	22.6	23.6	24.6	25.6	26.6	27.6	28.6	29.6	30.6	31.6	32.6	33.6	34.6	35.6	36.6	37.6	38.6	39.6

如有超长行程及定制需求, 请咨询我司业务。If you have extra long trip and custom requirements, please consult our business.

- HNR
- HCR
- HNB
- HC B
- HNT
- XYZ
- ONB
- OCB
- GCR
- GCB
- GCBS
- GCRS
- ESR
- EMR
- EHR
- KSR
- LNP
- DDR

参考资料
Reference data



电机外置右下/电机外置右上
Motor external lower right / Motor external upper right

RP 电机外置右下 Motor external lower right

单位:Unit: mm

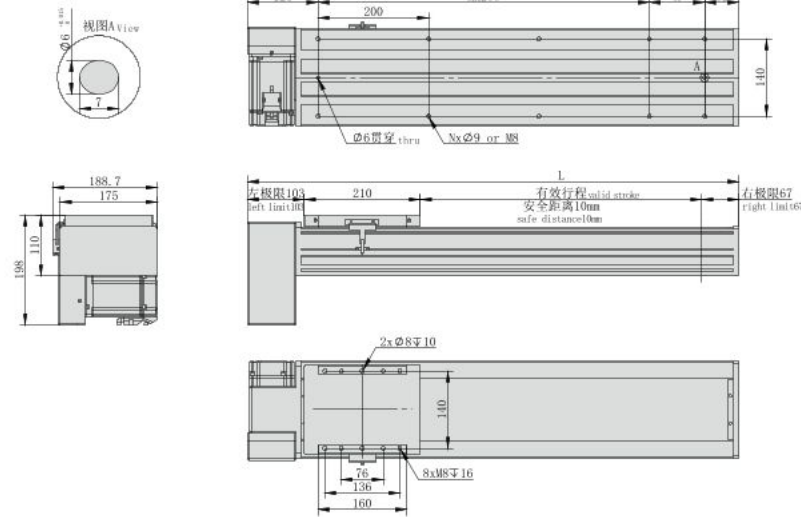

*不含电机重量。*Motor weight not included.

有效行程 Stroke	150	250	350	450	550	650	750	850	950	1050	1150	1250	1350	1450	1550	1650	1750	1850	1950	2050	2150	2250	2350	2450	2550	2650	2750	2850	2950	3050
L	540	640	740	840	940	1040	1140	1240	1340	1440	1540	1640	1740	1840	1940	2040	2140	2240	2340	2440	2540	2640	2740	2840	2940	3040	3140	3240	3340	3440
A	150	50	150	50	150	50	150	50	150	50	150	50	150	50	150	50	150	50	150	50	150	50	150	50	150	50	150	50	150	50
N	6	8	8	10	10	12	12	14	14	16	16	18	18	20	20	22	22	24	24	26	26	28	28	30	30	32	32	34	34	36
M	2	3	3	4	4	5	5	6	6	7	7	8	8	9	9	10	10	11	11	12	12	13	13	14	14	15	15	16	16	17
KG	10.6	11.6	12.6	13.6	14.6	15.6	16.6	17.6	18.6	19.6	20.6	21.6	22.6	23.6	24.6	25.6	26.6	27.6	28.6	29.6	30.6	31.6	32.6	33.6	34.6	35.6	36.6	37.6	38.6	39.6

如有超长行程及定制需求, 请咨询我司业务。 If you have extra long trip and custom requirements, please consult our business.

RU 电机外置右上 Motor external upper right

单位:Unit: mm

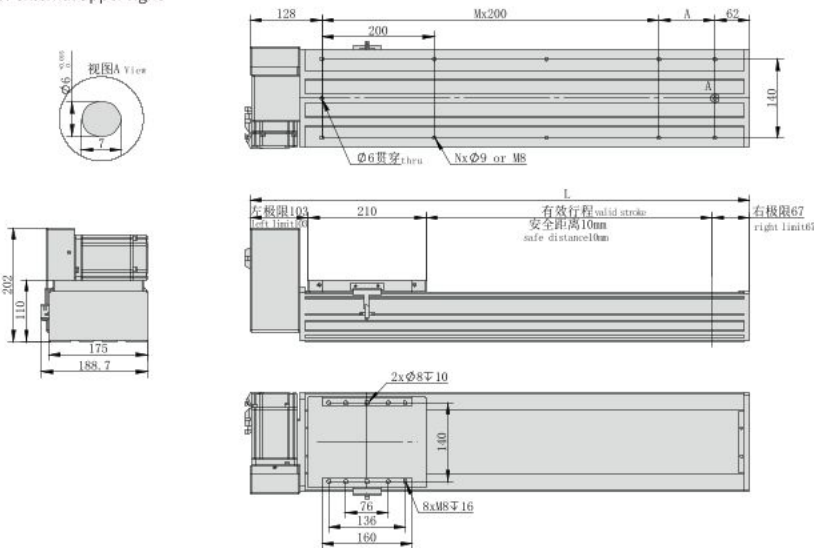

*不含电机重量。*Motor weight not included.

有效行程 Stroke	150	250	350	450	550	650	750	850	950	1050	1150	1250	1350	1450	1550	1650	1750	1850	1950	2050	2150	2250	2350	2450	2550	2650	2750	2850	2950	3050
L	540	640	740	840	940	1040	1140	1240	1340	1440	1540	1640	1740	1840	1940	2040	2140	2240	2340	2440	2540	2640	2740	2840	2940	3040	3140	3240	3340	3440
A	150	50	150	50	150	50	150	50	150	50	150	50	150	50	150	50	150	50	150	50	150	50	150	50	150	50	150	50	150	50
N	6	8	8	10	10	12	12	14	14	16	16	18	18	20	20	22	22	24	24	26	26	28	28	30	30	32	32	34	34	36
M	2	3	3	4	4	5	5	6	6	7	7	8	8	9	9	10	10	11	11	12	12	13	13	14	14	15	15	16	16	17
KG	10.6	11.6	12.6	13.6	14.6	15.6	16.6	17.6	18.6	19.6	20.6	21.6	22.6	23.6	24.6	25.6	26.6	27.6	28.6	29.6	30.6	31.6	32.6	33.6	34.6	35.6	36.6	37.6	38.6	39.6

如有超长行程及定制需求, 请咨询我司业务。 If you have extra long trip and custom requirements, please consult our business.

MEMO

- HNR
- HCR
- HNB
- HCB
- HNT
- XYZ
- ONB
- OCB
- GCR
- GCB
- GCBS
- GCRS
- ESR
- EMR
- EHR
- KSR
- LNP
- DDR
- 参考资料
Reference data



重复精度
Repeat Accuracy
±0.04
mm

此图仅供参考, 出货规格详见尺寸图面
This picture for reference only, specs details according with the drawing.

最大行程
Max stroke 3050mm

最高速度
Max speed 7000mm/s

马达容量
Motor output 750W

直线滑轨
Linear guide 23X18-2支

型号表达方式 Ordering method

TPA-HCB-202D-140-L3050-MR-Y-P75-N3-F

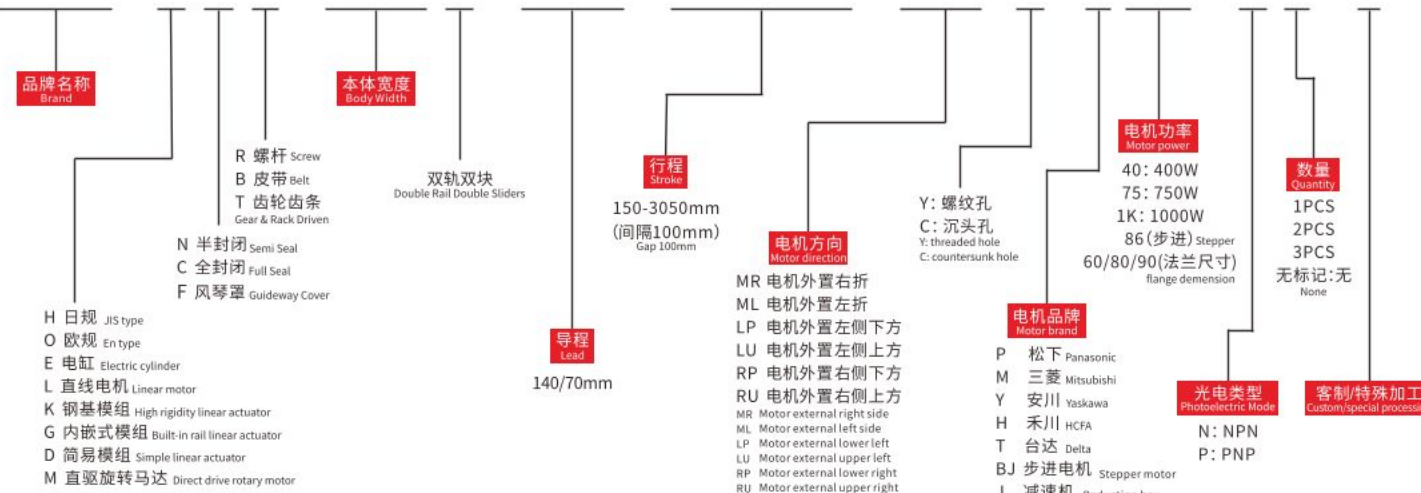

产品性能参数如下 Product performance parameters are as follows

规格 Spec	电机功率 (W) Motor power (W)	750	
	重复定位精度 (mm) Repeated positioning accuracy (mm)	±0.04	
	减速比 (mm) Reduction ratio	1:1	1:2
	导程 (mm) Lead (mm)	140	70
	最高速度 (mm/s) Maximum speed (mm/s)	7000	
	电机额定转速 (RPM) Rated speed of motor (RPM)	3000	
部 品 Parts	最大可搬重量 Maximum Payload	40	80
	标准行程 (mm) Stroke pitch (mm)	150~3050mm/100 间隔 100 mm Pitch	
部 品 Parts	基座材质 Material of base	硬质挤压铝材A1 Hard extruded aluminum A1	
	使用环境 Operating environment	0~40°C, 85%RH(无凝结) No condensation	

注1: 使用非上述功率电机时请依据实际参数推算。
Note 1: When using a motor with a power other than the above, please calculate according to the actual parameters.

注2: 最高速度因行程和负载而异, 当螺杆细长比大于1:50时, 可能会因螺杆临界速度产生共振和抖动, 应适当下调运行速度, 一般螺杆每增长100mm, 速度应下调10~15%。
Note 2: The maximum speed varies with stroke and load. When the screw slenderness ratio is greater than 1:50, resonance and jitter may occur due to the critical speed of the screw, so the running speed should be reduced appropriately. Generally, the speed should be reduced by 10~15% for every 100mm increase of the screw.

传感器连接图<原点及端点> Sensor layout

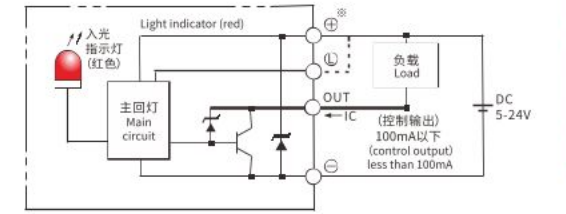

容许负载力矩表 N.m Allowable overhang

负载 Load	水平安装 Horizontal installation			侧面安装 Side mounting		
	A	B	C	A	B	C
45kg	1588	600	349	40kg	500	685
65kg	1052	328	285	60kg	315	430
85kg	768	281	206	85kg	206	281

静态容许负载惯量 Static loading moment

惯量	值 (N.m)
MY	2052
MP	2052
MR	1810

*力矩表所表示的数据, 代表重心。
The torque value in the chart indicate the center of gravity.
*符合型录规范的正常试用下, 保证寿命为10000公里。
Operation life is 10,000km when the product is using under the specified conditions.
*侧吊使用无法套用标准规范, 如有需求请咨询我司业务。
The standard specification cannot be applied to the use of inverted crane. Please consult our business if necessary.

搭配伺服马达一览表 Suitable motor brand

品牌 Brand	马达记号 Mark	刹车有无 Brake	马达容量 Motor capacity	电源电压 AC-Voltage	伺服马达型号 Servo motor model	驱动器型号 Driver Model
三菱 Mitsubishi	M	无刹车(水平式样) No brake (horizontal type)	200	220	HG-KR73	MR-J4-70A
松下 Panasonic	P	无刹车(水平式样) No brake (horizontal type)	200	220	MHMD082G1U	MBDHT3520
台达 Delta	T	无刹车(水平式样) No brake (horizontal type)	200	220	ECMA-C20807ES	ASD-B20721-B

电机外置左侧/电机外置右侧
Motor external left side / Motor external right side

ML 电机外置左侧 Motor external left side

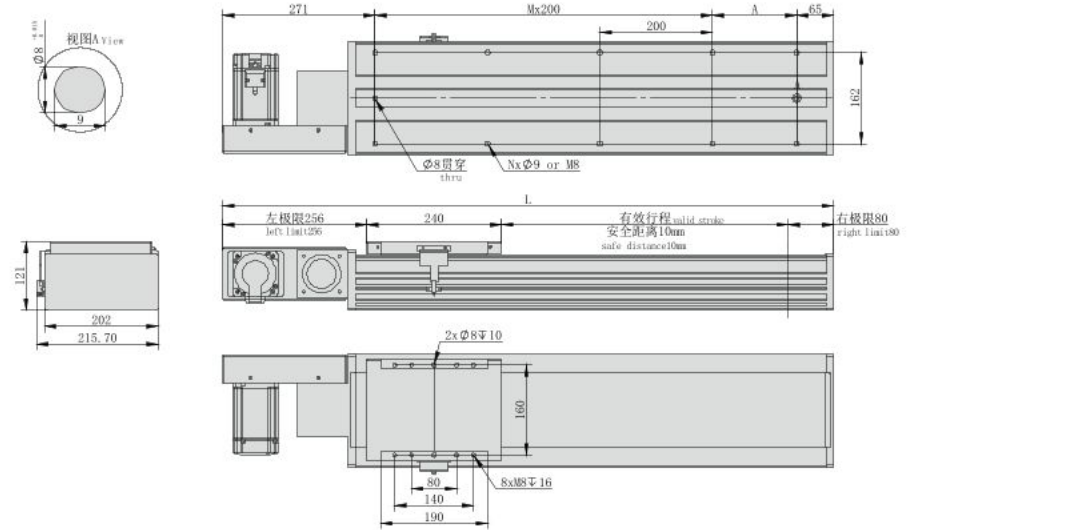

*不含电机重量。*Motor weight not included.

有效行程 Stroke	150	250	350	450	550	650	750	850	950	1050	1150	1250	1350	1450	1550	1650	1750	1850	1950	2050	2150	2250	2350	2450	2550	2650	2750	2850	2950	3050
L	736	836	936	1036	1136	1236	1336	1436	1536	1636	1736	1836	1936	2036	2136	2236	2336	2436	2536	2636	2736	2836	2936	3036	3136	3236	3336	3436	3536	3636
A	200	100	200	100	200	100	200	100	200	100	200	100	200	100	200	100	200	100	200	100	200	100	200	100	200	100	200	100	200	100
N	6	8	8	10	10	12	12	14	14	16	16	18	18	20	20	22	22	24	24	26	26	28	28	30	30	32	32	34	34	36
M	1	2	2	3	3	4	4	5	5	6	6	7	7	8	8	9	9	10	10	11	11	12	12	13	13	14	14	15	15	16
KG	21.5	23	24.5	26	27.5	29	30.5	32	33.5	35	36.5	38	39.5	41	42.5	44	45.5	47	48.5	50	51.5	53	54.5	56	57.5	59	60.5	62	63.5	65

如有超长行程及定制需求, 请咨询我司业务。 If you have extra long trip and custom requirements, please consult our business.

电机外置左下/电机外置左上
Motor external lower left / Motor external upper left

LP 电机外置左下 Motor external lower left

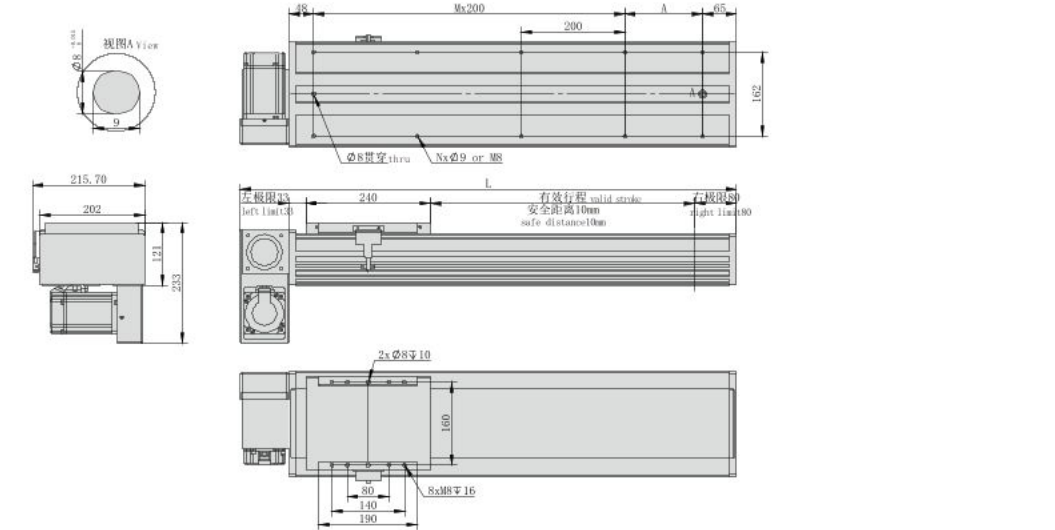

*不含电机重量。*Motor weight not included.

有效行程 Stroke	150	250	350	450	550	650	750	850	950	1050	1150	1250	1350	1450	1550	1650	1750	1850	1950	2050	2150	2250	2350	2450	2550	2650	2750	2850	2950	3050
L	513	613	713	813	913	1013	1113	1213	1313	1413	1513	1613	1713	1813	1913	2013	2113	2213	2313	2413	2513	2613	2713	2813	2913	3013	3113	3213	3313	3413
A	200	100	200	100	200	100	200	100	200	100	200	100	200	100	200	100	200	100	200	100	200	100	200	100	200	100	200	100	200	100
N	6	8	8	10	10	12	12	14	14	16	16	18	18	20	20	22	22	24	24	26	26	28	28	30	30	32	32	34	34	36
M	1	2	2	3	3	4	4	5	5	6	6	7	7	8	8	9	9	10	10	11	11	12	12	13	13	14	14	15	15	16
KG	21.5	23	24.5	26	27.5	29	30.5	32	33.5	35	36.5	38	39.5	41	42.5	44	45.5	47	48.5	50	51.5	53	54.5	56	57.5	59	60.5	62	63.5	65

如有超长行程及定制需求, 请咨询我司业务。 If you have extra long trip and custom requirements, please consult our business.

MR 电机外置右侧 Motor external right side

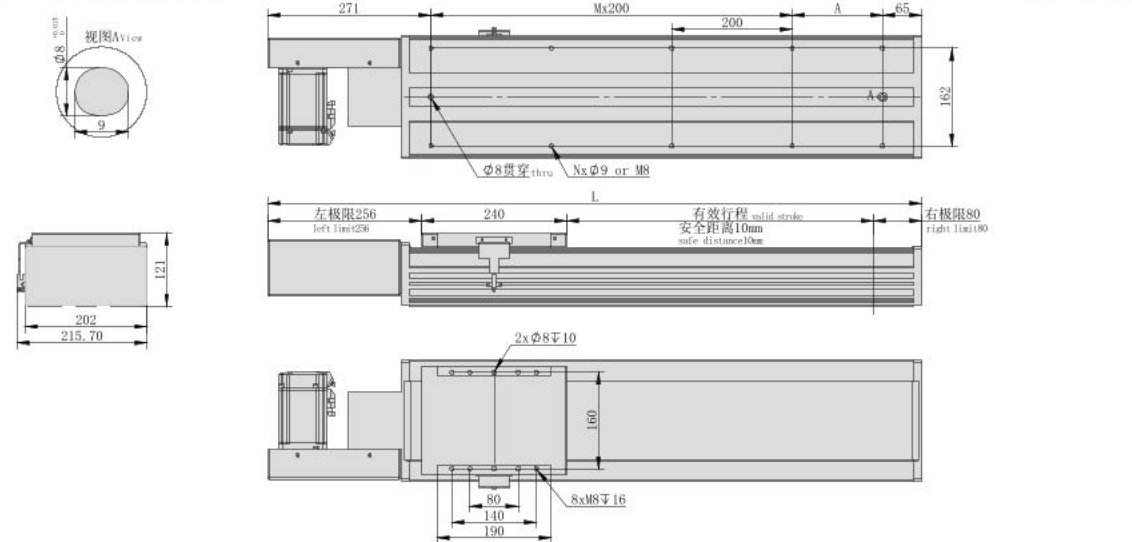

*不含电机重量。*Motor weight not included.

有效行程 Stroke	150	250	350	450	550	650	750	850	950	1050	1150	1250	1350	1450	1550	1650	1750	1850	1950	2050	2150	2250	2350	2450	2550	2650	2750	2850	2950	3050
L	736	836	936	1036	1136	1236	1336	1436	1536	1636	1736	1836	1936	2036	2136	2236	2336	2436	2536	2636	2736	2836	2936	3036	3136	3236	3336	3436	3536	3636
A	200	100	200	100	200	100	200	100	200	100	200	100	200	100	200	100	200	100	200	100	200	100	200	100	200	100	200	100	200	100
N	6	8	8	10	10	12	12	14	14	16	16	18	18	20	20	22	22	24	24	26	26	28	28	30	30	32	32	34	34	36
M	1	2	2	3	3	4	4	5	5	6	6	7	7	8	8	9	9	10	10	11	11	12	12	13	13	14	14	15	15	16
KG	21.5	23	24.5	26	27.5	29	30.5	32	33.5	35	36.5	38	39.5	41	42.5	44	45.5	47	48.5	50	51.5	53	54.5	56	57.5	59	60.5	62	63.5	65

如有超长行程及定制需求, 请咨询我司业务。 If you have extra long trip and custom requirements, please consult our business.

LU 电机外置左上 Motor external upper left

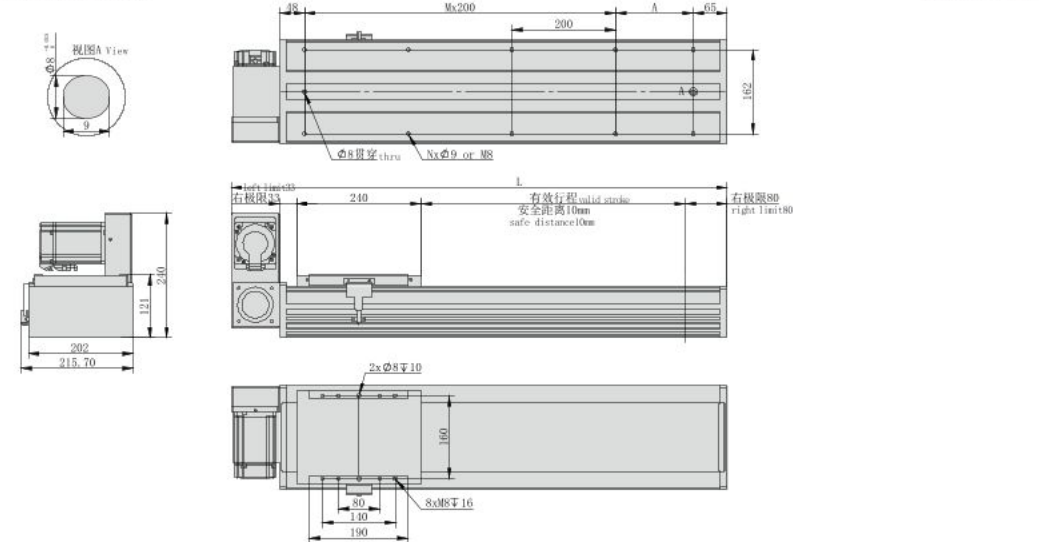

*不含电机重量。*Motor weight not included.

有效行程 Stroke	150	250	350	450	550	650	750	850	950	1050	1150	1250	1350	1450	1550	1650	1750	1850	1950	2050	2150	2250	2350	2450	2550	2650	2750	2850	2950	3050
L	513	613	713	813	913	1013	1113	1213	1313	1413	1513	1613	1713	1813	1913	2013	2113	2213	2313	2413	2513	2613	2713	2813	2913	3013	3113	3213	3313	3413
A	200	100	200	100	200	100	200	100	200	100	200	100	200	100	200	100	200	100	200	100	200	100	200	100	200	100	200	100	200	100
N	6	8	8	10	10	12	12	14	14	16	16	18	18	20	20	22	22	24	24	26	26	28	28	30	30	32	32	34	34	36
M	1	2	2	3	3	4	4	5	5	6	6	7	7	8	8	9	9	10	10	11	11	12	12	13	13	14	14	15	15	16
KG	21.5	23	24.5	26	27.5	29	30.5	32	33.5	35	36.5	38	39.5	41	42.5	44	45.5	47	48.5	50	51.5	53	54.5	56	57.5	59	60.5	62	63.5	65

如有超长行程及定制需求, 请咨询我司业务。 If you have extra long trip and custom requirements, please consult our business.

- HNR
- HCR
- HNB
- HC B
- HNT
- XYZ
- ONB
- OCB
- GCR
- GCB
- GCBS
- GCRS
- ESR
- EMR
- EHR
- KSR
- LNP
- DDR

参考资料
Reference data



电机外置右下/电机外置右上
Motor external lower right / Motor external upper right

RP 电机外置右下 Motor external lower right

单位:Unit: mm

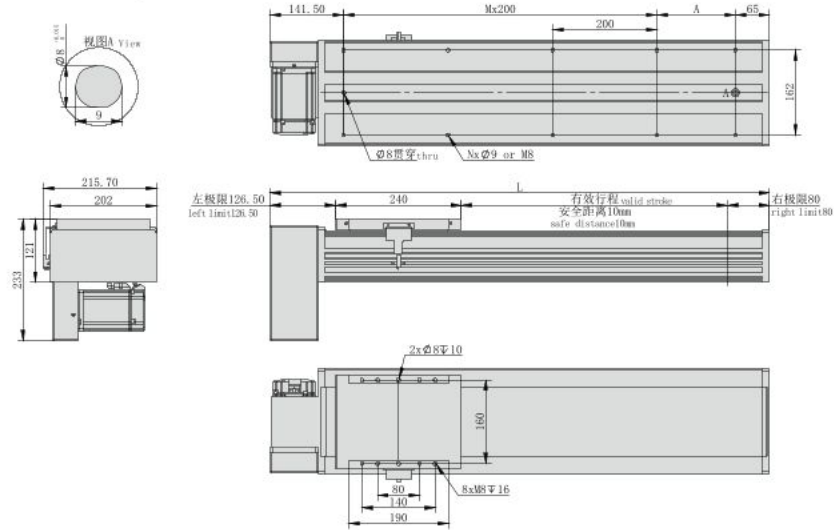

*不含电机重量。*Motor weight not included.

有效行程 Stroke	150	250	350	450	550	650	750	850	950	1050	1150	1250	1350	1450	1550	1650	1750	1850	1950	2050	2150	2250	2350	2450	2550	2650	2750	2850	2950	3050
L	513	613	713	813	913	1013	1113	1213	1313	1413	1513	1613	1713	1813	1913	2013	2113	2213	2313	2413	2513	2613	2713	2813	2913	3013	3113	3213	3313	3413
A	200	100	200	100	200	100	200	100	200	100	200	100	200	100	200	100	200	100	200	100	200	100	200	100	200	100	200	100	200	100
N	6	8	8	10	10	12	12	14	14	16	16	18	18	20	20	22	22	24	24	26	26	28	28	30	30	32	32	34	34	36
M	1	2	2	3	3	4	4	5	5	6	6	7	7	8	8	9	9	10	10	11	11	12	12	13	13	14	14	15	15	16
KG	21.5	23	24.5	26	27.5	29	30.5	32	33.5	35	36.5	38	39.5	41	42.5	44	45.5	47	48.5	50	51.5	53	54.5	56	57.5	59	60.5	62	63.5	65

如有超长行程及定制需求, 请咨询我司业务。If you have extra long trip and custom requirements, please consult our business.

RU 电机外置右上 Motor external upper right

单位:Unit: mm

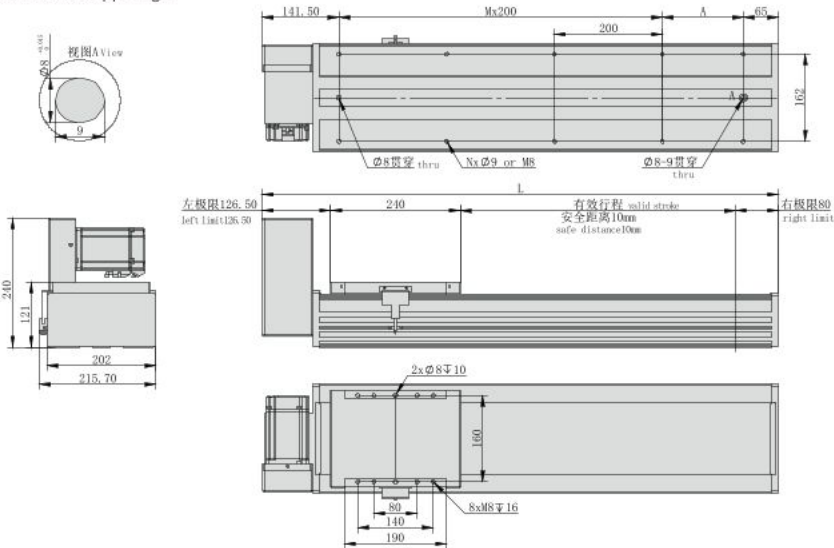

*不含电机重量。*Motor weight not included.

有效行程 Stroke	150	250	350	450	550	650	750	850	950	1050	1150	1250	1350	1450	1550	1650	1750	1850	1950	2050	2150	2250	2350	2450	2550	2650	2750	2850	2950	3050
L	513	613	713	813	913	1013	1113	1213	1313	1413	1513	1613	1713	1813	1913	2013	2113	2213	2313	2413	2513	2613	2713	2813	2913	3013	3113	3213	3313	3413
A	200	100	200	100	200	100	200	100	200	100	200	100	200	100	200	100	200	100	200	100	200	100	200	100	200	100	200	100	200	100
N	6	8	8	10	10	12	12	14	14	16	16	18	18	20	20	22	22	24	24	26	26	28	28	30	30	32	32	34	34	36
M	1	2	2	3	3	4	4	5	5	6	6	7	7	8	8	9	9	10	10	11	11	12	12	13	13	14	14	15	15	16
KG	21.5	23	24.5	26	27.5	29	30.5	32	33.5	35	36.5	38	39.5	41	42.5	44	45.5	47	48.5	50	51.5	53	54.5	56	57.5	59	60.5	62	63.5	65

如有超长行程及定制需求, 请咨询我司业务。If you have extra long trip and custom requirements, please consult our business.

MEMO

- HNR
- HCR
- HNB
- HC B
- HNT
- XYZ
- ONB
- OCB
- GCR
- GCB
- GCBS
- GCRS
- ESR
- EMR
- EHR
- KSR
- LNP
- DDR
- 参考资料
Reference data



重复精度
Repeat Accuracy
±0.04
mm

此图仅供参考, 出货规格详见尺寸图面
This picture for reference only, specs details according with the drawing.

最大行程
Max stroke 3050mm

最高速度
Max speed 8800mm/s

马达容量
Motor output 1000W

直线滑轨
Linear guide 23X18-2支

型号表达方式 Ordering method

TPA-HCB-220D-176-L3050-MR-Y-P1K-N3-F

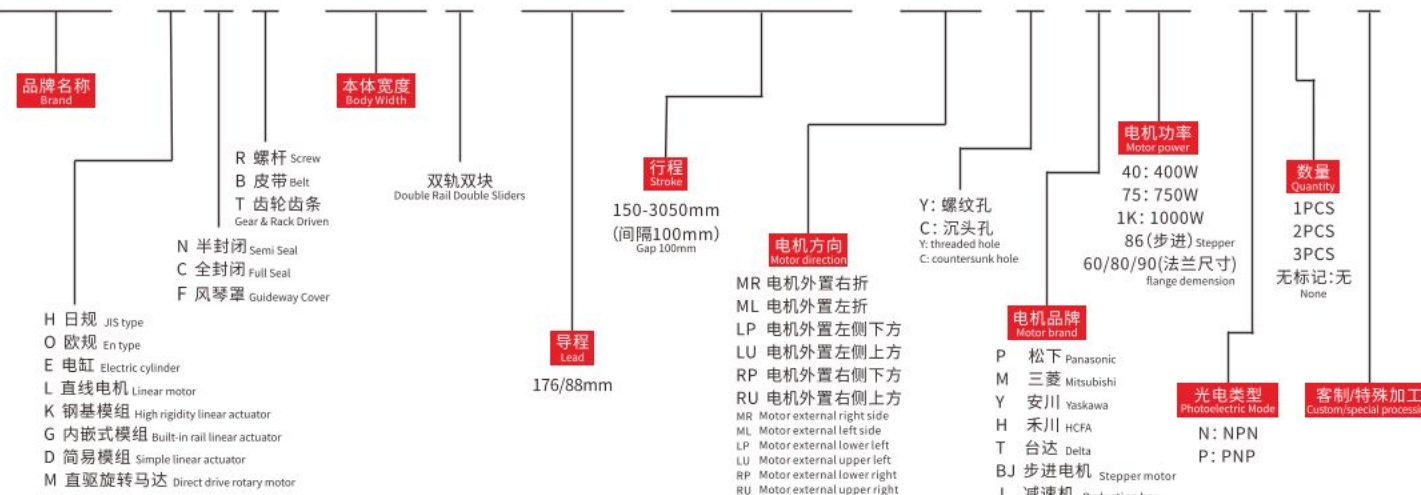

产品性能参数如下 Product performance parameters are as follows

规格 Spec	电机功率 (W) Motor power (W)	1000	
	重复定位精度 (mm) Repeated positioning accuracy (mm)	±0.04	
	减速比 (mm) Reduction ratio	1:1	1:2
	导程 (mm) Lead (mm)	176	88
	最高速度 (mm/s) Maximum speed (mm/s)	8800	
	电机额定转速 (RPM) Rated speed of motor (RPM)	3000	
部 品 Parts	最大可搬重量 Maximum Payload	50	100
	标准行程 (mm) Stroke pitch (mm)	150-3050mm/100 间隔100 mm Pitch	
	基座材质 Material of base	硬质挤压铝材A1 Hard extruded aluminum A1	
使用环境 Operating environment	0~40°C, 85%RH(无凝结) No condensation		

注1: 使用非上述功率电机时请依据实际参数推算。
Note 1: When using a motor with a power other than the above, please calculate according to the actual parameters.
注2: 最高速度因行程和负载而异, 当螺杆细长比大于1:50时, 可能会因螺杆临界速度产生共振和抖动, 应适当下调运行速度, 一般螺杆每增长100mm, 速度应下调10~15%。
Note 2: The maximum speed varies with stroke and load. When the screw slenderness ratio is greater than 1:50, resonance and jitter may occur due to the critical speed of the screw, so the running speed should be reduced appropriately. Generally, the speed should be reduced by 10~15% for every 100mm increase of the screw.

传感器连接图<原点及端点> Sensor layout

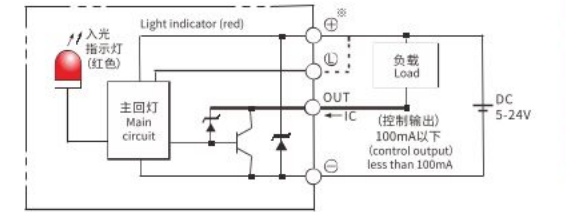

容许负载力矩表 N.m Allowable overhang

负载 Load	水平安装 Horizontal installation			侧面安装 Side mounting		
	A	B	C	A	B	C
45kg	3444	1015	1358	45kg	1410	3435
65kg	2460	725	970	65kg	1010	2455
85kg	1800	550	740	85kg	770	1886

静态容许负载惯量 Static loading moment

MY	MP	MR
2052	2052	1810

*力矩表所表示的数据, 代表重心。
The torque value in the chart indicate the center of gravity.
*符合型录规范的正常试用下, 保证寿命为10000公里。
Operation life is 10,000km when the product is using under the specified conditions.
*侧吊使用无法套用标准规范, 如有需求请咨询我司业务。
The standard specification cannot be applied to the use of inverted crane. Please consult our business if necessary.

搭配伺服马达一览表 Suitable motor brand

品牌 Brand	马达记号 Mark	刹车有无 Brake	马达容量 Motor capacity	电源电压 AC-Voltage	伺服马达型号 Servo motor model	驱动器型号 Driver Model
三菱 Mitsubishi	M	无刹车(水平式样) No brake (horizontal type)	200	220	HG-KR73	MR-J4-70A
松下 Panasonic	P	无刹车(水平式样) No brake (horizontal type)	200	220	MHMD082G1U	MBDHT3520
台达 Delta	T	无刹车(水平式样) No brake (horizontal type)	200	220	ECMA-C20807ES	ASD-B20721-B



电机外置左侧/电机外置右侧
Motor external left side / Motor external right side

ML 电机外置左侧 Motor external left side

单位:Unit: mm

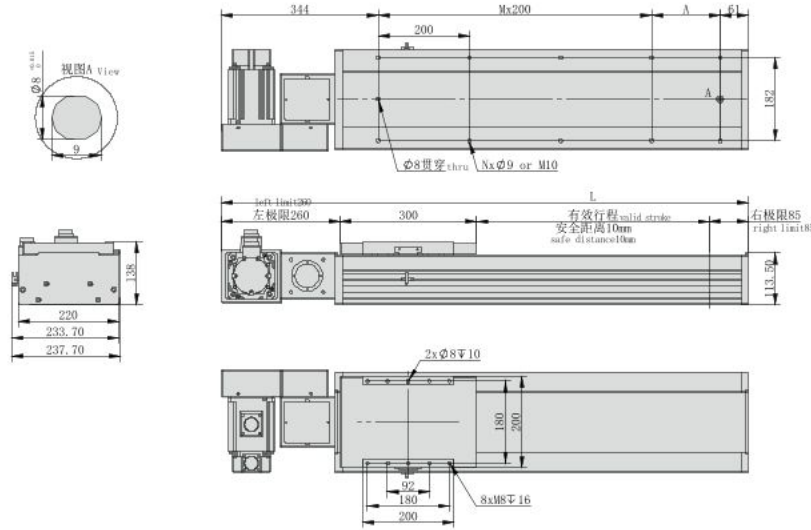

*不含电机重量。*Motor weight not included.

有效行程 Stroke	150	250	350	450	550	650	750	850	950	1050	1150	1250	1350	1450	1550	1650	1750	1850	1950	2050	2150	2250	2350	2450	2550	2650	2750	2850	2950	3050
L	805	905	1005	1105	1205	1305	1405	1505	1605	1705	1805	1905	2005	2105	2205	2305	2405	2505	2605	2705	2805	2905	3005	3105	3205	3305	3405	3505	3605	3705
A	50	150	50	150	50	150	50	150	50	150	50	150	50	150	50	150	50	150	50	150	50	150	50	150	50	150	50	150	50	150
N	6	6	8	8	10	10	12	12	14	14	16	16	18	18	20	20	22	22	24	24	26	26	28	28	30	30	32	32	34	34
M	2	2	3	3	4	4	5	5	6	6	7	7	8	8	9	9	10	10	11	11	12	12	13	13	14	14	15	15	16	16
KG	25.6	27.5	29.4	31.3	33.2	35.1	37	38.9	40.8	42.7	44.6	46.5	48.4	50.3	52.2	54.1	56	57.9	59.8	61.7	63.6	65.5	67.4	69.3	71.2	73.1	75	76.9	78.8	80.7

如有超长行程及定制需求, 请咨询我司业务。 If you have extra long trip and custom requirements, please consult our business.

电机外置左下/电机外置左上
Motor external lower left / Motor external upper left

LP 电机外置左下 Motor external lower left

单位:Unit: mm

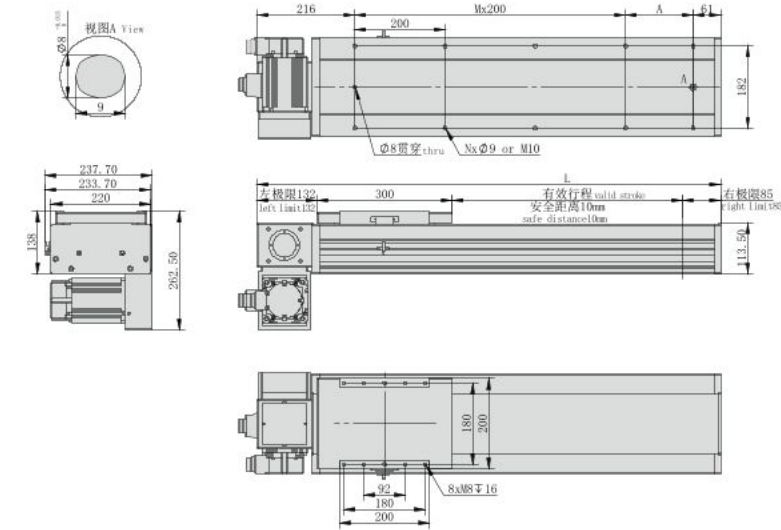

*不含电机重量。*Motor weight not included.

有效行程 Stroke	150	250	350	450	550	650	750	850	950	1050	1150	1250	1350	1450	1550	1650	1750	1850	1950	2050	2150	2250	2350	2450	2550	2650	2750	2850	2950	3050
L	677	777	877	977	1077	1177	1277	1377	1477	1577	1677	1777	1877	1977	2077	2177	2277	2377	2477	2577	2677	2777	2877	2977	3077	3177	3277	3377	3477	3577
A	50	150	50	150	50	150	50	150	50	150	50	150	50	150	50	150	50	150	50	150	50	150	50	150	50	150	50	150	50	150
N	6	6	8	8	10	10	12	12	14	14	16	16	18	18	20	20	22	22	24	24	26	26	28	28	30	30	32	32	34	34
M	2	2	3	3	4	4	5	5	6	6	7	7	8	8	9	9	10	10	11	11	12	12	13	13	14	14	15	15	16	16
KG	25.6	27.5	29.4	31.3	33.2	35.1	37	38.9	40.8	42.7	44.6	46.5	48.4	50.3	52.2	54.1	56	57.9	59.8	61.7	63.6	65.5	67.4	69.3	71.2	73.1	75	76.9	78.8	80.7

如有超长行程及定制需求, 请咨询我司业务。 If you have extra long trip and custom requirements, please consult our business.

MR 电机外置右侧 Motor external right side

单位:Unit: mm

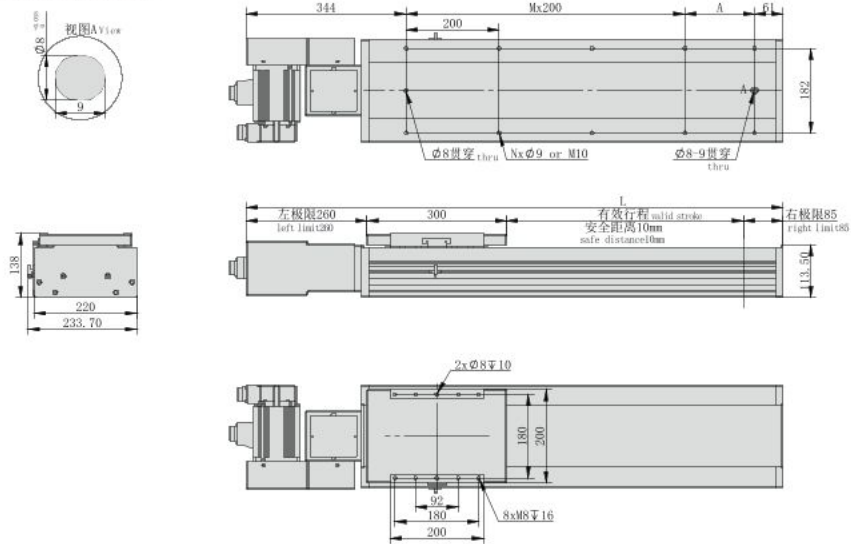

*不含电机重量。*Motor weight not included.

有效行程 Stroke	150	250	350	450	550	650	750	850	950	1050	1150	1250	1350	1450	1550	1650	1750	1850	1950	2050	2150	2250	2350	2450	2550	2650	2750	2850	2950	3050
L	805	905	1005	1105	1205	1305	1405	1505	1605	1705	1805	1905	2005	2105	2205	2305	2405	2505	2605	2705	2805	2905	3005	3105	3205	3305	3405	3505	3605	3705
A	50	150	50	150	50	150	50	150	50	150	50	150	50	150	50	150	50	150	50	150	50	150	50	150	50	150	50	150	50	150
N	6	6	8	8	10	10	12	12	14	14	16	16	18	18	20	20	22	22	24	24	26	26	28	28	30	30	32	32	34	34
M	2	2	3	3	4	4	5	5	6	6	7	7	8	8	9	9	10	10	11	11	12	12	13	13	14	14	15	15	16	16
KG	25.6	27.5	29.4	31.3	33.2	35.1	37	38.9	40.8	42.7	44.6	46.5	48.4	50.3	52.2	54.1	56	57.9	59.8	61.7	63.6	65.5	67.4	69.3	71.2	73.1	75	76.9	78.8	80.7

如有超长行程及定制需求, 请咨询我司业务。 If you have extra long trip and custom requirements, please consult our business.

LU 电机外置左上 Motor external upper left

单位:Unit: mm

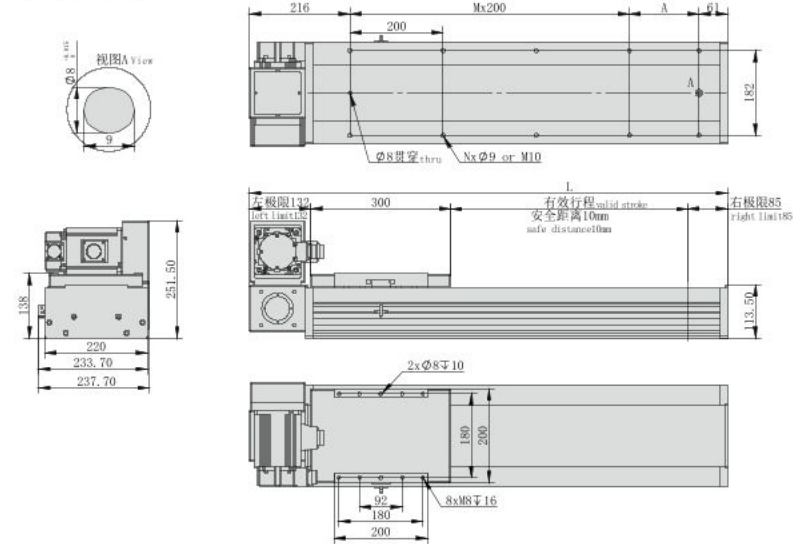

*不含电机重量。*Motor weight not included.

有效行程 Stroke	150	250	350	450	550	650	750	850	950	1050	1150	1250	1350	1450	1550	1650	1750	1850	1950	2050	2150	2250	2350	2450	2550	2650	2750	2850	2950	3050
L	677	777	877	977	1077	1177	1277	1377	1477	1577	1677	1777	1877	1977	2077	2177	2277	2377	2477	2577	2677	2777	2877	2977	3077	3177	3277	3377	3477	3577
A	50	150	50	150	50	150	50	150	50	150	50	150	50	150	50	150	50	150	50	150	50	150	50	150	50	150	50	150	50	150
N	6	6	8	8	10	10	12	12	14	14	16	16	18	18	20	20	22	22	24	24	26	26	28	28	30	30	32	32	34	34
M	2	2	3	3	4	4	5	5	6	6	7	7	8	8	9	9	10	10	11	11	12	12	13	13	14	14	15	15	16	16
KG	25.6	27.5	29.4	31.3	33.2	35.1	37	38.9	40.8	42.7	44.6	46.5	48.4	50.3	52.2	54.1	56	57.9	59.8	61.7	63.6	65.5	67.4	69.3	71.2	73.1	75	76.9	78.8	80.7

如有超长行程及定制需求, 请咨询我司业务。 If you have extra long trip and custom requirements, please consult our business.

- HNR
- HCR
- HNB
- HC B
- HNT
- XYZ
- ONB
- OCB
- GCR
- GCB
- GCBS
- GCRS
- ESR
- EMR
- EHR
- KSR
- LNP
- DDR

参考资料
Reference data



电机外置右下/电机外置右上
Motor external lower right / Motor external upper right

RP 电机外置右下 Motor external lower right

单位:Unit: mm

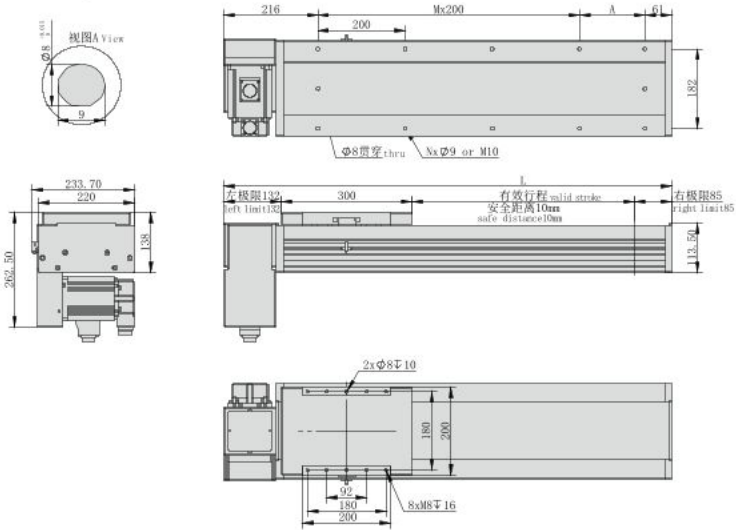

*不含电机重量。*Motor weight not included.

有效行程 Stroke	150	250	350	450	550	650	750	850	950	1050	1150	1250	1350	1450	1550	1650	1750	1850	1950	2050	2150	2250	2350	2450	2550	2650	2750	2850	2950	3050
L	677	777	877	977	1077	1177	1277	1377	1477	1577	1677	1777	1877	1977	2077	2177	2277	2377	2477	2577	2677	2777	2877	2977	3077	3177	3277	3377	3477	3577
A	50	150	50	150	50	150	50	150	50	150	50	150	50	150	50	150	50	150	50	150	50	150	50	150	50	150	50	150	50	150
N	6	6	8	8	10	10	12	12	14	14	16	16	18	18	20	20	22	22	24	24	26	26	28	28	30	30	32	32	34	34
M	2	2	3	3	4	4	5	5	6	6	7	7	8	8	9	9	10	10	11	11	12	12	13	13	14	14	15	15	16	16
KG	25.6	27.5	29.4	31.3	33.2	35.1	37	38.9	40.8	42.7	44.6	46.5	48.4	50.3	52.2	54.1	56	57.9	59.8	61.7	63.6	65.5	67.4	69.3	71.2	73.1	75	76.9	78.8	80.7

如有超长行程及定制需求,请咨询我司业务。If you have extra long trip and custom requirements, please consult our business.

RU 电机外置右上 Motor external upper right

单位:Unit: mm

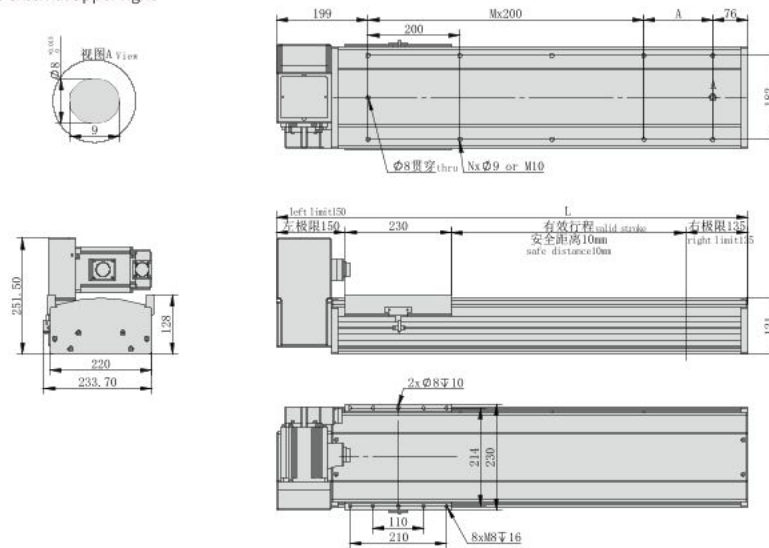

*不含电机重量。*Motor weight not included.

有效行程 Stroke	150	250	350	450	550	650	750	850	950	1050	1150	1250	1350	1450	1550	1650	1750	1850	1950	2050	2150	2250	2350	2450	2550	2650	2750	2850	2950	3050
L	677	777	877	977	1077	1177	1277	1377	1477	1577	1677	1777	1877	1977	2077	2177	2277	2377	2477	2577	2677	2777	2877	2977	3077	3177	3277	3377	3477	3577
A	50	150	50	150	50	150	50	150	50	150	50	150	50	150	50	150	50	150	50	150	50	150	50	150	50	150	50	150	50	150
N	6	6	8	8	10	10	12	12	14	14	16	16	18	18	20	20	22	22	24	24	26	26	28	28	30	30	32	32	34	34
M	2	2	3	3	4	4	5	5	6	6	7	7	8	8	9	9	10	10	11	11	12	12	13	13	14	14	15	15	16	16
KG	25.6	27.5	29.4	31.3	33.2	35.1	37	38.9	40.8	42.7	44.6	46.5	48.4	50.3	52.2	54.1	56	57.9	59.8	61.7	63.6	65.5	67.4	69.3	71.2	73.1	75	76.9	78.8	80.7

如有超长行程及定制需求,请咨询我司业务。If you have extra long trip and custom requirements, please consult our business.

MEMO

- HNR
- HCR
- HNB
- HC B
- HNT
- XYZ
- ONB
- OCB
- GCR
- GCB
- GCBS
- GCRS
- ESR
- EMR
- EHR
- KSR
- LNP
- DDR
- 参考资料
Reference data



重复精度
Repeat Accuracy
±0.04
mm

此图仅供参考, 出货规格详见尺寸图面
This picture for reference only, specs details according with the drawing.

最大行程
Max stroke 3050mm

最高速度
Max speed 7000mm/s

马达容量
Motor output 1000W

直线滑轨
Linear guide 23X18-2支

型号表达方式 Ordering method

TPA-HCB-270D-140-L3050-MR-Y-P1K-N3-F

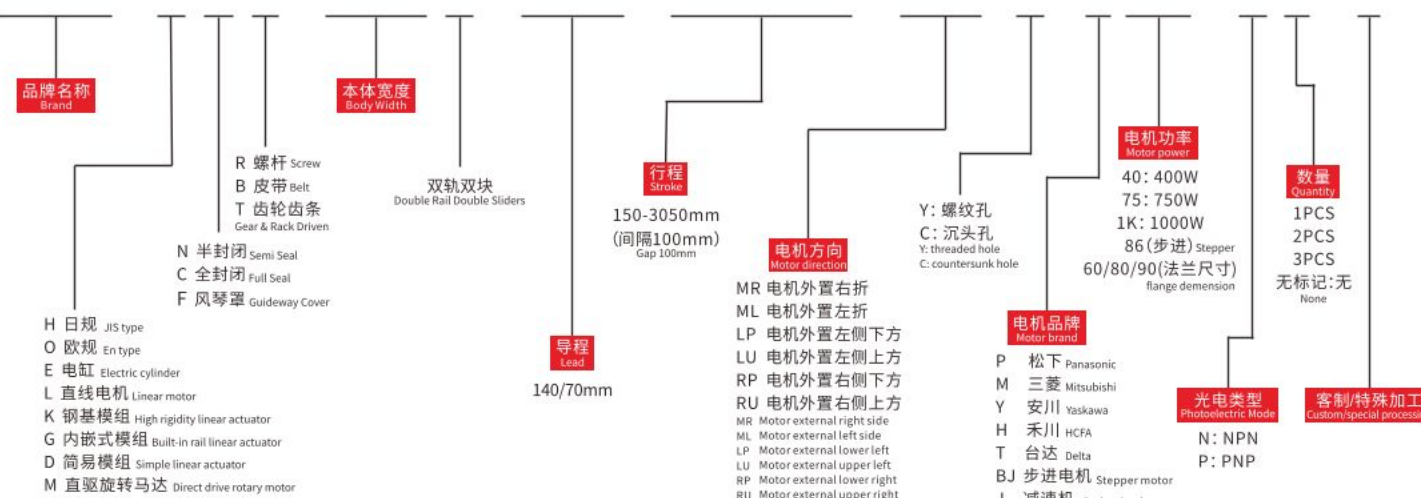

产品性能参数如下 Product performance parameters are as follows

电机功率 (W) Motor power (W)	1000	
重复定位精度 (mm) Repeated positioning accuracy (mm)	±0.04	
减速比 (mm) Reduction ratio	1:1	1:2
规格 导程 (mm) Lead (mm)	140	70
最高速度 (mm/s) Maximum speed (mm/s)	7000	
电机额定转速 (RPM) Rated speed of motor (RPM)	3000	
最大可搬重量 Maximum Payload	70	140
标准行程 (mm) Stroke pitch (mm)	150~3050mm/100 间隔100 mm Pitch	
部品 基座材质 Material of base	硬质挤压铝材A1 Hard extruded aluminum A1	
使用环境 Operating environment	0~40°C, 85%RH(无凝结) No condensation	

注1: 使用非上述功率电机时请依据实际参数推算。
Note 1: When using a motor with a power other than the above, please calculate according to the actual parameters.
注2: 最高速度因行程和负载而异, 当螺杆细长比大于1:50时, 可能会因螺杆临界速度产生共振和抖动, 应适当下调运行速度, 一般螺杆每增长100mm, 速度应下调10~15%。
Note 2: The maximum speed varies with stroke and load. When the screw slenderness ratio is greater than 1:50, resonance and jitter may occur due to the critical speed of the screw, so the running speed should be reduced appropriately. Generally, the speed should be reduced by 10~15% for every 100mm increase of the screw.

传感器连接图<原点及端点> Sensor layout

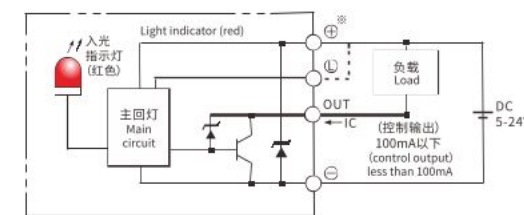

容许负载力矩表 N.m Allowable overhang

负载 Load	水平安装 Horizontal installation			侧面安装 Side mounting		
	A	B	C	A	B	C
90kg	1579	605	336	90kg	485	682
115kg	1136	328	283	115kg	318	420
140kg	771	269	210	140kg	205	281

静态容许负载惯量 Static loading moment

惯量 Inertia	静态容许负载惯量 Static loading moment (N.m)
MY	3223
MP	3223
MR	2843

*力矩表所表示的数据, 代表重心。
The torque value in the chart indicate the center of gravity.
*符合型录规范的正常试用下, 保证寿命为10000公里。
Operation life is 10,000km when the product is using under the specified conditions.
*侧吊使用无法套用标准规范, 如有需求请咨询我司业务。
The standard specification cannot be applied to the use of inverted crane. Please consult our business if necessary.

搭配伺服马达一览表 Suitable motor brand

品牌 Brand	马达记号 Mark	刹车有无 Brake	马达容量 Motor capacity	电源电压 AC-Voltage	伺服马达型号 Servo motor model	驱动器型号 Driver Model
三菱 Mitsubishi	M	无刹车(水平式样) No brake (horizontal type)	200	220	HG-KR73	MR-J4-70A
松下 Panasonic	P	无刹车(水平式样) No brake (horizontal type)	200	220	MHMD082G1U	MBDHT3520
台达 Delta	T	无刹车(水平式样) No brake (horizontal type)	200	220	ECMA-C20807ES	ASD-B20721-B

电机外置左侧/电机外置右侧
Motor external left side / Motor external right side

ML 电机外置左侧 Motor external left side

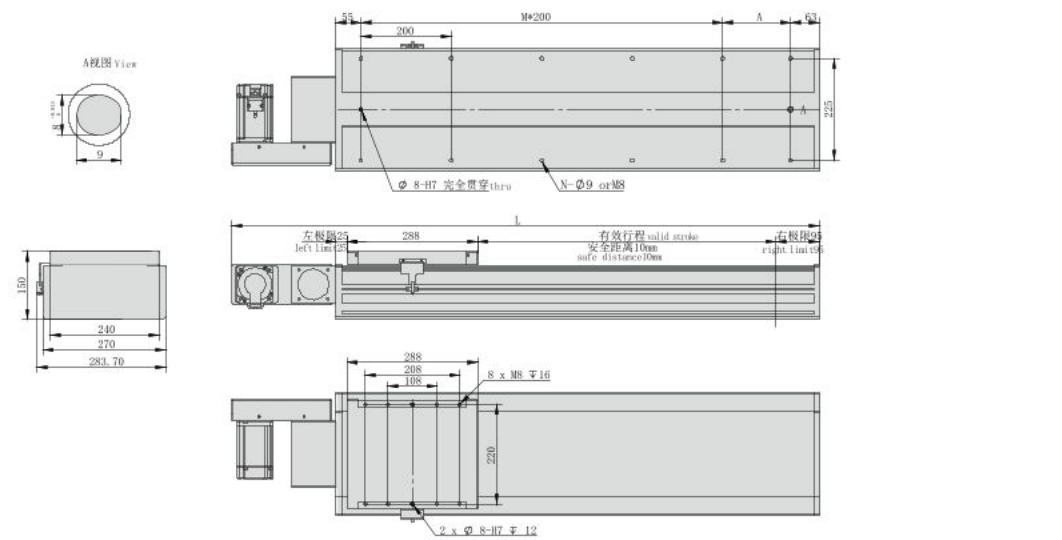

*不含电机重量。*Motor weight not included.

有效行程 Stroke	150	250	350	450	550	650	750	850	950	1050	1150	1250	1350	1450	1550	1650	1750	1850	1950	2050	2150	2250	2350	2450	2550	2650	2750	2850	2950	3050
L	798	898	998	1098	1198	1298	1398	1498	1598	1698	1798	1898	1998	2098	2198	2298	2398	2498	2598	2698	2798	2898	2998	3098	3198	3298	3398	3498	3598	3698
A	50	150	50	150	50	150	50	150	50	150	50	150	50	150	50	150	50	150	50	150	50	150	50	150	50	150	50	150	50	150
N	8	8	10	10	12	12	14	14	16	16	18	18	20	20	22	22	24	24	26	26	28	28	30	30	32	32	34	34	36	36
M	2	2	3	3	4	4	5	5	6	6	7	7	8	8	9	9	10	10	11	11	12	12	13	13	14	14	15	15	16	16
KG	32	34	36	38	40	42	44	46	48	50	52	54	56	58	60	62	64	66	68	70	72	74	76	78	80	82	84	86	88	90

如有超长行程及定制需求, 请咨询我司业务。 If you have extra long trip and custom requirements, please consult our business.

电机外置左下/电机外置左上
Motor external lower left / Motor external upper left

LP 电机外置左下 Motor external lower left

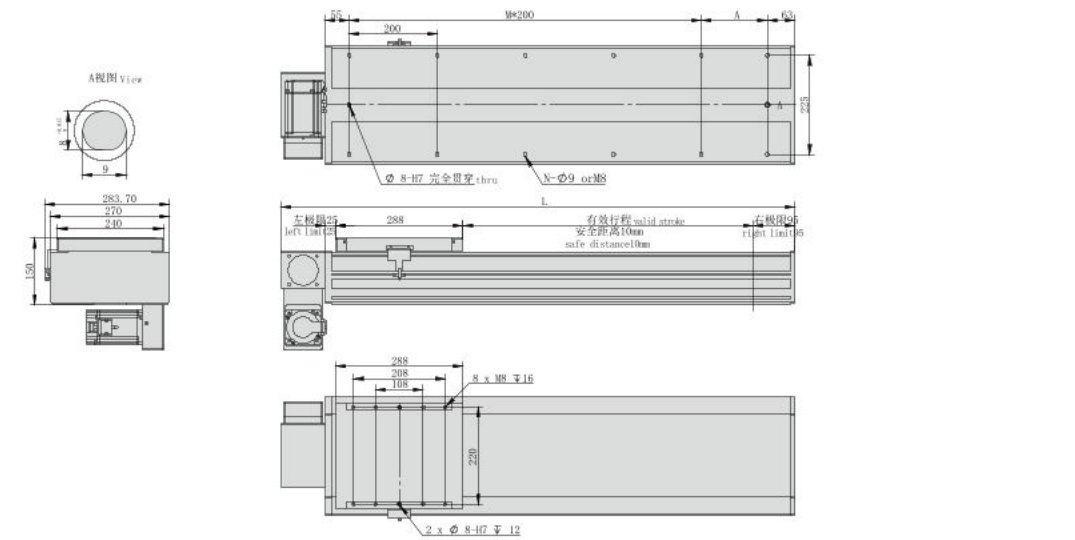

*不含电机重量。*Motor weight not included.

有效行程 Stroke	150	250	350	450	550	650	750	850	950	1050	1150	1250	1350	1450	1550	1650	1750	1850	1950	2050	2150	2250	2350	2450	2550	2650	2750	2850	2950	3050
L	668	768	868	968	1068	1168	1268	1368	1468	1568	1668	1768	1868	1968	2068	2168	2268	2368	2468	2568	2668	2768	2868	2968	3068	3168	3268	3368	3468	3568
A	50	150	50	150	50	150	50	150	50	150	50	150	50	150	50	150	50	150	50	150	50	150	50	150	50	150	50	150	50	150
N	8	8	10	10	12	12	14	14	16	16	18	18	20	20	22	22	24	24	26	26	28	28	30	30	32	32	34	34	36	36
M	2	2	3	3	4	4	5	5	6	6	7	7	8	8	9	9	10	10	11	11	12	12	13	13	14	14	15	15	16	16
KG	32	34	36	38	40	42	44	46	48	50	52	54	56	58	60	62	64	66	68	70	72	74	76	78	80	82	84	86	88	90

如有超长行程及定制需求, 请咨询我司业务。 If you have extra long trip and custom requirements, please consult our business.

电机外置右侧 Motor external right side

MR 电机外置右侧 Motor external right side

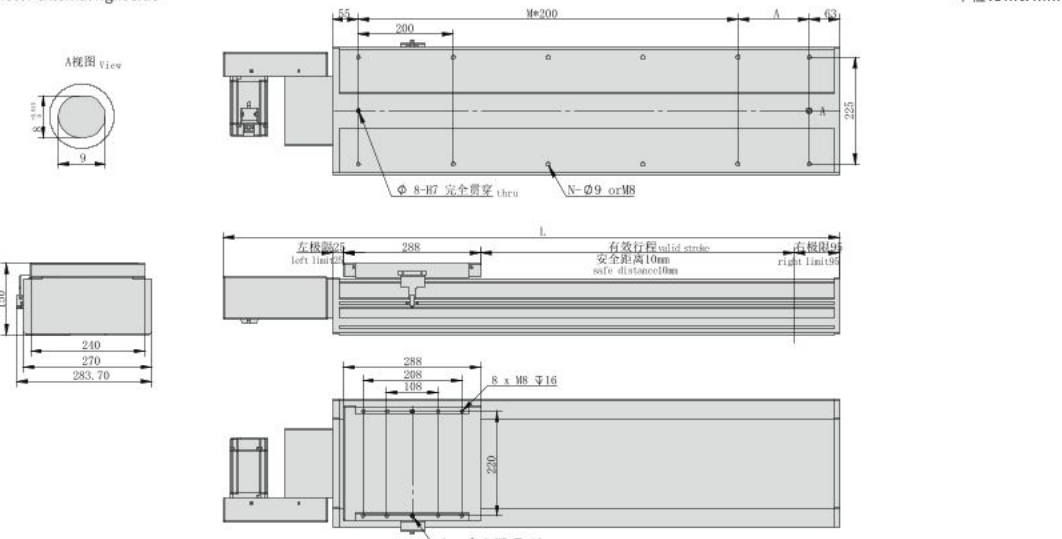

*不含电机重量。*Motor weight not included.

有效行程 Stroke	150	250	350	450	550	650	750	850	950	1050	1150	1250	1350	1450	1550	1650	1750	1850	1950	2050	2150	2250	2350	2450	2550	2650	2750	2850	2950	3050
L	798	898	998	1098	1198	1298	1398	1498	1598	1698	1798	1898	1998	2098	2198	2298	2398	2498	2598	2698	2798	2898	2998	3098	3198	3298	3398	3498	3598	3698
A	50	150	50	150	50	150	50	150	50	150	50	150	50	150	50	150	50	150	50	150	50	150	50	150	50	150	50	150	50	150
N	8	8	10	10	12	12	14	14	16	16	18	18	20	20	22	22	24	24	26	26	28	28	30	30	32	32	34	34	36	36
M	2	2	3	3	4	4	5	5	6	6	7	7	8	8	9	9	10	10	11	11	12	12	13	13	14	14	15	15	16	16
KG	32	34	36	38	40	42	44	46	48	50	52	54	56	58	60	62	64	66	68	70	72	74	76	78	80	82	84	86	88	90

如有超长行程及定制需求, 请咨询我司业务。 If you have extra long trip and custom requirements, please consult our business.

电机外置左上 Motor external upper left

LU 电机外置左上 Motor external upper left

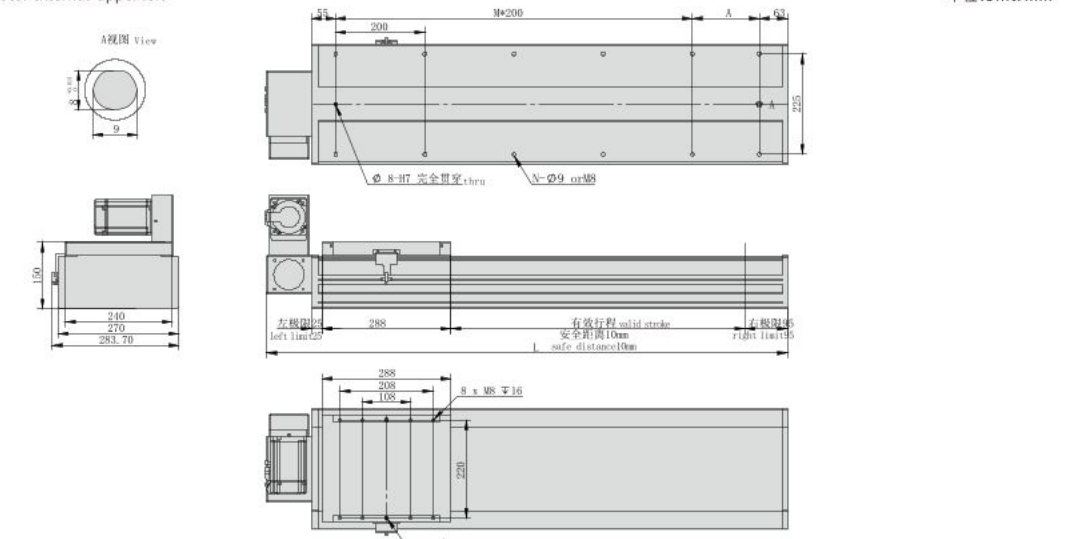

*不含电机重量。*Motor weight not included.

有效行程 Stroke	150	250	350	450	550	650	750	850	950	1050	1150	1250	1350	1450	1550	1650	1750	1850	1950	2050	2150	2250	2350	2450	2550	2650	2750	2850	2950	3050
L	668	768	868	968	1068	1168	1268	1368	1468	1568	1668	1768	1868	1968	2068	2168	2268	2368	2468	2568	2668	2768	2868	2968	3068	3168	3268	3368	3468	3568
A	50	150	50	150	50	150	50	150	50	150	50	150	50	150	50	150	50	150	50	150	50	150	50	150	50	150	50	150	50	150
N	8	8	10	10	12	12	14	14	16	16	18	18	20	20	22	22	24	24	26	26	28	28	30	30	32	32	34	34	36	36
M	2	2	3	3	4	4	5	5	6	6	7	7	8	8	9	9	10	10	11	11	12	12	13	13	14	14	15	15	16	16
KG	32	34	36	38	40	42	44	46	48	50	52	54	56	58	60	62	64	66	68	70	72	74	76	78	80	82	84	86	88	90

如有超长行程及定制需求, 请咨询我司业务。 If you have extra long trip and custom requirements, please consult our business.

- HNR
- HCR
- HNB
- HC B
- HNT
- XYZ
- ONB
- OCB
- GCR
- GCB
- GCBS
- GCRS
- ESR
- EMR
- EHR
- KSR
- LNP
- DDR

参考资料
Reference data



电机外置右下/电机外置右上
Motor external lower right / Motor external upper right

RP 电机外置右下 Motor external lower right

单位:Unit: mm

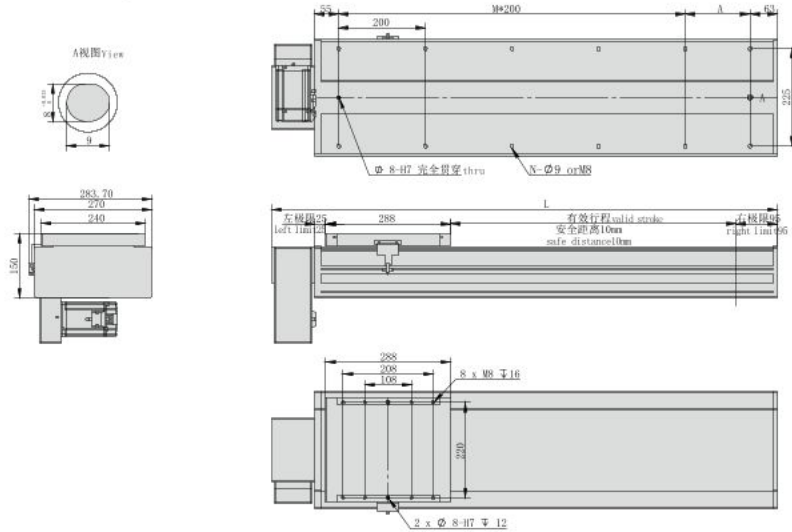

*不含电机重量。*Motor weight not included.

有效行程 Stroke	150	250	350	450	550	650	750	850	950	1050	1150	1250	1350	1450	1550	1650	1750	1850	1950	2050	2150	2250	2350	2450	2550	2650	2750	2850	2950	3050
L	668	768	868	968	1068	1168	1268	1368	1468	1568	1668	1768	1868	1968	2068	2168	2268	2368	2468	2568	2668	2768	2868	2968	3068	3168	3268	3368	3468	3568
A	50	150	50	150	50	150	50	150	50	150	50	150	50	150	50	150	50	150	50	150	50	150	50	150	50	150	50	150	50	150
N	8	8	10	10	12	12	14	14	16	16	18	18	20	20	22	22	24	24	26	26	28	28	30	30	32	32	34	34	36	36
M	2	2	3	3	4	4	5	5	6	6	7	7	8	8	9	9	10	10	11	11	12	12	13	13	14	14	15	15	16	16
KG	32	34	36	38	40	42	44	46	48	50	52	54	56	58	60	62	64	66	68	70	72	74	76	78	80	82	84	86	88	90

如有超长行程及定制需求, 请咨询我司业务。 If you have extra long trip and custom requirements, please consult our business.

RU 电机外置右上 Motor external upper right

单位:Unit: mm

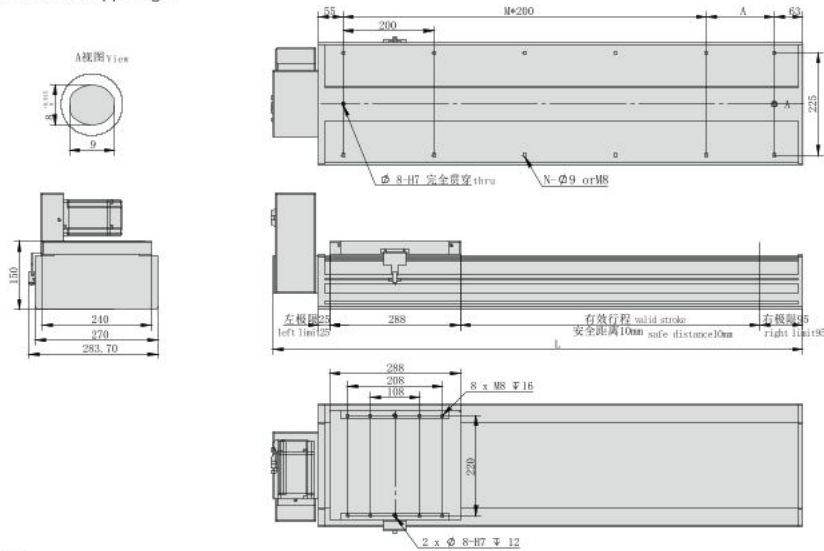

*不含电机重量。*Motor weight not included.

有效行程 Stroke	150	250	350	450	550	650	750	850	950	1050	1150	1250	1350	1450	1550	1650	1750	1850	1950	2050	2150	2250	2350	2450	2550	2650	2750	2850	2950	3050
L	668	768	868	968	1068	1168	1268	1368	1468	1568	1668	1768	1868	1968	2068	2168	2268	2368	2468	2568	2668	2768	2868	2968	3068	3168	3268	3368	3468	3568
A	50	150	50	150	50	150	50	150	50	150	50	150	50	150	50	150	50	150	50	150	50	150	50	150	50	150	50	150	50	150
N	8	8	10	10	12	12	14	14	16	16	18	18	20	20	22	22	24	24	26	26	28	28	30	30	32	32	34	34	36	36
M	2	2	3	3	4	4	5	5	6	6	7	7	8	8	9	9	10	10	11	11	12	12	13	13	14	14	15	15	16	16
KG	32	34	36	38	40	42	44	46	48	50	52	54	56	58	60	62	64	66	68	70	72	74	76	78	80	82	84	86	88	90

如有超长行程及定制需求, 请咨询我司业务。 If you have extra long trip and custom requirements, please consult our business.

MEMO

- HNR
- HCR
- HNB
- HC B
- HNT
- XYZ
- ONB
- OCB
- GCR
- GCB
- GCBS
- GCRS
- ESR
- EMR
- EHR
- KSR
- LNP
- DDR
- 参考资料
Reference data