

**BACK PULL OUT**

ปั๊มน้ำหอโย่ง (ชนิดดึงออกด้านหลัง)

# END SUCTION CENTRIFUGAL PUMP



 **KRW3 NF2**

APPLICATIONS

การใช้งาน

Single-stage volute casing are preferably used in the field of water supply. Standardized connecting dimensions allow for trouble free installation even in existing systems. Our volute casing pumps suitable for use on various applications, such as:

ปั๊มหอยโขงชนิดใบพัดเดี่ยวเหมาะสำหรับงานส่งน้ำที่หลากหลายทั่วไป มีโครงสร้างเป็นมาตรฐาน ช่วยในการติดตั้งสะดวก รวดเร็ว ถึงแม้จะติดตั้งทดแทนที่ปั๊มเดิมในเนื้อที่เดิม ก็สามารถทำได้ทันที ปั๊มชนิดนี้เหมาะสำหรับงานต่าง ๆ ดังนี้

- \* Water supply in Buildings งานส่งน้ำในตึกสูง
- \* Water Pressure Boosting งานเพิ่มแรงดันน้ำ
- \* Industrial use งานอุตสาหกรรม
- \* Drainage งานส่งน้ำต่าง ๆ
- \* Water Treatment งานบำบัดน้ำ
- \* Water Circulating งานหมุนเวียนน้ำ
- \* Irrigation งานชลประทาน
- \* Agriculture งานเกษตรกรรม
- \* Fire Protection งานป้มน้ำดับเพลิง
- \* Air Conditioning งานระบบปรับอากาศ



Power: 0.37 – 300 kW

DESIGNATION / การระบุตัวเครื่อง

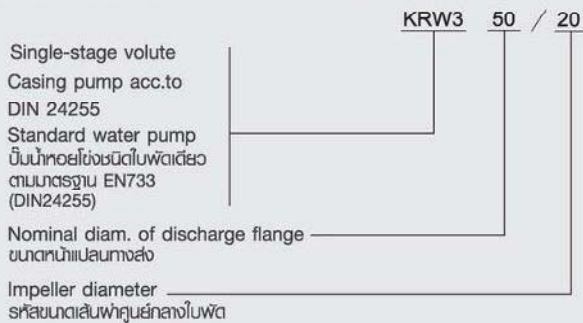

OPERATING DATA / ข้อมูลการปฏิบัติงาน

Standard	: EN733/DIN24255
Discharge Size	: DN 32 – DN300
Flow rate	: Max. 1,800 m <sup>3</sup> /hr*
Total head	: Max. 160 m.
Speed	: Max. 3,600 rpm
Max. Operating temp.	: Max. 105 °C
Max. Working pressure	: Max. 16 bar
Sealing	: Gland packing & Mechanical seal are available.

\* For higher capacity, consult factory

\*\* Material : Cast Iron (Option: Stainless Steel and Bronze are available.)

Material of Construction

วัสดุต่าง ๆ ในการผลิตปั๊ม

	Option 1	Option 2	Option 3	Option 4
Casing	Cast iron	Cast iron	Cast iron	Stainless Steel
Impeller	Cast iron	Bronze	Stainless Steel	Stainless Steel
Wear Ring	Cast iron	Cast iron	Cast iron	Stainless Steel
Shaft	Stainless Steel	Stainless Steel	Stainless Steel	Stainless Steel
Shaft Nut	Stainless Steel	Stainless Steel	Cast iron	Stainless Steel
Shaft Sleeve	Stainless Steel	Stainless Steel	Stainless Steel	Stainless Steel
Lantern Ring	Cast iron	Cast iron	Cast iron	Stainless Steel
Gland	Cast iron	Cast iron	Cast iron	Stainless Steel

Material Specification

มาตรฐาน ของวัสดุต่าง ๆ

Material	Nearest Equivalent Standard			
	Australian	British	American	DIN
Cast iron	AS1830/T200	BS 1452: GR 220	ASTM A48 CLASS 30	DIN 1691 GG 20
Bronze	AS1565/B36B	BS 1400: LG2	ASTM B584 C836	DIN 1705 G-CuSn-52nPb
Stainless Steel	AS1444 GR 403	BS 970: 403/S17	AISI-403	DIN 17440 X15Cr13(1.4024

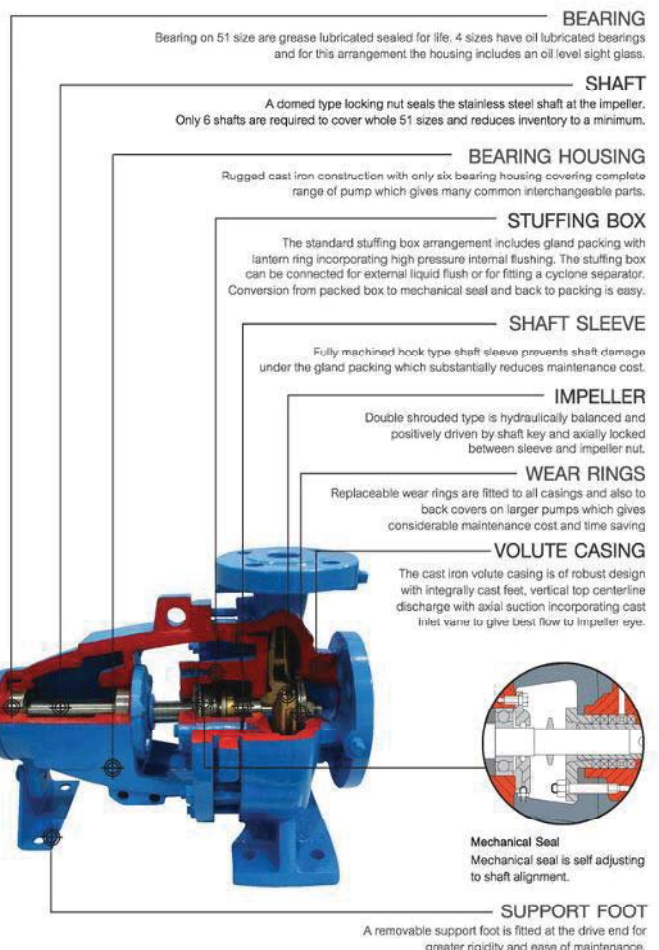

PERFORMANCE CHART 50Hz : แผนภูมิการทำงานของปั๊ม 50 Hz

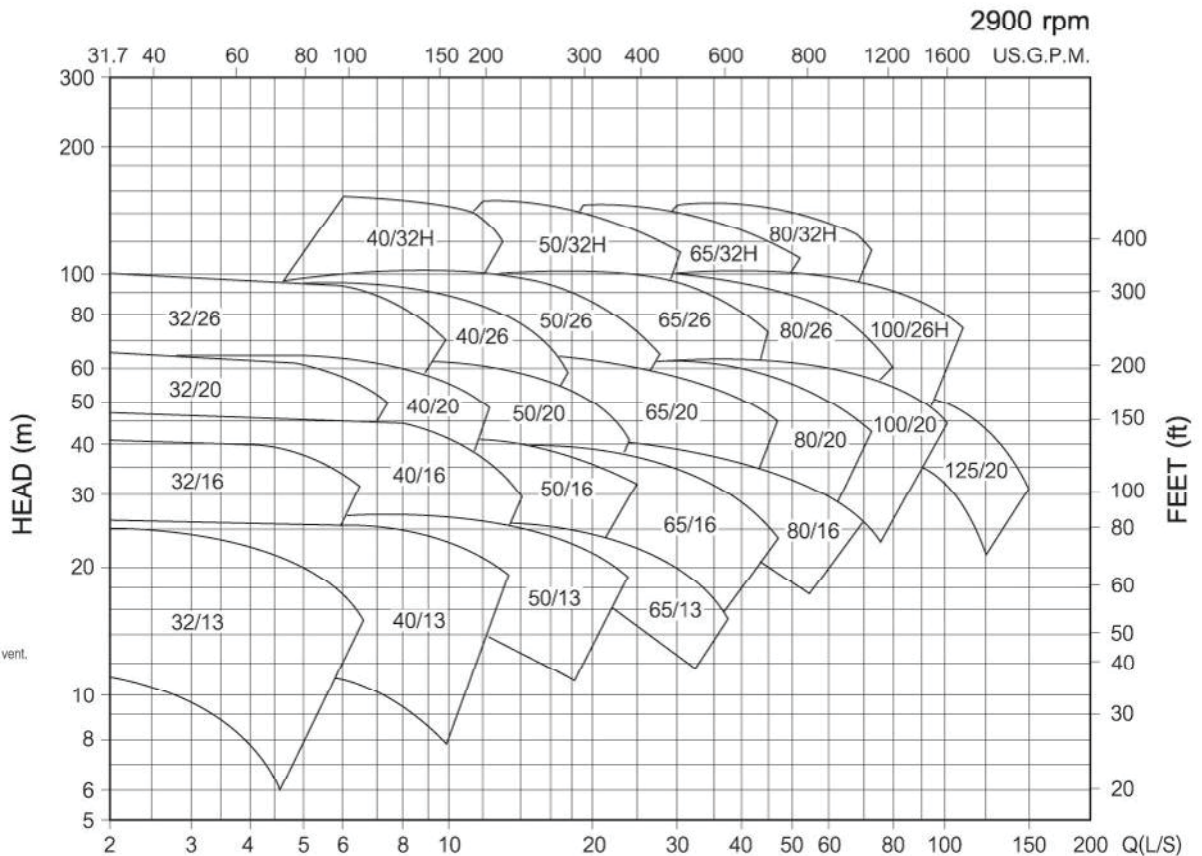
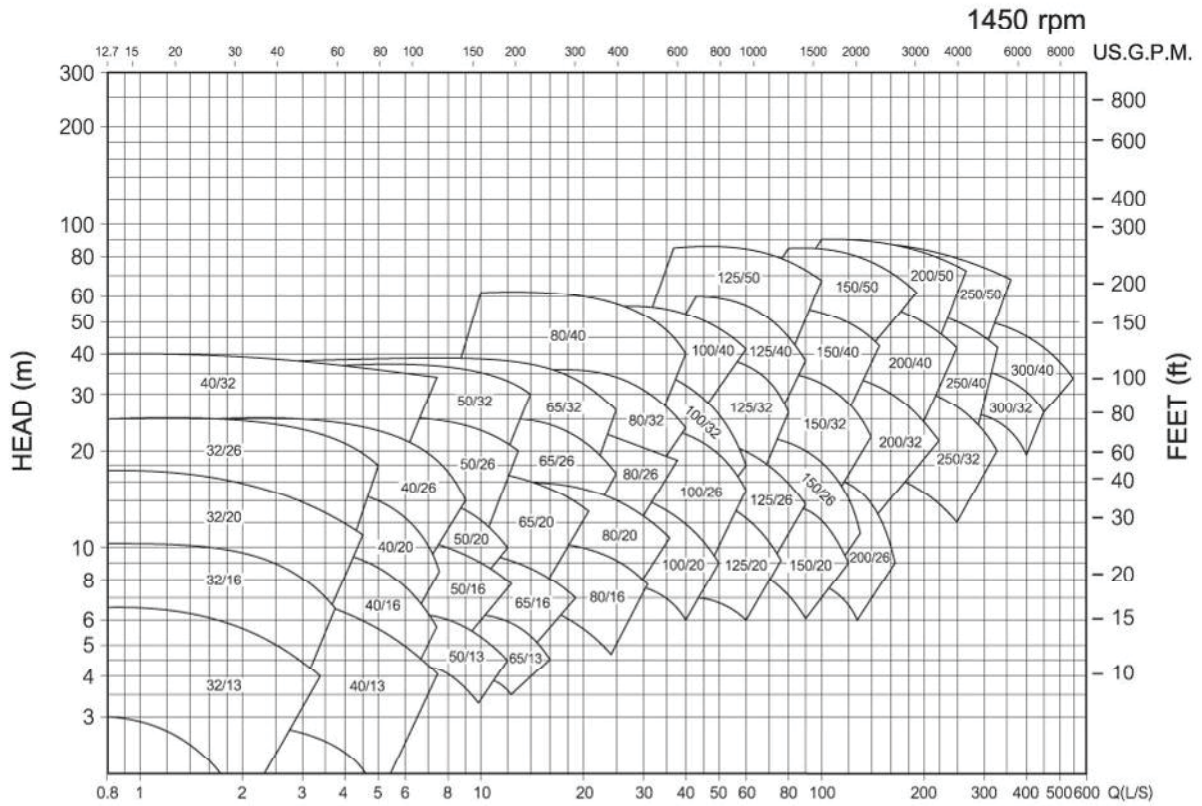

## APPLICATIONS

## การใช้งาน

แรงม้าสูงสุดสำหรับน้ำสะอาดที่มีความถ่วงจำเพาะ 1.0

โดยแรงม้าบางรุ่นอาจจะระบุกำลังแรงม้าสูงเพื่อใ้ค่าความปลอดภัยสูงกว่าปกติ 13% - 40%

The non-overloading power required when handing fresh water SG 1.0 for pumps : Some model(s) are overestimated with the power up to 13%-40% service factor.

MODEL NO.	1450RPM	2900RPM
32/13	0.37 KW	2.2 KW
32/16	0.55 KW	4.0 KW
32/20	1.1 KW	7.5 KW
32/26	2.2 KW	18.5 KW
40/13	0.55 KW	4.0 KW
40/16	1.1 KW	5.5 KW
40/20	1.5 KW	11 KW
40/26	3.0 KW	22 KW
40/32	5.5 KW	-
40/32 (H)	-	37 KW
50/13	1.1 KW	7.5 KW
50/16	1.5 KW	11 KW
50/20	2.2 KW	18.5 KW
50/26	4.0 KW	37 KW
50/32	11 KW	-
50/32 (H)	-	75 KW
65/13	1.5 KW	11 KW
65/16	2.2 KW	18.5 KW
65/20	4.0 KW	30 KW
65/26	7.5 KW	55 KW
65/32	15 KW	-
65/32 (H)	-	90 KW

MODEL NO.	1450RPM	2900RPM
80/16	4.0 KW	30 KW
80/20	7.5 KW	45 KW
80/26	11 KW	75 KW
80/32	18.5 KW	-
80/32 (H)	-	125 KW
80/40	30 KW	-
100/20	7.5 KW	55 KW
100/26	15 KW	-
100/26 (H)	-	110 KW
100/32	18.5 KW	-
100/40	37 KW	-
125/20	11 KW	75 KW
125/26	22 KW	-
125/32	30 KW	-
125/40	55 KW	-
125/50	110 KW	-
150/20	18.5 KW	-
150/26	30 KW	-
150/32	55 KW	-
150/40	90 KW	-
150/50	160 KW	-
200/26	30 KW	-
200/32	60 KW	-
200/40	150 KW	-
200/50	250 KW	-
250/32	90 KW	-
250/40	160 KW	-
250/50	300 KW	-
300/40	250 KW	-

## PART LIST

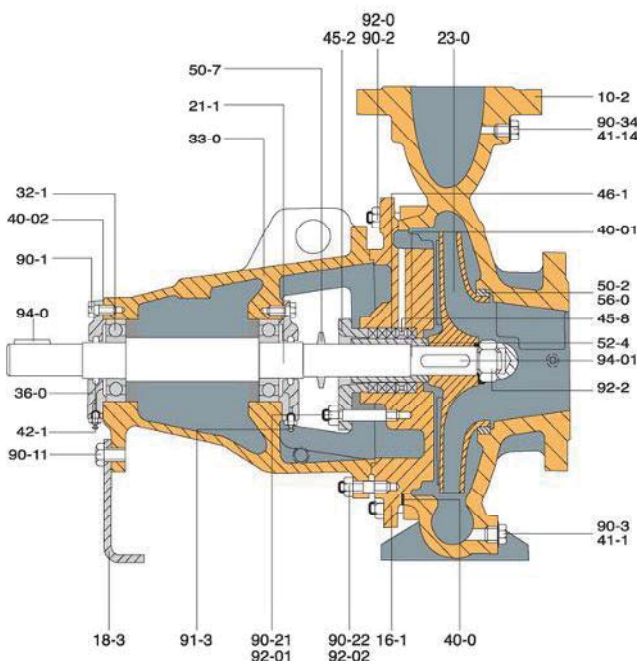

PART NO.	DESCRIPTION	QTY.
10-2	Pump Casing	1
50-2	Case Wear Ring	1
56-0	Dowel	2
40-0	Casing Gasket	1
90-3	Drain Plug	1
41-1	Gasket Ring	1
91-3	Grease Nipple	2
23-0	Impeller	1
90-2	Stud-Casing	8/12
92-0	Nut-Casing	8/12
18-3	Support Foot	1
90-34	Gauge Plug	1
41-14	Gasket Ring	1
90-11	Hex. Screw	1
16-1	Casing Back Cover	1
45-8	Lantern Ring	1
45-2	Gland	1
46-1	Gland Packing	4
52-4	Shaft Sleeve	1
40-01	Sleeve Gasket	1
90-22	Stud-Back Cover	8/6
92-02	Nut-Back Cover	8/6
90-21	Stud-Gland	2
92-01	Nut-Gland Stud	2
33-0	Bearing Housing	1
36-0	Bearing Cover	2
40-02	Gasket	2
42-1	Oil Seal	2
32-1	Bearing	2
21-1	Shaft	1
94-0	Coupling Key	1
94-01	Impeller Key	1
92-2	Impeller Nut	1
50-7	Thrower	1
90-1	Hex. Screw	6

## OUTLINE & DIMENSIONS : ขนาดรูปทรงมิติ

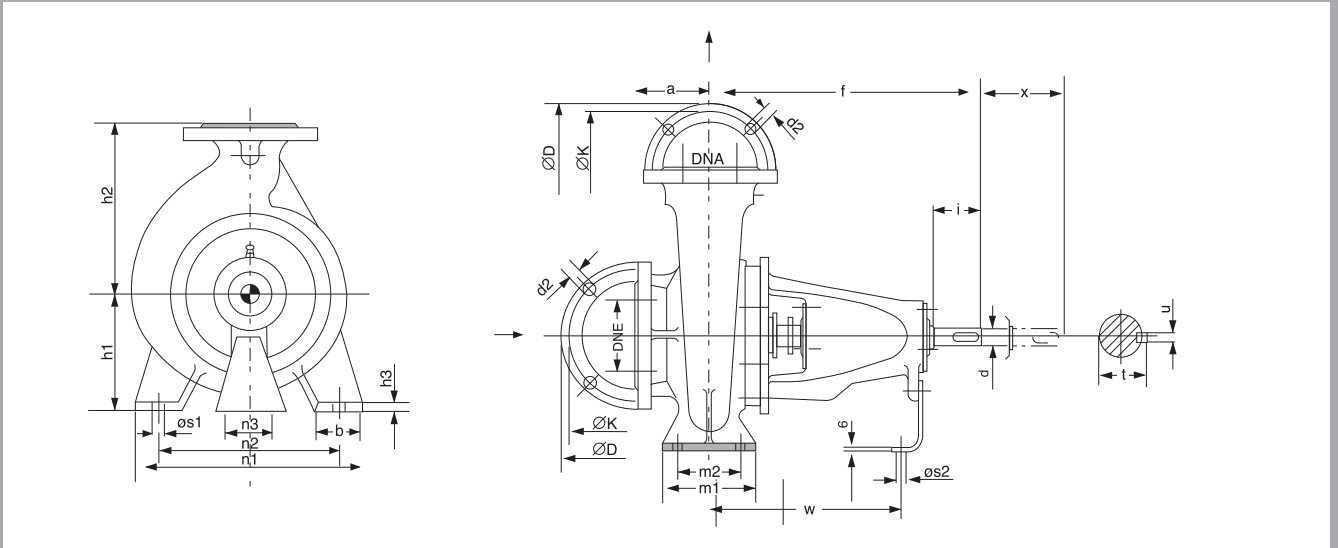

### DIMENSIONS : มิติ

Pump size	Shaft unit	DNE	DNA	a	f	h1	h2	b	m1	m2	n1	n2	n3	h3	os1	os2	w	d	l	t	u	WT kg
32/13	25	Ø50	Ø32	80	360	112	140	50	100	70	190	140	100	14	14	14	267	24	50	27	8	27.5
32/16	25	Ø50	Ø32	80	360	132	160	50	100	70	240	190	100	14	14	14	267	24	50	27	8	35
32/20	25	Ø50	Ø32	80	360	160	180	50	100	70	240	190	110	14	14	14	267	24	50	27	8	41
32/26	25	Ø50	Ø32	100	360	180	225	65	125	95	320	250	110	14	14	14	267	24	50	27	8	59
40/13	25	Ø65	Ø40	80	360	112	140	50	100	70	210	160	100	14	14	14	267	24	50	27	8	30
40/16	25	Ø65	Ø40	80	360	132	160	50	100	70	240	190	100	14	14	14	267	24	50	27	8	36
40/20	25	Ø65	Ø40	100	360	160	180	50	100	70	265	212	110	14	14	14	267	24	50	27	8	44
40/26	25	Ø65	Ø40	100	360	180	225	65	125	95	320	250	110	14	14	14	267	24	50	27	8	61
40/32	35	Ø65	Ø40	125	470	200	225	65	125	95	345	280	110	14	14	14	342	32	80	35	10	45.8
40/32H	35	Ø65	Ø40	125	518	200	225	65	133	95	351	280	110	14	14	14	372	42	108	45	12	45.8
50/13	25	Ø65	Ø50	100	360	132	160	50	100	70	240	190	100	14	14	14	267	24	50	27	8	34
50/16	25	Ø65	Ø50	100	360	160	180	50	100	70	265	212	110	14	14	14	267	24	50	27	8	38
50/20	25	Ø65	Ø50	100	360	160	200	50	100	70	265	212	110	14	14	14	267	24	50	27	8	46
50/26	25	Ø65	Ø50	100	360	180	225	65	125	95	320	250	110	14	14	14	267	24	50	27	8	63
50/32	35	Ø65	Ø50	125	470	225	280	65	125	95	345	280	110	16	14	14	342	32	80	35	10	101
50/32H	35	Ø65	Ø50	125	518	225	280	65	133	95	370	280	110	16	14	14	372	42	108	45	12	101
65/13	25	Ø80	Ø65	100	360	160	180	65	125	95	280	212	110	14	14	14	267	24	50	27	8	39
65/16	25	Ø80	Ø65	100	360	160	200	65	125	95	280	212	110	14	14	14	267	24	50	27	8	43
65/20	25	Ø80	Ø65	100	360	180	225	65	125	95	320	250	110	14	14	14	267	24	50	27	8	70
65/26	35	Ø80	Ø65	100	470	200	250	80	160	120	360	280	110	16	17.5	14	342	32	80	35	10	91
65/32	35	Ø80	Ø65	125	470	225	280	80	160	120	400	315	110	16	17.5	14	342	32	80	35	10	110
65/32H	35	Ø80	Ø65	125	518	225	280	80	164	120	400	315	110	16	17.5	14	360	42	108	45	12	110
80/16	25	Ø100	Ø80	125	360	180	225	65	125	95	320	250	110	14	14	14	267	24	50	27	8	54
80/20	35	Ø100	Ø80	125	470	180	250	65	125	95	345	280	110	14	14	14	342	32	80	35	10	70
80/26	35	Ø100	Ø80	125	470	200	280	80	160	120	400	315	110	16	17.5	14	342	32	80	35	10	91
80/32	35	Ø100	Ø80	125	470	250	315	80	160	120	400	315	110	16	17.5	14	342	32	80	35	10	120
80/32H	35	Ø100	Ø80	125	518	250	315	90	170	120	400	315	110	16	17.5	14	355	42	108	45	12	120
80/40	45	Ø100	Ø80	125	530	280	355	85	160	120	440	340	110	16	17.5	14	368	42	110	45	12	161
100/20	35	Ø125	Ø100	125	470	200	280	80	160	120	360	280	110	16	17.5	14	342	32	80	35	10	85
100/26	35	Ø125	Ø100	140	470	225	280	80	160	120	400	315	110	16	17.5	14	342	32	80	35	10	106
100/26H	35	Ø125	Ø100	140	530	225	280	80	170	120	400	315	110	16	17.5	14	372	42	108	45	12	143
100/32	35	Ø125	Ø100	140	470	250	315	80	160	120	400	315	100	16	17.5	14	342	32	80	35	10	134
100/40	45	Ø125	Ø100	140	530	280	355	100	200	150	500	400	110	18	23	14	370	42	110	45	12	174
125/20	35	Ø150	Ø125	140	470	250	315	80	160	120	400	315	110	16	17.5	14	342	32	80	35	10	106
125/26	35	Ø150	Ø125	140	470	250	355	80	160	120	400	315	110	16	17.5	14	342	32	80	35	10	115
125/32	45	Ø150	Ø125	140	530	280	355	100	200	150	500	400	110	18	23	14	370	42	110	45	12	163
125/40	45	Ø150	Ø125	140	530	315	400	100	200	150	500	400	110	18	23	14	370	42	110	45	12	181
125/50	60	Ø150	Ø125	180	680	375	500	100	200	150	550	450	140	24	24	14	500	55	110	59	16	220
150/20	35	Ø200	Ø150	160	495	280	400	100	200	150	550	450	110	20	23	14	367	32	80	35	10	156
150/26	45	Ø200	Ø150	160	530	250	355	100	200	150	450	350	110	18	23	14	370	42	110	45	12	148
150/32	45	Ø200	Ø150	160	530	280	400	100	200	150	550	450	110	18	23	14	370	42	110	45	12	170
150/40	45	Ø200	Ø150	160	530	315	450	100	200	150	550	450	110	18	23	14	370	42	110	45	12	209
150/50	60	Ø200	Ø150	180	670	375	500	100	200	150	550	450	140	24	24	15	500	55	110	59	16	430
200/26	45	Ø250	Ø200	180	546	280	400	100	200	150	550	450	110	25	26	15	389	42	110	45	12	210
200/32	55	Ø250	Ø200	200	670	355	450	100	200	150	550	450	110	20	24	15	500	48	110	52	14	323
200/40	55	Ø250	Ø200	200	670	355	500	100	200	150	550	450	110	20	24	15	500	48	110	52	14	370
200/50	60	Ø250	Ø200	210	783	425	545	160	300	240	720	600	140	30	27	23	534	55	110	59	16	530
250/32	55	Ø300	Ø250	200	783	425	545	160	300	240	720	600	140	30	27	23	534	48	110	52	14	370
250/40	60	Ø300	Ø250	240	783	425	545	160	300	240	720	600	140	30	27	23	534	55	110	59	16	457
250/50	75	Ø300	Ø250	240	783	425	545	160	300	240	720	600	140	30	27	23	534	70	140	75	20	646
300/40	75	Ø350	Ø300	280	783	500	600	150	300	200	800	660	140	40	27	23	550	70	140	75	20	720

### Flange mating dimensions to ISO 2084 PN16

DN <sub>w</sub> /DN <sub>e</sub>	32	40	50	65	80	100	125	150	200	250	300	350
ØD	140	150	165	185	200	220	250	285	340	405	460	520
ØK	100	110	125	145	160	180	210	240	295	355	410	470
d x number	18x4	18x4	18x4	18x4	18x8	18x8	18x8	22x8	22x12	26x12	26x12	26x16



**SAHAKIM MOTOR CO., LTD.**

46-52 Chalermketh 3Rd., Wat Thepsirin, Pomprab, Bangkok 10100, Thailand.  
Tel: 02 621 5761-8 | Fax: 02 621 5770

End Suction Pump/KRW3  
February Issue1 (2017)

[www.sahakimmotor.co.th](http://www.sahakimmotor.co.th)