

Cloud capable and communicating Non Fail-Safe damper actuator for controlling dampers in typical commercial HVAC applications.

- Torque motor 10 Nm
- Nominal voltage AC/DC 24 V
- Control modulating, communicative, Hybrid, Cloud
- Conversion of sensor signals
- Ethernet 10/100 Mbit/s, TCP/IP, integrated web server
- Communication via BACnet IP, Modbus TCP and Cloud



5-year warranty



Technical data

Electrical data	Nominal voltage	AC/DC 24 V
	Nominal voltage frequency	50/60 Hz
	Nominal voltage range	AC 19.2...28.8 V / DC 21.6...28.8 V
	Power consumption in operation	4.5 W
	Power consumption in rest position	3 W
	Transformer sizing	6 VA
	Parallel operation	Yes (note the performance data)
	Electrical Connection	18 GA appliance cable, 1/2" conduit connector and RJ45 socket (ethernet)
	Overload Protection	electronic throughout 0...95° rotation
Data bus communication	Communicative control	Cloud BACnet IP Modbus TCP
	Number of nodes	BACnet / Modbus see interface description
Functional data	Torque motor	10 Nm
	Operating range Y	2...10 V
	Operating range Y note	Hybrid via 2...10 V
	Input impedance	34 kΩ
	Operating range Y variable	0.5...10 V
	Position feedback U	2...10 V
	Position feedback U note	Max. 0.5 mA
	Position feedback U variable	VDC variable
	Position accuracy	±5%
	Direction of motion motor	selectable with switch 0/1
	Manual override	external push button
	Angle of rotation	95°
	Angle of rotation note	adjustable with mechanical stop
	Running Time (Motor)	150 s / 90°
	Running time motor variable	70...220 s
	Adaptation Setting Range	manual
Noise level, motor	45 dB(A)	
Position indication	Mechanical, pluggable	
Safety data	Protection class IEC/EN	III, Safety Extra-Low Voltage (SELV)
	Power source UL	Class 2 Supply

Safety data	Degree of protection IEC/EN	IP54 IP54 when using protective cap or protective grommet for RJ45 socket	
	Degree of protection NEMA/UL	NEMA 1	
	Enclosure	UL Enclosure Type 1	
	EMC	CE according to 2014/30/EU	
	Agency Listing	cULus acc. to UL60730-1A/-2-14, CAN/CSA E60730-1:02 CE acc. to 2014/30/EU and 2014/35/EU	
	Quality Standard	ISO 9001	
	UL 2043 Compliant	Suitable for use in air plenums per Section 300.22(C) of the NEC and Section 602 of the IMC	
	Type of action	Type 1	
	Ambient humidity	Max. 95% RH, non-condensing	
	Ambient temperature	-22...122°F [-30...50°C]	
	Storage temperature	-40...176°F [-40...80°C]	
	Servicing	maintenance-free	
	Weight	Weight	1.5 lb [0.68 kg]
	Materials	Housing material	UL94-5VA

Safety notes



- The device must not be used outside the specified field of application, especially not in aircraft or in any other airborne means of transport.
- Outdoor application: only possible in case that no (sea) water, snow, ice, insulation or aggressive gases interfere directly with the actuator and that is ensured that the ambient conditions remain at any time within the thresholds according to the data sheet.
- Only authorized specialists may carry out installation. All applicable legal or institutional installation regulations must be complied during installation.
- The device may only be opened at the manufacturer's site. It does not contain any parts that can be replaced or repaired by the user.
- Cables must not be removed from the device.
- To calculate the torque required, the specifications supplied by the damper manufacturers concerning the cross-section, the design, the installation situation and the ventilation conditions must be observed.
- The device contains electrical and electronic components and must not be disposed of as household refuse. All locally valid regulations and requirements must be observed.

Product features

Mode of operation	The actuator is controlled via the Cloud, BACnet IP or Modbus TCP and drives to the position defined by the control signal. Various data points can be written and read via the same interfaces. Hybrid mode: The actuator receives its analog control signal from the higher level controller and drives to the position defined. Using the Cloud, BACnet IP or Modbus TCP, various data points can be read and with the exception of the control signal written.
Converter for sensors	Connection option for two sensors (passive sensor, active sensor or switching contact). The actuator serves as an analog/digital converter for the transmission of the sensor signal to the higher level system.

Communication The configuration can be carried out through the integrated web server (RJ45 connection to the web browser), by communicative means or via the Cloud.
Additional information regarding the integrated web server can be found in the separate documentation.

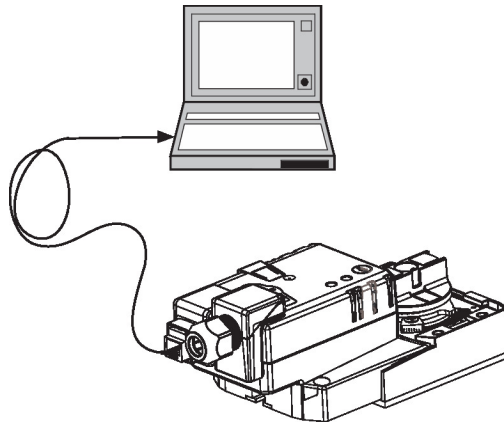
"Peer to Peer" connection
<http://belimo.local:8080>
 The Notebook must be set to "DHCP".
 Make sure that only one network connection is active.
Standard IP address:
<http://192.168.0.10:8080>
 Static IP address
Password (read-only):
 User name: «guest»
 Password: «guest»



Control signal inversion This can be inverted in cases of control with an analogue control signal. The inversion causes the reversal of the standard behavior, i.e. for control signal 0%, the actuator is opened to max and for control signal 100%, the actuator is closed.

Simple direct mounting Simple direct mounting on the damper shaft with a universal shaft clamp, supplied with an anti-rotation device to prevent the actuator from revolving.

Data recording The recorded data (integrated data recording for 13 months) can be used for analytical purposes.
Download csv files via web browser.

Manual override Manual override with push-button possible (the gear train is disengaged for as long as the button is pressed or remains locked).

Adjustable angle of rotation Adjustable angle of rotation with mechanical end stops.

High functional reliability The actuator is overload protected, requires no limit switches and automatically stops when the end stop is reached.

Home position The first time the supply voltage is switched on, i.e. at the time of commissioning, the actuator carries out an adaptation, which is when the operating range and position feedback adjust themselves to the mechanical setting range.
The actuator then moves into the position defined by the control signal.

Adaptation and synchronisation An adaptation can be triggered manually by pressing the "Adaptation" button. Both mechanical end stops are detected during the adaptation (entire setting range).
The actuator then moves into the position defined by the control signal.

Accessories

Electrical accessories	Description	Type
	Battery backup system, for non-spring return models	NSV24 US
	Battery, 12 V, 1.2 Ah (two required)	NSV-BAT

Mechanical accessories	Description	Type
	Damper crank arm Slot width 6.2 mm, clamping range \varnothing 10...18 mm	KH6
	Damper crank arm Slot width 8.2 mm, clamping range \varnothing 10...18 mm	KH8
	Damper crank arm Slot width 8.2 mm, clamping range \varnothing 14...25 mm	KH10
	Damper crank arm Slot width 8.2 mm, for \varnothing 1.05"	KH12
	Ball joint suitable for damper crank arm KH8, Multipack 10 pcs.	KG6
	Ball joint suitable for damper crank arm KH8, Multipack 10 pcs.	KG8
	Ball joint suitable for damper crank arm KH8 / KH10, Multipack 10 pcs.	KG10A
	Push rod for KG6 & KG8 ball joints (36" L, 5/16" diameter).	SH8
	Push rod for KG10A ball joint 36" L, 3/8" diameter	SH10
	Damper clip for damper blade, 3.5" width.	ZG-DC1
	Damper clip for damper blade, 6" width.	ZG-DC2
	Weather shield 13x8x6" [330x203x152 mm] (LxWxH)	ZS-100
	Base plate, for ZS-100	ZS-101
	Weather shield 406x213x102 mm [16x8-3/8x4"] (LxWxH)	ZS-150
	Shaft extension 240 mm \varnothing 20 mm for damper shaft \varnothing 8...22.7 mm	AV8-25
	Anti-rotation bracket TF/NKQ/AM/NM/LM.	TF-P
	Mounting bracket for AF..	ZG-100
	Mounting bracket	ZG-101
	Wrench 0.32 in and 0.39 in [8 mm and 10 mm]	TOOL-06
	Adapter for auxiliary switch and feedback potentiometer	Z-SPA
	Shaft extension 170 mm \varnothing 10 mm for damper shaft \varnothing 6...16 mm	AV6-20
	Clamp NM/AM 1/2", 3/4", 1"	K-AM25
	Shaft clamp reversible, clamping range \varnothing 8...20 mm	K-NA
	Mounting bracket	ZG-109
	Linkage kit	ZG-110
	Jackshaft mounting bracket.	ZG-120
	Shaft extension for 1/2" diameter shafts (3.8" L).	ZG-NMSA-1
	Mounting plate for SGF.	ZG-SGF
	1" diameter jackshaft adaptor (11" L).	ZG-JSA-1
	1-5/16" diameter jackshaft adaptor (12" L).	ZG-JSA-2
	1.05" diameter jackshaft adaptor (12" L).	ZG-JSA-3
	Mounting kit for linkage operation for flat installation	ZG-NMA
	Linkage kit	ZG-JSL
	Jackshaft Retrofit Linkage with Belimo Rotary Actuators	
	Explosion proof housing 16x10x6.435" [406x254x164 mm] (LxWxH), UL and CSA, Class I, Zone 1&2, Groups B, C, D, (NEMA 7), Class III, Hazardous (classified) Locations	ZS-260
	Weather shield 17-1/4x8-3/4x5-1/2" [438x222x140 mm] (LxWxH), NEMA 4X, with mounting brackets	ZS-300
	Weather shield 17-1/4x8-3/4x5-1/2" [438x222x140 mm] (LxWxH), NEMA 4X, with mounting brackets	ZS-300-5
	Shaft extension 1/2"	ZS-300-C1
	Shaft extension 3/4"	ZS-300-C2
	Shaft extension 1"	ZS-300-C3
	Actuator arm for standard shaft clamp (one-sided)	AH-25
	Base plate extension for NM..A to NM..	Z-NMA
Tools	Description	Type
	Signal simulator, Power supply AC 120 V	PS-100
	Connecting cable 16 ft [5 m], A: RJ11 6/4 ZTH EU, B: 6-pin for connection to service socket	ZK1-GEN
	Connecting cable 10 ft [3 m], A: RJ11 6/4 ZTH EU, B: 3-pin Weidmüller and supply connection	ZK4-GEN
	Service Tool, with ZIP-USB function, for programmable and communicative Belimo actuators, VAV controller and HVAC performance devices	ZTH US

Electrical installation

Supply from isolating transformer.
Parallel connection of other actuators possible. Observe the performance data.

Wiring diagrams

AC/DC 24 V

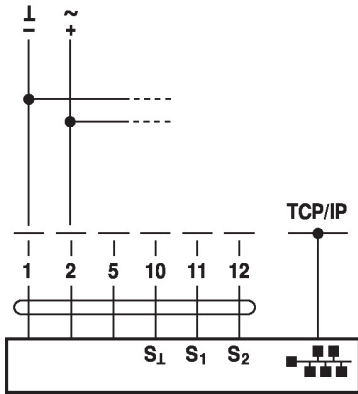

Cable colors:

- 1 = black
- 2 = red
- 5 = orange
- 10 = yellow-black
- 11 = yellow-pink
- 12 = yellow-grey

Connection of a notebook for parametrisation and manual control via RJ45.

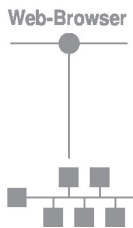

Optional connection via RJ45 (direct connection Notebook / connection via Intranet or Internet) for access to the integrated web server

Functions



The connection diagrams shows connections for the first sensor on terminal S1, while the second sensor can be connected identically on terminal S2.
 Parallel use of different sensor types is permitted.
 For hybrid operation, S1 is used for the control signal Y and must be configured as an active sensor.

Functions with specific parameters (parametrization necessary)

TCP/IP (Cloud) / BACnet IP / Modbus TCP

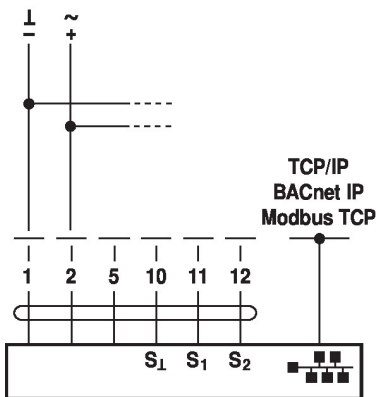

TCP/IP (Cloud) / BACnet IP / Modbus TCP with analogue setpoint (hybrid operation)

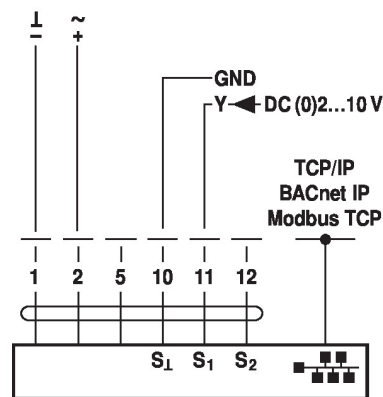

Connection of passive sensors

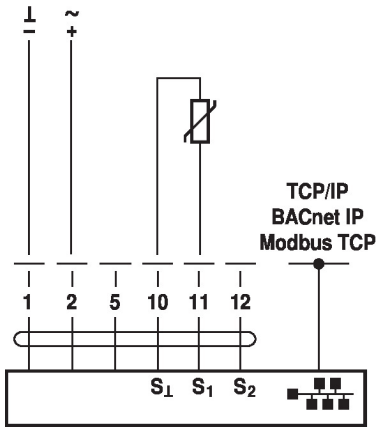

Connection of active sensors

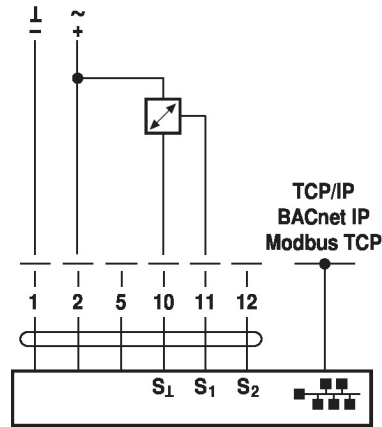

Switching contact connection

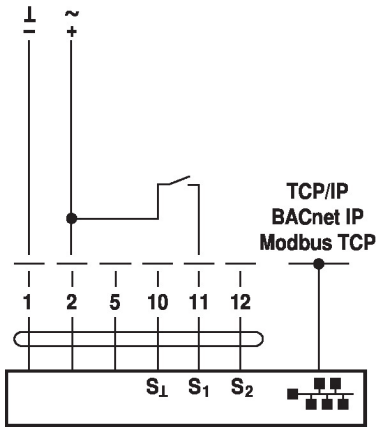

Dimensions

- ∅ 1/4" to 3/4" [6 to 20]
- 5/16" to 3/4" [8 to 26]

