

Safety Relief Valve

Product Bulletin 72-00 E

Type: SRH



Purpose:

Type **SRH High Capacity Safety Relief Valves** should be used to protect each refrigeration system pressure vessel that can be isolated by valves.

In many localities state or municipal codes govern selection and installation of Relief Valves. Many are patterned after the ASME Boiler and Pressure Vessel Code and the ANSI/ASHRAE 15 Safety Code for Mechanical Refrigeration. Where no compulsory code exist, installation of Relief Valves according to this ANSI/ASHRAE Code is highly recommended.

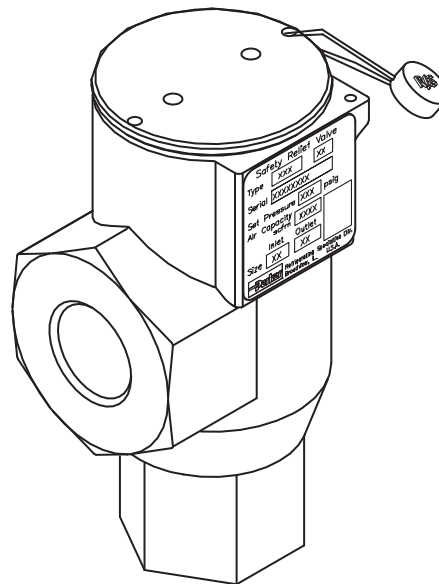

Vapor use only

Contact Information:

Parker Hannifin Corporation
Refrigerating Specialties Division
2445 South 25th Avenue
Broadview, IL 60155-3891

phone (708) 681-6300
fax (708) 681-6306

www.parker.com/refspec

Product Features:

- ANSI / ASHRAE 15 Complaint
- Excellent Repeatability
- Unaffected by Vibration
- All Stainless Steel Internal Parts
- PTFE Seat
- Capacity Rating for Vapor Only
- Pressure Settings 150 to 400 psi
- Suitable for Ammonia, R22, R502, R404A, R717 and other common refrigerants



ENGINEERING YOUR SUCCESS.

Description

Type SRH High Capacity Safety Relief Valves are designed and constructed to meet the requirements of Section VIII ASME Boiler and Pressure Vessel Code and ANSI/ASHRAE 15 Code requirements and bear the ASME Code Symbol (UV).

Employing proven principles of design, these Safety Relief Valves are highly reliable and dependable. Precision machined moving parts of stainless steel, and a PTFE disc prevent sticking due to corrosion or cold welding and ensure valve opening at the set pressure long after installation. They are not suitable for corrosive ambient atmospheres such as chlorine, etc.

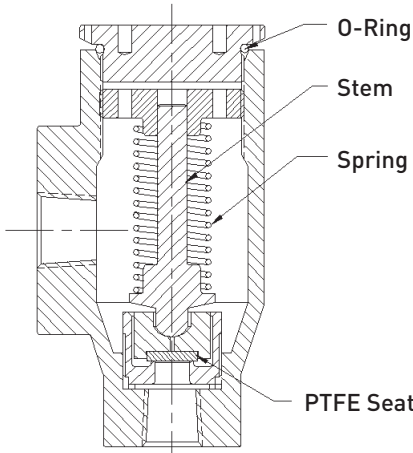

Figure 1: SRH Cross-Section

Application

The Type SRH1 through SRH5 valves are for use with Ammonia and Halocarbon refrigerants in non-corrosive environments. Pressure settings and capacities apply only when the valve is discharging to atmospheric pressure.

Pressure Settings

Codes require valve settings equal to or less than design working pressure of the vessel protected. The Type SRH Safety Relief Valves are available in six standard settings, from 150 psig to 400 psig in 50 lb. increments. Special settings between 150 psig to 400 psig in 25 lb. increments are also available. To retain the validity of the code symbols, pressure settings and capacity, these valves must be set and sealed at the factory. When required, valves can be returned to the factory for verification of setting, or readjustment to the original setting. No major repairs or reconditioning will be done. Contact factory for details.

Selection Data

The Type SRH Safety Relief Valve is intended to prevent the pressure of the vessel from rising more than 10% above the Design Working Pressure (DWP) of the vessel or the pressure setting of the relief device, whichever is the lower pressure.

Whenever conditions permit, it is advisable to have the relief valve pressure setting (which must not exceed the design working pressure of the vessel) at least 25% higher than the normal operating pressure for the refrigerant used.

Capacities

Valve Type	Relief Valve Inlet	Relief Valve Outlet	Pressure Setting psig	Lbs. Per.Min Air	SCFM Air
SRH1R	1/2" FPT	3/4" FPT	150	31	410
			200	41	535
			250	50	661
			300	60	786
			350	69	911
SRH1	1/2" FPT	3/4" FPT	400	79	1037
			150	35	463
			200	46	605
			250	57	747
			300	68	889
SRH2	1/2" FPT	1" FPT	350	79	1031
			400	89	1173
			150	35	463
			200	46	605
			250	57	747
SRH3UR	3/4" FPT	1" FPT	300	68	889
			350	79	1031
			400	89	1173
			150	10	135
			200	13	176
SRH3R	3/4" FPT	1" FPT	250	17	217
			300	20	259
			350	23	300
			400	26	341
			150	22	284
SRH3	3/4" FPT	1" FPT	200	28	371
			250	35	458
			300	41	545
			350	48	632
			400	55	718
SRH4R	1" FPT	1-1/4" FPT	150	35	463
			200	46	605
			250	57	747
			300	68	889
			350	79	1031
SRH4	1" FPT	1-1/4" FPT	400	89	1173
			150	27	359
			200	36	469
			250	44	579
			300	52	689
SRH5	1-1/4" FPT	1-1/2" FPT	350	61	799
			400	69	909
			150	61	798
			200	79	1042
			250	100	1311
SRH5	1-1/4" FPT	1-1/2" FPT	300	117	1530
			350	135	1775
			400	-	-
			150	73	963
			200	96	1258
SRH5	1-1/4" FPT	1-1/2" FPT	250	118	1553
			300	141	1848
			350	163	2142
			400	-	-

Dimensional Information

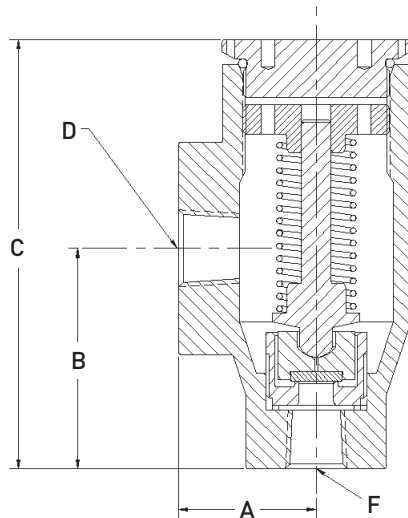

Dimensions: Inches (mm)

Valve	A	B	C	D	F
SRH1	1.562 (40)	2.75 (70)	5.05 (128)	3/4" NPT	1/2" NPT
SRH1R					
SRH2	1.562 (40)	2.75 (70)	5.05 (128)	1" NPT	3/4" NPT
SRH3					
SRH3UR					
SRH4	2.25 (57)	4.11 (104)	7.4 (188)	1-1/4" NPT	1" NPT
SRH4R					
SRH5				1-1/2" NPT	1-1/4" NPT

Figure 2: SRH Dimensional Cross-Section

Pressure limiting devices, such as high pressure cut-outs on positive displacement compressor systems, must stop the action of the pressure imposing element at no higher than 90% of the pressure setting for the pressure relief device.

For non-positive displacement compressors, the pressure limiting device, such as a high pressure cut-out, may be set at the DWP of the high side; providing, the low side is protected by a properly sized pressure relief device set to relieve pressure at low side DWP and there are no stop valves in the system that isolate the high side from the low side.

Discharge piping from relief devices must not exceed specified lengths indicated in ANSI/ASHRAE 15 with discharge to atmosphere.

In order to calculate the minimum required discharge capacity of a relief device, please reference IIAR 2 for R717 or ANSI/ASHRAE 15 for all other refrigerants.

Safe Operation (See Bulletin RSBCV)

People doing any work on a refrigeration system must be qualified and completely familiar with the system and the Refrigerating Specialties Division valves involved, or all other precautions will be meaningless. This includes reading and understanding pertinent Refrigerating Specialties Division Product Bulletins and Safety Bulletin RSB prior to installation or servicing work.

Where cold refrigerant liquid lines are used, it is necessary that certain precautions be taken to avoid damage which could result from liquid expansion. Temperature increase in a piping section full of solid liquid will cause high pressure due to the expanding liquid which can possibly rupture a gasket, pipe or valve. All hand valves isolating such sections should be marked, warning against accidental closing, and must not be closed until the liquid is removed. Check valves must never be installed upstream of solenoid valves, or regulators with electric shut-off, nor should hand valves upstream of solenoid valves or downstream of check valves be closed until the liquid has been removed.

It is advisable to properly install relief devices in any section where liquid expansion could take place. Avoid all piping or control arrangements which might produce thermal or pressure shock.

For the protection of people and products, all refrigerant must be removed from the section to be worked on before a valve, strainer, or other device is opened or removed. Flanges with ODS connections are not suitable for ammonia service.

Warranty

All Refrigerating Specialties products are under warranty against defects in workmanship and materials for a period of one year from date of shipment from factory. This warranty is in force only when products are properly installed, field assembled, maintained, and operated in use and service as specifically stated in Refrigerating Specialties Catalogs or Bulletins for normal refrigeration applications, unless otherwise approved in writing by the Refrigerating Specialties Division. Defective products, or parts thereof returned to the factory with transportation charges prepaid and found

to be defective by factory inspection, will be replaced or repaired at Refrigerating Specialties option, free of charge, F.O.B. factory. Warranty does not cover products which have been altered, or repaired in the field, damaged in transit, or have suffered accidents, misuse, or abuse. Products disabled by dirt or other foreign substances will not be considered defective.

The express warranty set forth above constitutes the only warranty applicable to Refrigerating Specialties products, and is in lieu of all other warranties, expressed or implied, written including any warranty of merchantability, or fitness for a particular purpose. In no event is Refrigerating Specialties responsible for any consequential damages of any nature whatsoever. No employee, agent, dealer or other person is authorized to give any warranties on behalf of Refrigerating Specialties, nor to assume, for Refrigerating Specialties, any other liability in connection with any of its products.

