

Cat No.
FF100 Vol.2

Think Safety!

JOKWANG

Pressure Relief Valves
for UV Stamp

JSV-FF100

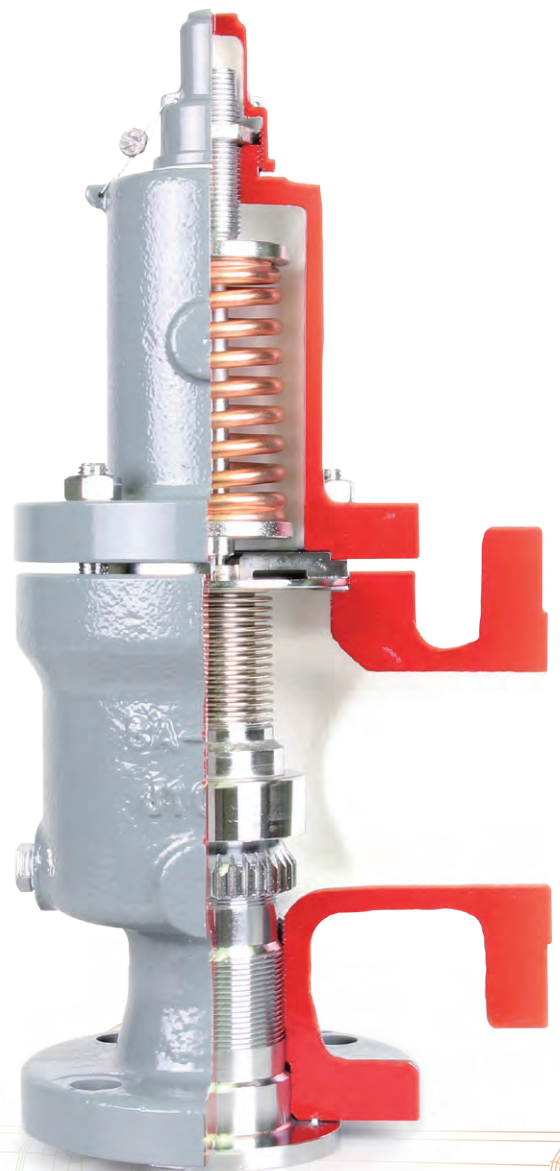

JOKWANG I.L.I. CO., LTD.



INTRODUCTION OF COMPANY

Since its establishment in 1968, JOKWANG I.L.I CO., LTD. with its JK trademark has put every effort in pioneering and specializing as one of the leading valve manufacturing companies. Its devotion has concentrated especially in the area of safety & relief valve, pressure reducing valve, stop valve and steam trap.

With almost half a century of experience, we have earned over a good reputation for quality, reliability, reasonable price and excellent performance.

We determined to contribute to serve your need for your heat control and energy saving effort through our precision design, strict testing, and precision processing. Your kind inquiries would be much appreciated, and we will do our best to give you our business suggestions on them, which can be competitive in your market. In closing, we promise for our continuous endeavor, for more research, and for development work to pay back your positive supports and encouragement.





COMPANY HISTORY

- Nov. 1968** Founded JOKWANG Industries Company in Busan, Korea
- May. 1987** Acquired K.S(Korean Industrial Standard) Mark
- Apr. 1989** Acquired Type approval from KR(Korea)
- Dec. 1992** Technical Collaboration with VENN in Japan
- Dec. 1998** Acquired ISO 9001 Certificate
- Dec. 1999** Changed Company name to JOKWANG I.L.I Co., Ltd.
- Oct. 2000** Moved to Noksan Industrial Complex in Busan, Korea
- Nov. 2003** Acquired Type approval from DNV(Norway)
- Mar. 2004** Acquired Type approval from BV(France)
- Apr. 2004** Acquired KEPIC Certificate
- Jun. 2004** Acquired Type approval from LR(UK)
- May. 2006** Acquired Safety Relief Valve ASME "UV" Stamp
- Nov. 2006** Patent registered for Pilot-Operated Safety Valve
- May. 2010** Acquired Type approval from GL(Germany)
- Apr. 2011** Acquired Safety Relief Valve ASME "UV" Stamp(Up to 6,000psig)
- Dec. 2011** Awarded Export Tower of 3 Mil. U.S Dollar
- Dec. 2011** Acquired Type approval from CCS(China)
- Dec. 2011** Acquired ISO14001 Certificate
- Mar. 2012** Acquired OHSAS18001 Certificate
- Mar. 2013** Acquired Pilot type Safety Relief Valve ASME "UV"Stamp
- Jun. 2014** Acquired Safety Relief Valve ASME "V"Stamp
- Jun. 2015** Acquired Safety Relief Valve C-Set(China)
- May. 2016** Renewed ASME "UV"Stamp
- Sep. 2016** Renewed ASME "V"Stamp

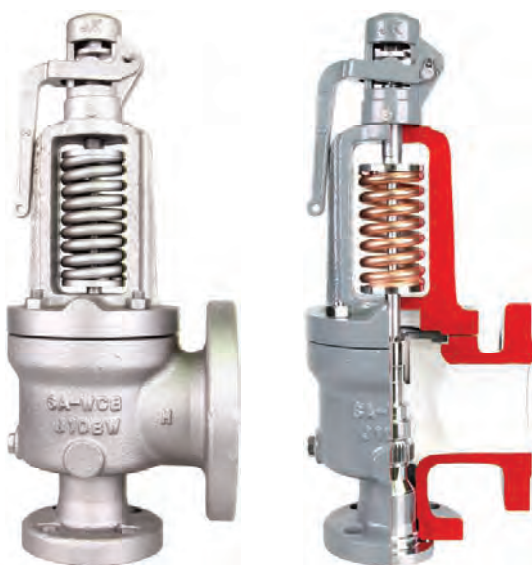

Certificate



Quality System Certificate

- 'UV' Stamp of ASME Sec. VIII
- 'V' Stamp of ASME Sec. I
- Certificate of NBBI Safety Valve Capacity
- ISO 9001 Certificate
- ISO 14001 Certificate
- OHSAS 18001 Certificate

Type Approval

- GL - Germany
- LR - United Kingdom
- DNV - Norway
- BV - France
- KR - Korea
- CCS - China



General information

01 About SRV(Safety Relief Valve)	06
02 Sizing Program Basis	09
03 Numbering System	10

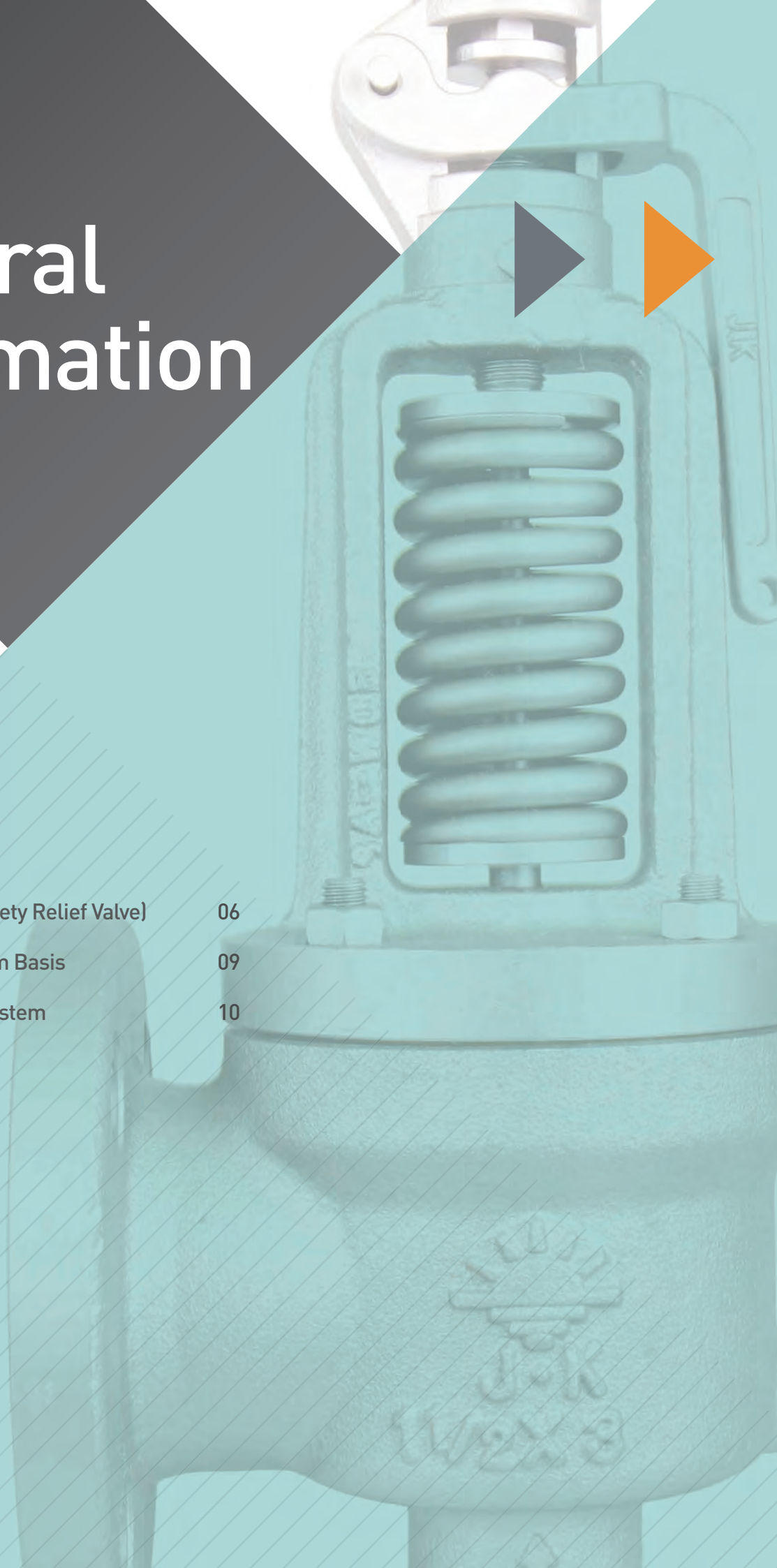

01

About SRV (Safety Relief Valve)

01 General Definition of Safety Relief Valve (SRV)

A pressure relief device is any device that can purge a system from an overpressure condition. More particularly, an SRV is a pressure relief device that is self-actuated, and whose primary purpose is the protection of life and equipment. Through a controlled discharge of a required (rated) amount of fluid at a predetermined pressure, an SRV must prevent overpressure in pressurized vessels and systems, and it operates within limits which are determined by international codes. An SRV is often the final control device in the prevention of accidents or explosions caused by overpressure.

The SRV must close at a predetermined pressure

when the system pressure has returned to a safe level at values determined by the codes.

SRVs must be designed with materials compatible with many process fluids, from simple air and water to the most corrosive and toxic media. They must also be designed to operate in a consistently smooth manner on a variety of fluids and fluid phases. These design parameters lead to a wide array of SRV products available in the market today, with the on constant being that they all must comply with the internationally recognized codes.

02 Where do SRVs fit in the process?

Every industrial process system is designed to work against a certain maximum pressure and temperature called its rating or design pressure. It is in the economic interest of the users to work as close as possible towards the maximum limits of this design pressure in order to optimize the process output, hence increase the profitability of the system.

Nowadays, pressures and flow in the process industry are controlled by electronic process systems and highly sophisticated instrumentation devices. Almost all control systems are powered by an outside power source (electric, pneumatic, hydraulic). The law requires that when everything fails regardless of the built-in redundancies, there is still an independent working device powered only by the medium it protects. This is the function of the SRV, which, when everything else

works correctly in the system, should never have to work. However, practice proves the contrary, and there are a variety of incidents which will allow the system pressure to exceed the design pressure.

Although many pressure relief devices are called SRVs, not every SRV has the same characteristics of or operational precision. Only the choice of the correct pressure safety device for the right application will assure the safety of the system and allow the user to maximize process output and minimize down-time for maintenance purposes. Making the correct choice also means avoiding interference between the process instrumentation set points in the control loop and the pressure relief device limits selected. There SRV operation al limits can vary greatly even when all are complying with the codes.

03 Pressure Relief Devices

▶ Pressure relief device

Actuated by inlet static pressure and designed to open during emergency or abnormal conditions to prevent a rise of internal fluid pressure in excess of a specified design value. The device also may be designed to prevent excessive internal vacuum. The device may be designed to prevent excessive internal vacuum. The device may be a pressure relief valve, a non-reclosing pressure relief device, or a vacuum relief valve.

▶ Pressure relief valve

A pressure relief device designed to open and relieve excess pressure and to reclose and prevent the further flow of fluid after normal conditions have been restored.

a A relief valve

It is a spring loaded pressure relief valve actuated by the static pressure upstream of the valve. The valve opens normally in proportion to the pressure increase over the opening pressure. A relief valve is used primarily with incompressible fluids.

b A safety valve

It is a spring loaded pressure relief valve actuated by the static pressure upstream of the valve and characterized by rapid opening or pop action. A safety valve is normally used with compressible fluids.

c A safety relief valve

It is a spring loaded pressure relief valve that

may be used as either a safety or relief valve depending on the application.

d A conventional pressure relief valve

It is a spring loaded pressure relief valve whose operational characteristics are directly affected by changes in the back pressure.

e A balanced pressure relief valve

It is a spring loaded pressure relief valve that incorporates a bellows or other means for minimizing the effect of back pressure on the operational characteristics of the valve.

f A pilot operated pressure relief valve

It is a pressure relief valve in which the major relieving device or main valve is combined with and controlled by a self actuated auxiliary pressure relief valve (pilot).

▶ Non-reclosing pressure relief device

A pressure relief device which remains open after operation. A manual resetting means may be provided.

▶ Rupture disk device

A non-reclosing pressure relief device actuated by static differential pressure between the inlet and outlet of the device and designed to function by the bursting of a rupture disk. A rupture disk device includes a rupture disk and a rupture disk holder.



a A rupture disk

It is a pressure containing, pressure and temperature sensitive element of a rupture disk device.

b A rupture disk holder

It is the structure which encloses and clamps the rupture disk in position.(Some disks are designed to be installed between standard flanges without holders.)

c A non fragmenting rupture disk

It is a rupture disk designed and manufactured to be installed upstream of other piping components, such as pressure relief valves, and will not impair the function of those components when the disk ruptures.

▶ Pin-actuated device

A non-reclosing pressure relief device actuated by static pressure and designed to function by buckling or breaking a pin which holds a piston or a plug in place. Upon buckling or breaking of the pin, the piston or plug instantly moves to the full open position.

* Reference
- The Safety Relief Valve Handbook - API STD 520 Part 2.

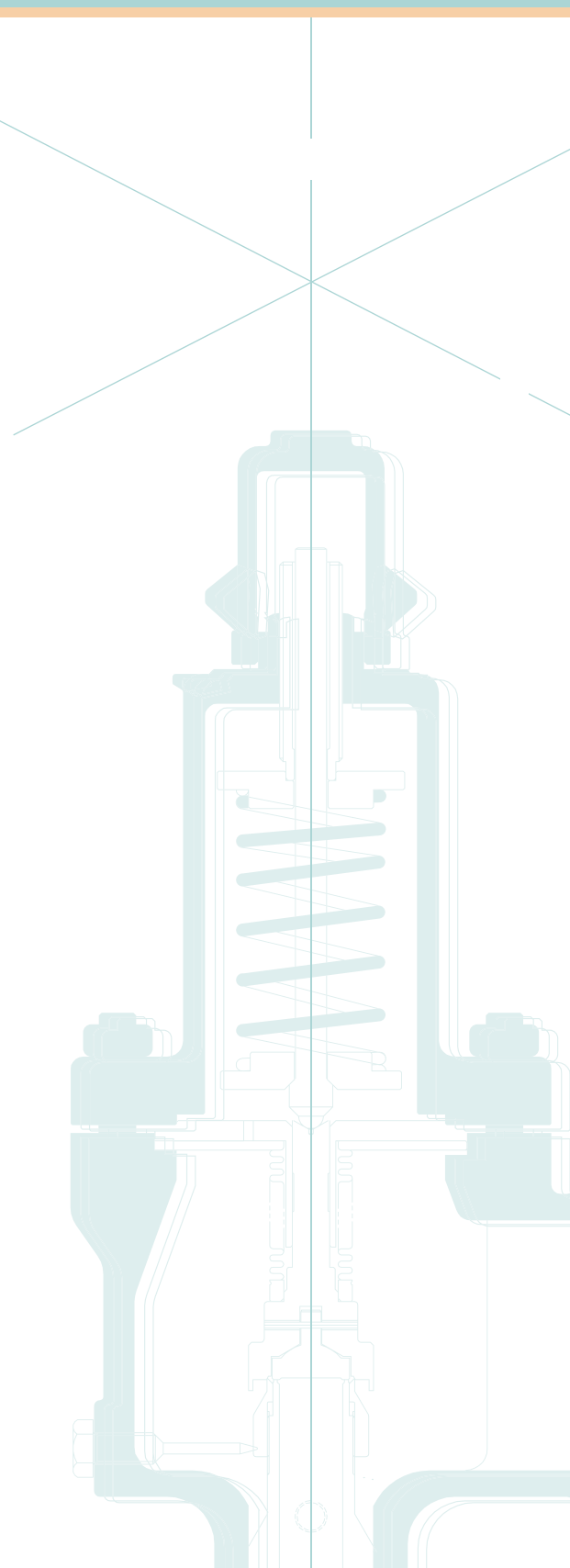

02 Sizing Program Basis



In troduction of Sizing Program

After receiving the inquiry or P/O(purchase order) from our precious customers, we input the data for specification of PSV in the COMPUTER SIZING PROGRAM(see fig.1).

This helps calculate the valve capacity and select the exact size compared than required capacity.

When we calculate the capacity, must-have information such as fluid name & states, temperature, pressure, required capacity and allowable overpressure condition(10%, 16%, 21%, etc.) are considered and reflected in the system according to the calculation standard as ASME

Sec.VIII and API STD 520 and so on.

Also the variety of pressure unit including Kg/cm²g, Barg, Mpag, Kpag, pisg and so on could be used in the system.

The whole information for the each PSV is saved in our system and the data sheet with calculation sheet(see fig. 2) based on it could be printed out automatically.

It is possible to trace the saved information of each PSV with customer's name and serial number on the customer's request.

20	010200	Tag Name(O)	PSV-001
20	010200	Service Line	
40	010800	Design Type	C Conventional
100	010700	Bonnet Type(*)	C Close
101	041900	Lever-Type(*)	L Plain Lever
102	020901	Inlet Connect Code(*)	ANSI ANSI
103	020902	Inlet Rating(*)	150 150LB
104	020903	Inlet Facing(*)	R RF
105	021001	Outlet Connect Code(*)	ANSI ANSI
106	021002	Outlet Rating(*)	150 150LB
107	021003	Outlet Facing(*)	R RF
110	020803	Size(inch(*)	0.2500 1/2"
112	074400	Orifice Designation(*)	E E(1.2.7)
200	031101	Body(*)	S-WCB SA216 WCB
201	031200	Seat(*)	S-CF8M-S SA351 CF8M(STELLITED)
202	031301	Disc(*)	SA316-S SA 276 316(STELLITED)
203	031701	Bellevows-M	NA none
300	010100	Model No	JSV-FF100
400	052200	Code(*)	A8 ASME sec. VIII
401	062502	Fluid State(*)	A AIR
402	062501	Fluid Name(*)	Air
403	062700	Mol. weight or specificOravty*	28.96
404	062900	Compressibility factor(*)	1
405	064000	Specific Heat(*)	1.4
407	069902	Pressure Unit(*)	KG barg
409	069903	Temp. Unit	C °C
410	063100	Operating Temp.	
411	063200	Blowout Temp. (* Gas/Air)	20
413	062900	Operating pressure	
414	063000	Setting pressure(*)	5
420	063600	Closing Pressure(*)	4.85
432	063700	Hydrostatic Test(*)	7.5
440	063300	Constant Back Pressure	
441	063400	Variable Back Pressure	10
450	063800	Allowable Overpressure(%)	10
490	069901	Capacity Unit	KG /min
491	069904	Area Unit	MM ²
492	062600	Required Capacity	120
494	074200	Calculated Area	26.93
496	074300	Selected Area	126.677
498	074500	Valve Capacity(*)	0.52
550	042000	Paint Color(*)	B Silver
551	042000	OAG	Y Yes
574	099997	Remark	
580	052400	Other	NA
581	052300	Fire	N No
582	062800	Viscosity(Cp)	

Fig. 1 - Sizing Program – ERP System

		Pressure Safety & Relief Valve Specification and Calculation Sheet	
		Sheet No.	Rev. No.
		02 of 114	0
		Project Name	PSV and Mechanical Integrity Development in Midland
		Project No.	
		Date	2016.04.20
		By	M. S. KIM
		Checked	Approved
		PSV-001-1	
		PSV-716	
GENERAL	PSV No.	1	3200-0011-1
GENERAL	Tag No.	2	
GENERAL	Service Line	3	PSV return to PHD Storage Drum (1200-V-711)
GENERAL	Model No.	4	JSV-FF100 / FF100
GENERAL	Quantity	5	
GENERAL	Nozzle Type	6	Full
GENERAL	Design Type	7	Below (Balanced Point)
GENERAL	Bonnet Type	8	Closed
GENERAL	Lever Type	9	No
GENERAL	Cap Type	10	Screwed
GENERAL	Size, Inlet / Outlet	11	1" X 2"
GENERAL	Inlet Rating / Facing	12	ASME C, 150 / RF
GENERAL	Outlet Rating / Facing	13	ASME C, 150 / RF
GENERAL	Body (Steel)	14	SA216 WCB
GENERAL	Bonnet	15	SA216 WCB
GENERAL	Seat	16	SA316 316-n
GENERAL	Disc	17	SA316 316-n
GENERAL	Gasket	18	ASST 4284
GENERAL	Gasket (Bonnet)	19	RTS
GENERAL	Spring	20	SA351
GENERAL	Bellevows	21	INCONEL 625-LCF
GENERAL	Approved by	22	UV
GENERAL	Comply with NACE	23	No
GENERAL	EN 15000	24	Type 3.1
GENERAL	Code	25	ASME Section VIII
GENERAL	Fire	26	No
GENERAL	Scrap Basis	27	Closed Outlet
GENERAL	Pressure Disk	28	No
GENERAL	Fluid / State	29	PENTANE / Liquid
GENERAL	Mol. Weight / Specific Gravity	30	68.6
GENERAL	Compressibility Factor	31	-
GENERAL	Rate of Specific Heat	32	-
GENERAL	Viscosity	33	0.25 cp
GENERAL	Operating / Relieving Temp.	34	40.740 °C
GENERAL	Design Min. / Design Max. Temp.	35	- / 80 °C
GENERAL	Operating / Set Pressure	36	0.5 / 4.4 barg
GENERAL	Design Pressure / C.O.D.P.	37	4.4 / 4.4 barg
GENERAL	Superimposed - Constant	38	2.2 barg
GENERAL	Superimposed - Variable	39	-
GENERAL	Back - Full-up	40	0.00 barg
GENERAL	Back - Total	41	2.200 barg
GENERAL	Allowable Overpressure	42	10%
GENERAL	Choking Pressure / Blowdown(%)	43	Min. 4.000 barg / 7%
GENERAL	Hydrostatic Test Pressure (Body)	44	6.6 barg
GENERAL	Required Capacity	45	1200 kg/h
GENERAL	Valve Actual Capacity	46	2702 kg/h
GENERAL	Calculated Orifice Area	47	0.26 m ²
GENERAL	Selected Orifice Area	48	0.710 m ²
GENERAL	Orifice Diameter	49	D(51)
GENERAL	Reaction Force	50	
GENERAL	Flow Level	51	31
GENERAL	Paint System & Color	52	Y Yes
GENERAL	Fire Cap	53	No
GENERAL	Back screen	54	Yes
GENERAL	Remarks	* Inlet Steel Bolt & Nut * Inlet Gasket & Flange Gaskets	

Fig. 2 - Data & Calculation Sheet

03

Numbering System

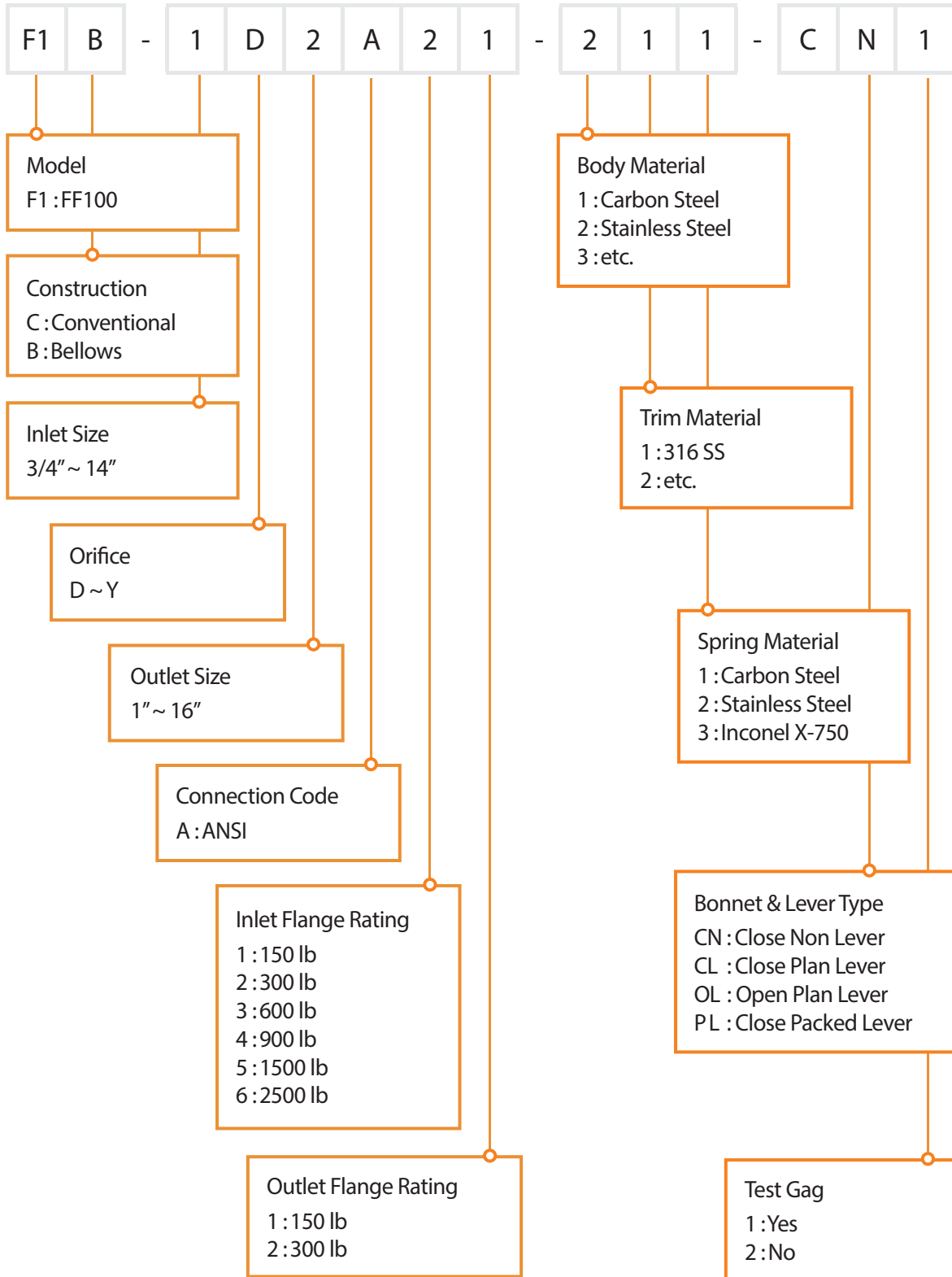



JSV-FF100

01	Product Information	12
02	Specification	14
03	Orifice Designation	15
04	Cap with Accessory	16
05	How Pressure Relief Valves Work	17
06	What is Conventional & Balanced Bellows Type	18
07	Standard Material	20
08	Dimension & Weight Table	24
09	Valve Selection	26
10	Valve Sizing	43
11	Capacity Table	48



Over almost half a century, we have been supplying a variety of safety relief valves to satisfy the highly variable requirements of customers.

JSV-FF100 as representative safety relief valve of Jokwang is designed and produced based on the accumulated technology of long experience.

We strongly recommend JSV-FF100 to protect overpressure of the vessel and process line using in the various industries.

The JSV-FF100 series is compliant with the following codes and standards.

- ASME SEC.VIII
- RELIEVING CAPACITY tested & certified by NBBI
- API STD 520 / SIZING, SELECTION AND INSTALLATION OF PRESSURE-RELIEVING DEVICE IN REFINERIES
- API STD 526 / FLANGED STEEL SAFETY-RELIEF VALVES
- API STD 527 / SEAT TIGHTNESS OF PRESSURE RELIEF VALVES
- ASME B16.34 / VALVES – FLANGED, THREADED, AND WELDING END

- Certified Discharge Capacity

JSV-FF100 is designed and manufactured in accordance with ASME Sec.VIII.

Also the discharge capacity is certified by NBBI(National Board OF Boiler and Pressure Vessel Inspections) as well.

- Excellent Seat Tightness

Disc construction of JSV-FF100 is composed of a disc and disc holder.

This kind of simple shaped disc permits a uniform pressure distribution not to make any distortion of seat, thus maintaining excellent seat tightness.

In addition, the seat is machined and lapped with a high precision to enhance the seat tightness.



- A Single adjusting ring applied

A single adjusting ring is used to minimize the simmer phenomenon and initial lifting force for the clear popping and blow down.

In case of double ring type could be obtained the full lift, also the fixed holder of single ring type can function as upper adjusting ring of double ring type. Because of that the single ring type could insure full capacity under the condition within 10% overpressure.

- International Code applied

Length(center to face dimension), Flange, Size and Pressure & Temperature limit are in accordance with the international standard.



02 Specification



Type	Conventional & Bellows
Applicable Code	ASME Sec.VIII
Size	3/4" x 1" ~ 14" x 18"
Orifice	D(0.11 in ²) ~ Y(76.078 in ²)
Set Pressure Range	15 ~ 6000 psig
Allowable Leakage	API STD 527

Orifice Area (Sq. in.)	D 0.110	E 0.196	F 0.308	G 0.506	H 0.785	J 1.293	K 1.841	L 2.862	Inlet Flange Rating ASME B 16.34	Outlet Flange Rating ASME B 16.34
Inlet X Outlet Size (inch)	(3/4)1x(1)2	1x2	1 1/2x2	1 1/2x3	1 1/2x3	2x3	3x4	3x4	150	150
	(3/4)1x(1)2	1x2	1 1/2x2	1 1/2x3	1 1/2x3	2x3	3x4	3x4	300	
	(3/4)1x(1)2	1x2	1 1/2x2	1 1/2x3	2x3	3x4	3x4	4x6	300	
	(3/4)1x(1)2	1x2	1 1/2x2	1 1/2x3	2x3	3x4	3x4	4x6	600	
	1 1/2x2	1 1/2x2	1 1/2x3	1 1/2x3	2x3	3x4	3x6	4x6	900	300
	1 1/2x2	1 1/2x2	1 1/2x3	2x3	2x3	3x4	3x6	4x6	1500	
	1 1/2x2	1 1/2x3	1 1/2x3	2x3	-	-	-	-	2500	

Orifice Area (Sq. in.)	M 3.604	N 4.337	P 6.379	Q 11.056	R 16.018	T 26.021	V 39.447	W 55.748	Y 76.078	Inlet Flange Rating ASME B 16.34	Outlet Flange Rating ASME B 16.34
Inlet X Outlet Size (inch)	4x6	4x6	4x6	6x8	6x8	8x10	10x14	12x16	14x18	150	150
	4x6	4x6	4x6	6x8	6x8	8x10	10x14	12x16	14x18	300	
	4x6	4x6	4x6	6x8	6x10	8x10	-	-	-	300	
	4x6	4x6	4x6	6x8	6x10	-	-	-	-	600	
	4x6	4x6	4x6	-	-	-	-	-	-		
	-	-	-	-	-	-	-	-	-	1500	
	-	-	-	-	-	-	-	-	-	2500	

03

Orifice Designation



Orifice	Area		Diameter	
	Sq. in	Sq. mm	In	mm
D	0.11	70.97	0.374	9.5
E	0.196	126.45	0.5	12.7
F	0.308	198.71	0.626	15.9
G	0.506	326.45	0.803	20.4
H	0.785	506.45	1.0	25.4
J	1.293	834.19	1.283	32.6
K	1.841	1187.74	1.531	38.9
K1	2.177	1404.51	1.665	42.3
L	2.862	1846.45	1.909	48.5
M	3.604	2325.16	2.142	54.4
N	4.337	2798.06	2.35	59.7
P	6.379	4115.48	2.85	72.3
P1	7.068	4559.99	3.0	76.2
Q	11.056	7132.89	3.752	95.3
Q1	13.041	8413.53	4.0748	103.5
R	16.018	10334.17	4.516	114.7
T	26.021	16787.71	5.756	146.2
T1	28.274	18241.25	6.0	152.4
V	39.447	25449.63	7.087	180.0
W	55.748	35966.38	8.425	214.0
Y	76.078	49082.48	9.842	245.0

04 Cap with Accessory

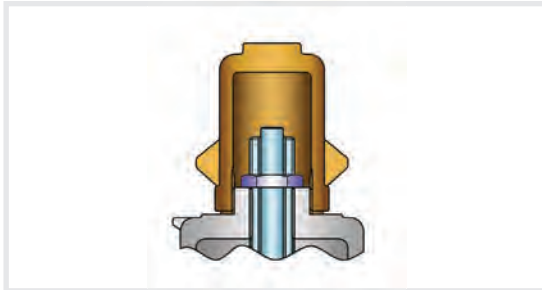

▶ None Lever

A component used to restrict access and/or protect the adjustment screw in a reclosing pressure relief device. It may or may not be a pressure containing part.

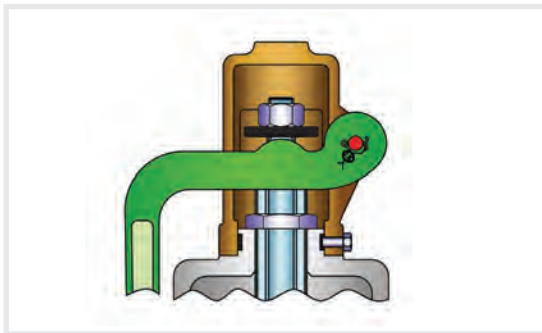

▶ Plain Lever

A device to apply an external force to the stem of a pressure relief valve to manually operate the valve at some pressure below the set pressure.

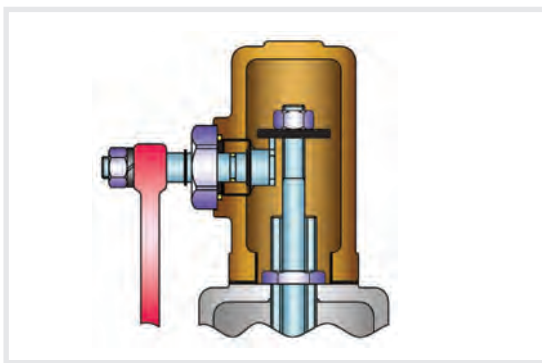

▶ Packed Lever

As indicated by the name, this lever assembly is packed around the lever shaft, so that leakage will not occur around the upper part of the valve when the valve is open or when back pressure is present. The packed lever should be used when positive protection against leakage is required.

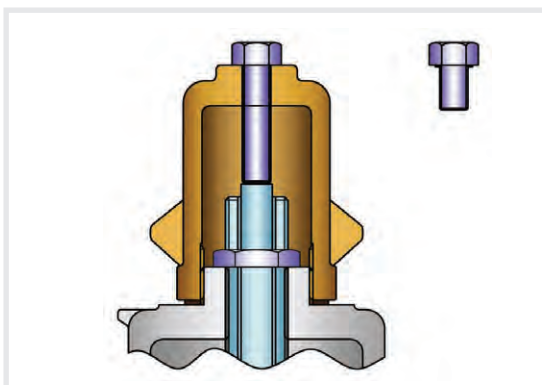

▶ Cap with Gag

A device used on re-closing pressure relief devices to prevent the device from opening. The reason why gag is used is to hold the valve closed while a valve is being subjected to hydrostatic test.

* Ref.: ASME Sec. VIII

05

How Pressure Relief Valves Work



Basic elements of spring-loaded pressure safety relief valve included an inlet nozzle connected to the vessel to be protected, movable disc which controls flow through the nozzle, and a spring which control the position of disc.

Working principal of the pressure safety relief valve is the inlet pressure to the valve is directly opposed by a spring force. Spring tension is set to keep the valve shut at normal operating pressure(Figure 1). At the set pressure the forces on the disc are balanced and the disc starts to lift and it full lifted when the vessel pressure continues rise above set pressure.

In spring operated pressure relief valves, leakage between the valve seat and disc or called "simmer" typically occurs at about 95% of set pressure(Figure 2). However, depending upon valve maintenance, seating type, and condition, simmer free operation may be possible at up to 98% of set pressure. "Simmer" is normally occurs for gas or vapor service pressure relief valve before it will "pop"(Figure 3).

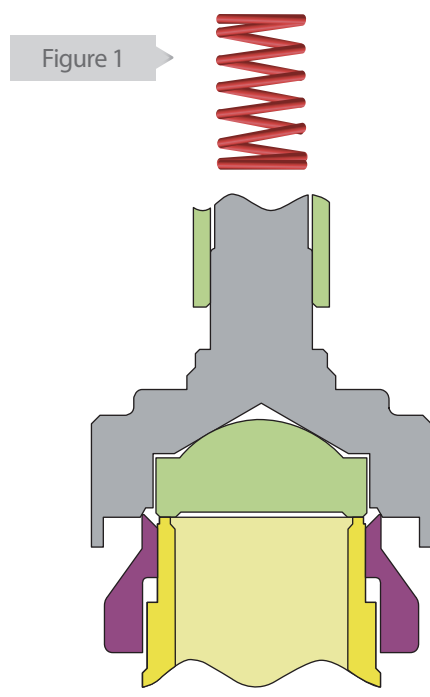

Figure 1

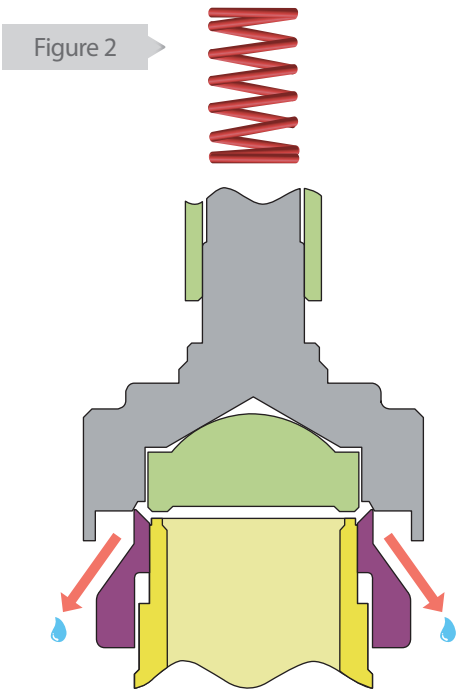

Figure 2

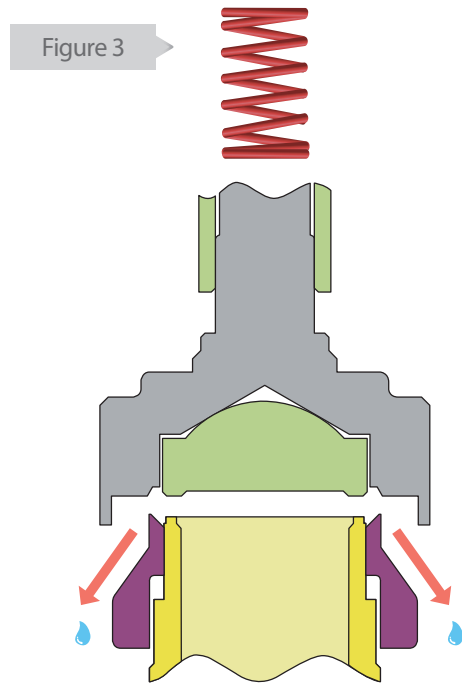

Figure 3

* Ref.: API STD 520 Part I

What is Conventional & Balanced Bellows Type

▶ Conventional Type

A conventional pressure relief valve is a self-actuated spring-loaded pressure relief valve which is designed to open at a predetermined pressure and protect a vessel or system from excess pressure by removing or relieving fluid from that vessel or system. The valve is available in small sizes commonly used for thermal relief valve applications. The basic elements of a spring-loaded pressure relief valve include an inlet nozzle connected to the vessel or system to be protected, a movable disc which controls flow through the nozzle, and a spring which controls the position of the disc. Under normal system operating conditions, the pressure at the inlet is below the set pressure and the disc is seated on the nozzle preventing flow through the nozzle.

Spring-loaded pressure relief valves are referred to by a variety of terms, such as safety valves, relief valves and safety relief valves. These terms have been traditionally applied to valves for gas/vapor service, liquid service, or multi-service applications, respectively. The more generic term, pressure relief valve, is used in the text and is applicable to all three.

The operation of a conventional spring-loaded pressure relief valve is based on a force balance. The spring-load is preset to equal the force exerted on the closed disc by the inlet fluid when the system pressure is at the set pressure of the valve. When the inlet pressure is below the set pressure, the disc remains seated on the nozzle in the closed position. When the inlet pressure exceeds set pressure, the pressure force on the disc overcomes the spring force and the valve opens. When the inlet pressure is reduced to a level below the set pressure, the valve re-closes.

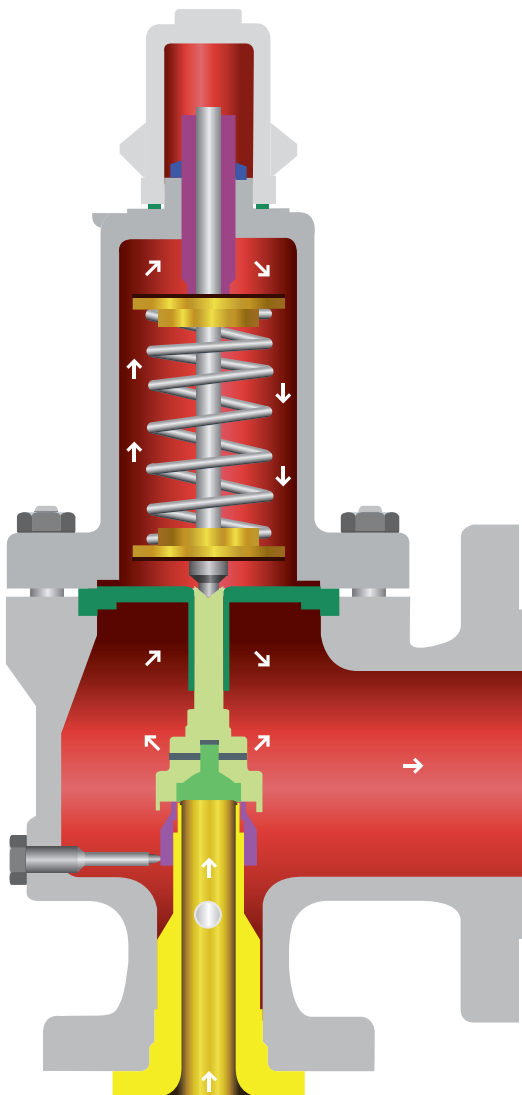

* Ref.: API STD 520 Part I



▶ Balanced Bellows Type

A balanced pressure relief valve is a spring loaded pressure relief valve which incorporates a bellows or other means of balancing the valve disc to minimize the effects of back pressure on the performance characteristics of the valve.

When a superimposed back pressure is applied to the outlet of a spring-loaded pressure relief valve, a pressure force is applied to the valve disc which is additive to the spring force. This added force increases the pressure at which an unbalanced pressure relief valve will open. If the superimposed back pressure is variable then the pressure at which the valve will open will vary. In a balanced-bellows pressure relief valve, a bellows is attached to the disc holder with a pressure area, approximately equal to the seating area of the disc. This isolates an area in the disc, approximately equal to the disc seat area, from the back pressure. With the addition of a bellows, therefore, the set pressure of the pressure relief valve will remain constant in spite of variations in back pressure. Note that the internal area of the bellows in a balanced-bellows spring-loaded pressure relief valve is referenced to atmospheric pressure in the valve bonnet. It is important to remember that the bonnet of a balanced pressure relief valve must be vented to the atmosphere at all times for the bellows to perform properly. If the valve is located where atmospheric venting would present a hazard or is not permitted by environmental regulations, the vent should be piped to a safe location that is free of back pressure that may affect the pressure relief valve set pressure.

When the superimposed back pressure is constant, the spring-load can be reduced to compensate for the effect of back pressure on set pressure, and a balanced valve is not required. Balanced pressure relief valves should be considered where the built-up back pressure is too high for a conventional pressure relief.

* Ref.: API STD 520 Part I

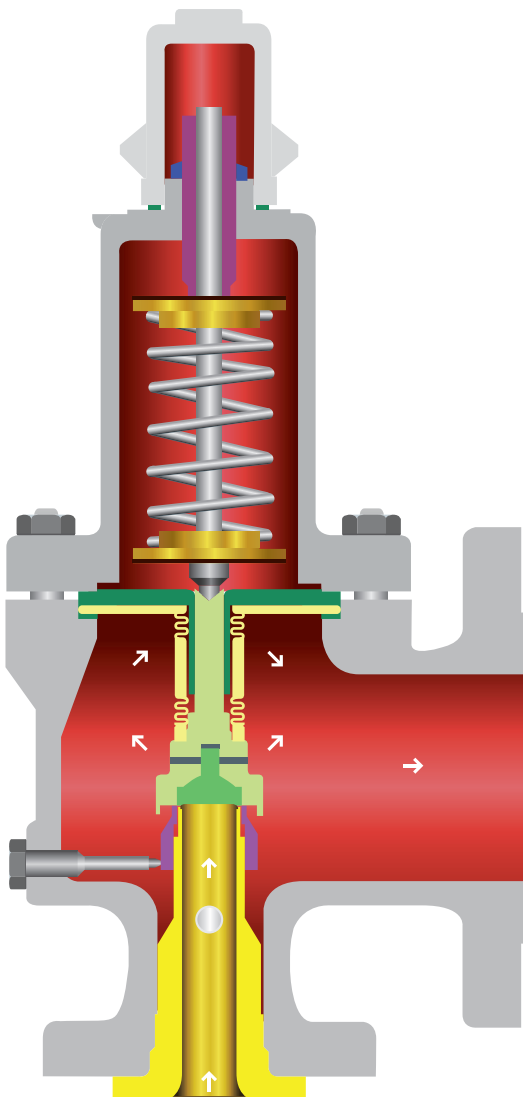

07 Standard Material

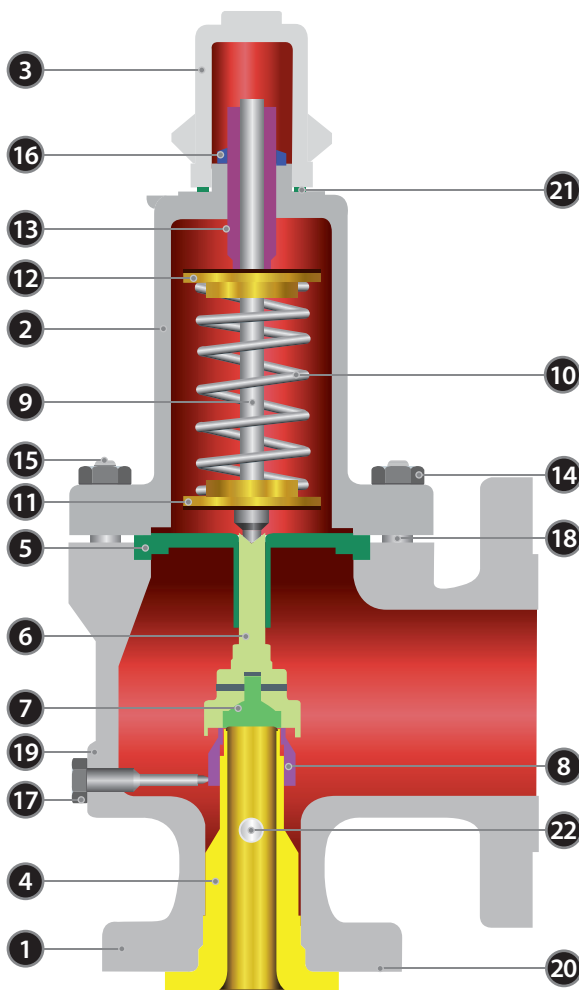

No.	Part Name	Material
1	Body	SA216 WCB
2	Bonnet	SA216 WCB
3	Cap	Carbon Steel
4	Seat	316 SS
5	Guide	316 SS
6	Holder	316 SS
7	Disc	316 SS
8	Adjust Ring	316 SS
9	Stem	316 SS
10	Spring	Carbon Steel
11	Low Spring Seat	316 SS
12	Up Spring Seat	316 SS
13	Adjust Screw	316 SS
14	Nut	A194 2H
15	Stud Bolt	A193 B7
16	Lock Nut	316 SS
17	Set Screw	316 SS
18	Bonnet Gasket	Non-Asbestos
19	Set Screw Gasket	Non-Asbestos
20	Seat Gasket	Teflon
21	Cap Gasket	Non-Asbestos
22	Drain Plug	Carbon Steel

The material could be changeable upon request.

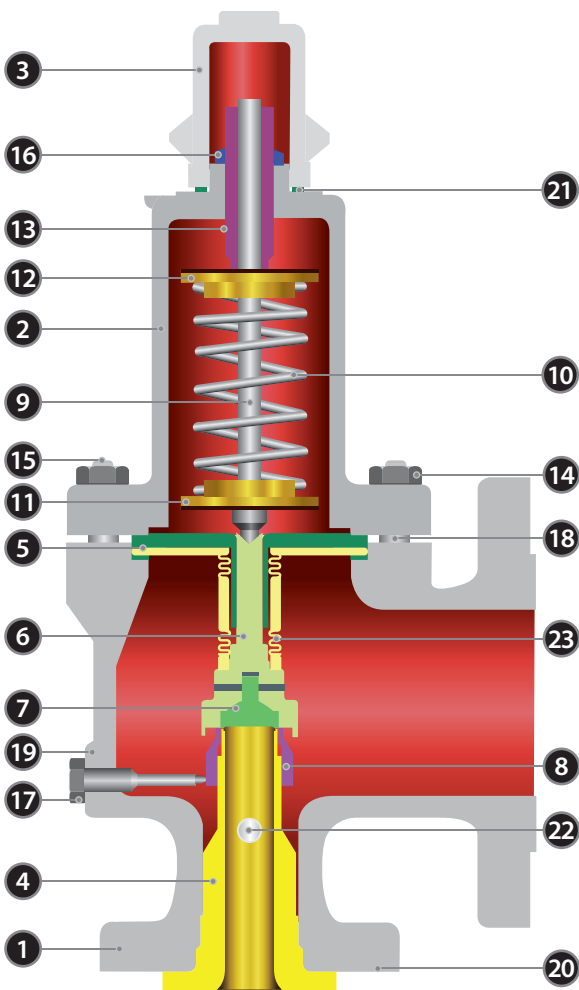

No.	Part Name	Material
1	Body	SA216 WCB
2	Bonnet	SA216 WCB
3	Cap	Carbon Steel
4	Seat	316 SS
5	Guide	316 SS
6	Holder	316 SS
7	Disc	316 SS
8	Adjust Ring	316 SS
9	Stem	316 SS
10	Spring	Carbon Steel
11	Low Spring Seat	316 SS
12	Up Spring Seat	316 SS
13	Adjust Screw	316 SS
14	Nut	A194 2H
15	Stud Bolt	A193 B7
16	Lock Nut	316 SS
17	Set Screw	316 SS
18	Bonnet Gasket	Non-Asbestos
19	Set Screw Gasket	Non-Asbestos
20	Seat Gasket	Teflon
21	Cap Gasket	Non-Asbestos
22	Drain Plug	Carbon Steel
23	Bellows	316L SS

The material could be changeable upon request.

Standard & Recommended Material Table (JSV-FF100)

		Standard			Recommended			
Material Type					Corrosive Service (316 Stainless Steel)			
Temperature		S1	S2	S3	Austenite		Sub-zero treatment	
		-29 ~ 427°C	-45 ~ 350°C	Over 427°C	C1	C2	C3	C4
No.	Part	Conventional or Bellows	Conventional or Bellows	Conventional or Bellows	Conventional	Bellows	Conventional	Bellows
1	Body	S-WCB	S-LCB or LCC (Note 4)	S-WC6 or WC9	S-CF8 or CF8M or CF3M	S-CF8 or CF8M or CF3M	S-CF8M	S-CF8M
2	Bonnet	S-WCB	S-LCB or LCC (Note 4)	S-WC6 or WC9	S-CF8 or CF8M or CF3M	S-CF8 or CF8M or CF3M	S-CF8M	S-CF8M
3	Cap	Carbon Steel	LCB or LCC (Note 4)	WC6 or WC9	CF8 or CF8M or CF3M	CF8 or CF8M or CF3M	S-CF8M	S-CF8M
4	Disc	316 SS	316 SS	Inconel	316 SS	316 SS	316 SS	316 SS
5	Seat	316 SS	316 SS	F22	316 SS	316 SS	316 SS	316 SS
6	Disc Guide	316 SS	316 SS	316 SS	316 SS	316 SS	316 SS	316 SS
7	Disc Holder	316 SS	316 SS	316 SS	316 SS	316 SS	316 SS	316 SS
8	Adjust Ring	316 SS	316 SS	316 SS	316 SS	316 SS	316 SS	316 SS
9	Plug	316 SS	316 SS	316 SS	316 SS	316 SS	316 SS	316 SS
10	Set Screw	316 SS	316 SS	316 SS	316 SS	316 SS	316 SS	316 SS
11	Spring Pin	316 SS	316 SS	316 SS	316 SS	316 SS	316 SS	316 SS
12	Bellows	316L SS	316L SS	316L SS	-	316L SS	-	316L SS
13	Spring	C.S or 316 SS	316 SS	Tungsten or x 750	316 SS or C.S + Ni Plated	C.S or C.S + Nikel Plated	316 SS	316 SS
14	Valve Stem	316 SS	316 SS	316 SS	316 SS	316 SS	316 SS	316 SS
15	Spring Seat(Low)	A105	316 SS	316 SS	316 SS	316 SS	316 SS	316 SS
16	Spring Seat(Upper)	A105	316 SS	316 SS	316 SS	316 SS	316 SS	316 SS
17	Adjust Screw	316 SS	316 SS	316 SS	316 SS	316 SS	316 SS	316 SS
18	Lock Nut	316 SS	316 SS	316 SS	316 SS	316 SS	316 SS	316 SS
19	Stus Bolt	A193 B7	A193 B8M	A193 B16	A193 B8M	A193 B8M	A193 B8M	A193 B8M
20	Stud Nut	A194 2H	A194 8M	A194 4	A194 8M	A194 8M	A194 8M	A194 8M
21	Lever	WCB	CF8M	CF8M	CF8M	CF8M	CF8M	CF8M
22	Pin	316 SS	316 SS	316 SS	316 SS	316 SS	316 SS	316 SS
23	Bonnet Gasket	Refer to Note 1 thru 3			Refer to Note 1 thru 3			
24	Set Screw Gasket							
25	Cap Gasket							
26	Seat Gasket							
27	Vent Valve	Brass	Brass	Brass	Brass	Brass	Brass	Brass

* Note

1. Applicable Gasket (No.23) : PTFE or PCTFE or Non-Asbestos, Graphite (Spiralwound or Grooved Metal, If requested)
2. Applicable Gasket(No. 24, 25, 26) : PTFE or PCTFE or Non-Asbestos
3. Gasket Selection Guide

Material	Temperature
PTFE	Max. 180°C
Non-Asbestos	Max. 200°C
Graphite	Max. 400°C
Spiralwound	Over 400°C
Grooved Metal	Over 400°C



Recommended			
Hastelloy (N10276 C276, N10665 B2)			
H1	H2	H3	H4
-60 ~ 427°C	-60 ~ 427°C	-60 ~ 427°C	-60 ~ 427°C
Conventional	Bellows	Conventional	Conventional
CW12MW or N12MV	CW12MW or N12MV	CW12MW or N12MV	CW12MW or N12MV
CW12MW or N12MV	CW12MW or N12MV	CW12MW or N12MV	CW12MW or N12MV
CW12MW or N12MV	CW12MW or N12MV	CW12MW or N12MV	CW12MW or N12MV
Hastelloy	Hastelloy	Hastelloy	Hastelloy
Hastelloy	Hastelloy	Hastelloy	Hastelloy
316 SS	Hastelloy	Hastelloy	Hastelloy
316 SS	Hastelloy	Hastelloy	Hastelloy
316 SS	Hastelloy	Hastelloy	Hastelloy
316 SS	Hastelloy	Hastelloy	Hastelloy
316 SS	Hastelloy	Hastelloy	Hastelloy
316 SS	X750	X750	X750
-	Hastelloy	-	-
316 SS	316 SS	316 SS	× 750
316 SS	316 SS	316 SS	Hastelloy
316 SS	316 SS	316 SS	Hastelloy
316 SS	316 SS	316 SS	Hastelloy
316 SS	316 SS	316 SS	Hastelloy
316 SS	316 SS	316 SS	Hastelloy
A193 B8M	A193 B8M	A193 B8M	A193 B8M
A194 8M	A194 8M	A194 8M	A194 8M
CF8M	CF8M	CF8M	CF8M
316 SS	316 SS	316 SS	316 SS
Refer to Note 1 thru 3			
Brass	Brass	Brass	Brass

Recommended			
Monel (N04400 400)			
M1	M2	M3	M4
-60 ~ 427°C	-60 ~ 427°C	-60 ~ 427°C	-60 ~ 427°C
Conventional	Bellows	Conventional	Conventional
M35-1	M35-1	M35-1	M35-1
M35-1	M35-1	M35-1	M35-1
M35-1	M35-1	M35-1	M35-1
Monel	Monel	Monel	Monel
Monel	Monel	Monel	Monel
316 SS	Monel	Monel	Monel
316 SS	Monel	Monel	Monel
316 SS	Monel	Monel	Monel
316 SS	Monel	Monel	Monel
316 SS	Monel	Monel	Monel
316 SS	X750	X750	X750
-	Monel	-	-
316 SS	316 SS	316 SS	× 750
316 SS	316 SS	316 SS	Monel
316 SS	316 SS	316 SS	Monel
316 SS	316 SS	316 SS	Monel
316 SS	316 SS	316 SS	Monel
316 SS	316 SS	316 SS	Monel
A193 B8M	A193 B8M	A193 B8M	A193 B8M
A194 8M	A194 8M	A194 8M	A194 8M
CF8M	CF8M	CF8M	CF8M
316 SS	316 SS	316 SS	316 SS
Refer to Note 1 thru 3			
Brass	Brass	Brass	Brass

Recommended			
Duplex S.S (S32750 5A, S32760 6A)			
D1	D2	D3	D4
-60 ~ 427°C	-60 ~ 427°C	-60 ~ 427°C	-60 ~ 427°C
Conventional	Bellows	Conventional	Conventional
CE3MN or CD3MWCuN	CE3MN or CD3MWCuN	CE3MN or CD3MWCuN	CE3MN or CD3MWCuN
CE3MN or CD3MWCuN	CE3MN or CD3MWCuN	CE3MN or CD3MWCuN	CE3MN or CD3MWCuN
CE3MN or CD3MWCuN	CE3MN or CD3MWCuN	CE3MN or CD3MWCuN	CE3MN or CD3MWCuN
Duplex	Duplex	Duplex	Duplex
Duplex	Duplex	Duplex	Duplex
316 SS	Duplex	Duplex	Duplex
316 SS	Duplex	Duplex	Duplex
316 SS	Duplex	Duplex	Duplex
316 SS	Duplex	Duplex	Duplex
316 SS	Duplex	Duplex	Duplex
316 SS	Duplex	Duplex	Duplex
316 SS	X750	X750	X750
-	625	-	-
316 SS	316 SS	316 SS	× 750
316 SS	316 SS	316 SS	Duplex
316 SS	316 SS	316 SS	Duplex
316 SS	316 SS	316 SS	Duplex
316 SS	316 SS	316 SS	Duplex
316 SS	316 SS	316 SS	Duplex
A193 B8M	A193 B8M	A193 B8M	A193 B8M
A194 8M	A194 8M	A194 8M	A194 8M
CF8M	CF8M	CF8M	CF8M
316 SS	316 SS	316 SS	316 SS
Refer to Note 1 thru 3			
Brass	Brass	Brass	Brass

08

Dimension & Weight Table

Dimension	A [in]	B [in]	H [in]	D [in]	T [in]	Approx. Weight (lbs)	A [in]	B [in]	H [in]	D [in]	T [in]	Approx. Weight (lbs)	A [in]	B [in]	H [in]	D [in]	T [in]	Approx. Weight (lbs)
Flange Class	150 × 150						300L × 150						300 × 150					
Valve Size	3/4 D 1												3/4 D 1					
D	3 1/2	3 3/4	11 1/2	4 1/2	1	35							3 1/2	3 3/4	11 1/2	4 1/2	1	35
	1 D 2						1 D 2						1 D 2					
	4 1/8	4 1/2	13 3/4	5	1	40	4 1/8	4 1/2	13 3/4	5	1	50	4 1/8	4 1/2	13 3/4	5	1	50
Valve Size	1 E 2						1 E 2						1 E 2					
E	4 1/8	4 1/2	13 3/4	5	1	40	4 1/8	4 1/2	13 3/4	5	1	50	4 1/8	4 1/2	13 3/4	5	1	50
Valve Size	1 1/2 F 2						1 1/2 F 2						1 1/2 F 2					
F	4 7/8	4 3/4	14 1/2	5	1 1/8	55	4 7/8	4 3/4	14 1/2	5	1 1/8	55	4 7/8	6	16	6 1/8	1 1/4	60
Valve Size	1 1/2 G 3						1 1/2 G 3						1 1/2 G 3					
G	4 7/8	4 3/4	16 1/2	6 1/16	1 3/16	45	4 7/8	4 3/4	16 1/2	6 1/16	1 3/16	45	4 7/8	6	21	7 5/8	1 5/16	65
Valve Size	1 1/2 H 3						1 1/2 H 3						2 H 3					
H	5 1/8	4 7/8	16 3/4	6 1/16	1 3/16	60	5 1/8	4 7/8	16 3/4	6 1/16	1 3/16	60	5 1/8	4 7/8	16 7/8	6 1/16	1 5/16	65
Valve Size	2 J 3						2 J 3						3 J 4					
J	5 3/8	4 7/8	17 7/16	6 1/16	1 1/4	75	5 3/8	4 7/8	17 7/16	6 1/16	1 1/4	75	7 1/4	7 1/8	23 1/4	7 3/8	1 13/16	100
Valve Size	3 K 4						3 K 4						3 K 4					
K	6 1/8	6 3/8	24 3/8	8 11/16	1 5/8	110	6 1/8	6 3/8	24 3/8	8 11/16	1 5/8	115	6 1/8	6 3/8	24 3/8	8 11/16	1 5/8	150
Valve Size	3 L 4						3 L 4						4 L 6					
L	6 1/8	6 1/2	24 3/8	8 11/16	1 5/8	140	6 1/8	6 1/2	24 3/8	8 11/16	1 5/8	145	7 1/16	7 1/8	28	9 11/16	1 3/4	220
Valve Size	4 M 6						4 M 6						4 M 6					
M	7	7 1/4	24 3/8	8 11/16	1 5/8	165	7	7 1/4	24 3/8	8 11/16	1 5/8	180	7	7 1/4	28	9 11/16	1 3/4	210
Valve Size	4 N 6						4 N 6						4 N 6					
N	7 3/4	8 1/4	31 15/16	11 1/4	1 3/4	220	7 3/4	8 1/4	31 15/16	11 1/4	1 3/4	230	7 3/4	8 1/4	31 15/16	11 1/4	1 3/4	230
Valve Size	4 P 6						4 P 6						4 P 6					
P	7 1/8	9	31 15/16	11 1/4	1 3/4	260	7 1/8	9	31 15/16	11 1/4	1 3/4	270	8 7/8	10	33 7/16	12 1/4	2 1/2	450
Valve Size	6 Q 8						6 Q 8						6 Q 8					
Q	9 7/16	9 1/2	38 5/8	13 1/2	2 1/2	620	9 7/16	9 1/2	38 5/8	13 1/2	2 1/2	630	9 7/16	9 1/2	38 5/8	13 1/2	2 1/2	630
Valve Size	6 R 8						6 R 8						6 R 10					
R	9 7/16	9 1/2	38 7/8	13 1/2	2 1/16	620	9 7/16	9 1/2	38 7/8	13 1/2	2 1/16	630	9 7/16	10 1/2	39 1/2	13 1/2	2 1/2	630
Valve Size	8 T 10						8 T 10						8 T 10					
T	10 7/8	11	45 15/16	15 9/16	2 1/4	660							10 7/8	11	45 5/16	15 9/16	2 1/4	660
Valve Size	10 V 14						10 V 14						10 V 14					
V	12	16	61 1/4		1 1/4	2000							12	16	61 1/4		1 1/4	2000
Valve Size	12 W 16						12 W 16						12 W 16					
W	14	16	69 1/4		1 5/16	2750							14	16	69 1/4		1 5/16	2750
Valve Size	14 Y 18						14 Y 18						14 Y 18					
Y	15 3/4	19 3/4	75		1 7/16	3000							15 3/4	19 3/4	75		1 5/16	3000



A [in]	B [in]	H [in]	D [in]	T [in]	Approx. Weight (lbs)	A [in]	B [in]	H [in]	D [in]	T [in]	Approx. Weight (lbs)	A [in]	B [in]	H [in]	D [in]	T [in]	Approx. Weight (lbs)	A [in]	B [in]	H [in]	D [in]	T [in]	Approx. Weight (lbs)
600 × 150						900 × 300						1500 × 300						2500 × 300					
3/4 D 1																							
3 1/2	3 3/4	11 1/2	4 1/2	1	35																		
1 D 2						1 1/2 D 2						1 1/2 D 2						1 1/2 D 3					
4 1/8	4 1/2	13 3/4	5	1	55	4 1/8	5 1/2	15 1/8	6 1/8	1 5/8	95	4 1/8	5 1/2	15 1/8	6 1/8	1 5/8	95	5 1/2	7	20 3/4	8 7/8	2 7/16	150
1 E 2						1 1/2 E 2						1 1/2 E 2						1 1/2 E 3					
4 1/8	4 1/2	13 3/4	5	1	55	4 1/8	5 1/2	15 1/8	6 1/8	1 5/8	95	4 1/8	5 1/2	15 1/8	6 1/8	1 5/8	95	5 1/2	7	20 3/4	8 7/8	2 7/16	150
1 1/2 F 2						1 1/2 F 3						1 1/2 F 3						1 1/2 F 3					
4 7/8	6	16	6 1/8	1 1/4	60	4 7/8	6 1/2	17 1/8	7 1/2	1 3/4	95	4 7/8	6 1/2	17 1/8	7 1/2	1 3/4	100	5 1/2	7	20 3/4	8 7/8	2 7/16	110
1 1/2 G 3						1 1/2 G 3						2 G 3						2 G 3					
4 7/8	6	21	7 5/8	1 5/16	65	4 7/8	6 1/2	22 1/4	8 5/16	1 11/16	95	6 1/8	6 3/4	23 1/2	9 1/16	2 3/8	150	6 1/8	6 3/4	23 1/2	9 1/16	2 3/8	150
2 H 3						2 H 3						2 H 3											
6 1/16	6 3/8	18 1/4	7	1 7/8	85	6 1/16	6 3/8	23 3/4	9 1/4	1 7/8	130	6 1/16	6 3/8	23 1/2	9 1/16	1 7/8	140						
3 J 4						3 J 4						3 J 4											
7 1/4	7 3/8	23 1/4	7 3/8	1 13/16	170	7 1/4	7 1/8	25	9	2 6/16	195	7 1/4	7 1/8	25	9	2 6/16	220						
3 K 6						3 K 6						3 K 6											
7 1/4	7 1/8	28 3/16	9 11/16	1 3/4	160	7 13/16	8 1/2	29 9/8	10 3/4	2	300	7 3/4	8 1/2	29 9/8	10 3/4	2 3/8	320						
4 L 6						4 L 6						4 L 6											
7 1/16	8	28	9 11/16	1 7/8	230	7 3/4	8 3/4	32 1/4	12 1/4	2 5/8	360	7 3/4	8 3/4	32 1/4	12 1/4	2 5/8	370						
4 M 6						4 M 6																	
7	8	28	9 11/16	1 7/8	260	7 3/4	8 3/4	32 1/4	12 1/4	2 5/8	340												
4 N 6						4 N 6																	
7 3/4	8 3/4	32 1/4	12 1/4	2 1/2	360	7 3/4	8 3/4	32 1/4	12 1/4	2 1/2	380												
4 P 6						4 P 6																	
8 7/8	10	33 7/16	12 1/4	2 1/2	500	8 7/8	10	33 7/16	12 1/4	2 1/2	510												
6 Q 8																							
9 7/16	9 1/2	38 8/8	13 1/2	2 1/2	645																		
6 R 10																							
9 7/16	10 1/2	39 1/2	13 1/2	2 1/2	645																		

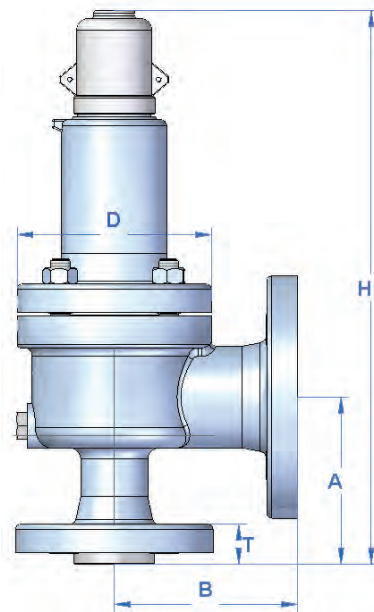

09 Valve Selection

D orifice Area : 0.11 sq. in.
Diameter : 0.374 in.

USC Units

Size	Connections ASME Flanges		Maximum Set Pressure (Psig)						Outlet Pressure Limit at 100°F (Psig)		Standard Materials	
	Inlet	Outlet	-450°F ~ -76°F	-75°F ~ -21°F	-20°F ~ 100°F	450°F	800°F	1000°F	Conventional	Bellows	Body / Bonnet	Spring
1 x 2	150	150			285	185	80		285	230	Carbon Steel	Carbon Steel
1 x 2	300	150			285	285	285		285	230		
1 x 2	300	150			740	615	410		285	230		
1 x 2	600	150			1480	1235	825		285	230		
1 1/2 x 2	900	300			2220	1845	1235		600	500		
1 1/2 x 2	1500	300			3705	3080	2060		600	500		
1 1/2 x 3	2500	300			6000	6000	3430		740	500	Chrome Molybdenm Steel	High Temp Alloy Steel
1 x 2	300	150					510	215	285	230		
1 x 2	600	150					1015	430	285	230		
1 1/2 x 2	900	300					1525	650	600	500		
1 1/2 x 2	1500	300					2540	1080	600	500		
1 1/2 x 3	2500	300					4230	1800	740	500		
1 x 2	150	150	275	275	275	180	80	20	275	230	Austenitic Stainless Steel	Stainless Steel or Alloy Steel
1 x 2	300	150	275	275	275	275	275	275	275	230		
1 x 2	300	150	720	720	720	495	420	350	275	230		
1 x 2	600	150	1440	1440	1440	975	845	700	275	230		
1 1/2 x 2	900	300	2160	2160	2160	1485	1265	1050	600	500		
1 1/2 x 2	1500	300	3600	3600	3600	2480	2110	1750	600	500		
1 1/2 x 3	2500	300	4000	6000	6000	4130	3520	2915	720	500		

Metric Units

Size	Connections ASME Flanges		Maximum Set Pressure (Barg)						Outlet Pressure Limit at 38°C (Barg)		Standard Materials	
	Inlet	Outlet	-267°C ~ -60°C	-59°C ~ -30°C	-29°C ~ 38°C	232°C	426°C	537°C	Conventional	Bellows	Body / Bonnet	Spring
1 x 2	150	150			19.6	12.7	5.5		19.6	15.8	Carbon Steel	Carbon Steel
1 x 2	300	150			19.6	19.6	19.6		19.6	15.8		
1 x 2	300	150			51.1	42.4	28.2		19.6	15.8		
1 x 2	600	150			102.0	85.1	56.8		19.6	15.8		
1 1/2 x 2	900	300			153.0	127.2	85.1		41.3	34.4		
1 1/2 x 2	1500	300			255.3	212.3	142.0		41.3	34.4		
1 1/2 x 3	2500	300			413.7	413.7	236.5		51.1	34.4		
1 x 2	300	150					35.1	14.8	19.6	15.8	Chrome Molybdenm Steel	High Temp Alloy Steel
1 x 2	600	150					70.0	29.6	19.6	15.8		
1 1/2 x 2	900	300					105.1	44.7	41.3	34.4		
1 1/2 x 2	1500	300					175.1	74.5	41.3	34.4		
1 1/2 x 3	2500	300					291.6	124.1	51.1	34.4		
1 x 2	150	150	19.0	19.0	19.0	12.4	5.5	1.4	19.0	15.8	Austenitic Stainless Steel	Stainless Steel or Alloy Steel
1 x 2	300	150	19.0	19.0	19.0	19.0	19.0	19.0	19.0	15.8		
1 x 2	300	150	49.6	49.6	49.6	34.1	28.9	24.1	19.0	15.8		
1 x 2	600	150	99.3	99.3	99.3	68.2	58.2	48.2	19.0	15.8		
1 1/2 x 2	900	300	148.9	148.9	148.9	102.3	87.2	72.3	41.3	34.4		
1 1/2 x 2	1500	300	248.2	248.2	248.2	170.9	145.5	120.6	41.3	34.4		
1 1/2 x 3	2500	300	275.8	413.7	413.7	284.8	242.7	201.0	49.6	34.4		



E orifice

Area : 0.196 sq. in.
Diameter : 0.5 in.

USC Units

Size	Connections ASME Flanges		Maximum Set Pressure (Psig)						Outlet Pressure Limit at 100°F (Psig)		Standard Materials	
	Inlet	Outlet	-450°F ~ -76°F	-75°F ~ -21°F	-20°F ~ 100°F	450°F	800°F	1000°F	Conventional	Bellows	Body / Bonnet	Spring
1 × 2	150	150			285	185	80		285	230	Carbon Steel	Carbon Steel
1 × 2	300	150			285	285	285		285	230		
1 × 2	300	150			740	615	410		285	230		
1 × 2	600	150			1480	1235	825		285	230		
1 1/2 × 2	900	300			2220	1845	1235		600	500		
1 1/2 × 2	1500	300			3705	3080	2060		600	500		
1 1/2 × 3	2500	300			6000	6000	3430		740	500		
1 × 2	300	150					510	215	285	230	Chrome Molybdenm Steel	High Temp Alloy Steel
1 × 2	600	150					1015	430	285	230		
1 1/2 × 2	900	300					1525	650	600	500		
1 1/2 × 2	1500	300					2540	1080	600	500		
1 1/2 × 3	2500	300					4230	1800	740	500		
1 × 2	150	150	275	275	275	180	80	20	275	230	Austenitic Stainless Steel	Stainless Steel or Alloy Steel
1 × 2	300	150	275	275	275	275	275	275	275	230		
1 × 2	300	150	720	720	720	495	420	350	275	230		
1 × 2	600	150	1440	1440	1440	975	845	700	275	230		
1 1/2 × 2	900	300	2160	2160	2160	1485	1265	1050	600	500		
1 1/2 × 2	1500	300	3600	3600	3600	2480	2110	1750	600	500		
1 1/2 × 3	2500	300	4000	6000	6000	4130	3520	2915	720	500		

Metric Units

Size	Connections ASME Flanges		Maximum Set Pressure (Barg)						Outlet Pressure Limit at 38°C (Barg)		Standard Materials	
	Inlet	Outlet	-267°C ~ -60°C	-59°C ~ -30°C	-29°C ~ 38°C	232°C	426°C	537°C	Conventional	Bellows	Body / Bonnet	Spring
1 × 2	150	150			19.6	12.7	5.5		19.6	15.8	Carbon Steel	Carbon Steel
1 × 2	300	150			19.6	19.6	19.6		19.6	15.8		
1 × 2	300	150			51.1	42.4	28.2		19.6	15.8		
1 × 2	600	150			102.0	85.1	56.8		19.6	15.8		
1 1/2 × 2	900	300			153.0	127.2	85.1		41.3	34.4		
1 1/2 × 2	1500	300			255.3	212.3	142.0		41.3	34.4		
1 1/2 × 3	2500	300			413.7	413.7	236.5		51.1	34.4		
1 × 2	300	150					35.1	14.8	19.6	15.8	Chrome Molybdenm Steel	High Temp Alloy Steel
1 × 2	600	150					70.0	29.6	19.6	15.8		
1 1/2 × 2	900	300					105.1	44.7	41.3	34.4		
1 1/2 × 2	1500	300					175.1	74.5	41.3	34.4		
1 1/2 × 3	2500	300					291.6	124.1	51.1	34.4		
1 × 2	150	150	19.0	19.0	19.0	12.4	5.5	1.4	19.0	15.8	Austenitic Stainless Steel	Stainless Steel or Alloy Steel
1 × 2	300	150	19.0	19.0	19.0	19.0	19.0	19.0	19.0	15.8		
1 × 2	300	150	49.6	49.6	49.6	34.1	28.9	24.1	19.0	15.8		
1 × 2	600	150	99.3	99.3	99.3	67.2	58.2	48.2	19.0	15.8		
1 1/2 × 2	900	300	148.9	148.9	148.9	102.3	87.2	72.3	41.3	34.4		
1 1/2 × 2	1500	300	248.2	248.2	248.2	170.9	145.5	120.6	41.3	34.4		
1 1/2 × 3	2500	300	275.8	413.7	413.7	284.8	242.7	201.0	49.6	34.4		

F orifice

Area : 0.308 sq. in.
Diameter : 0.626 in.

USC Units

Size	Connections ASME Flanges		Maximum Set Pressure (Psig)						Outlet Pressure Limit at 100°F (Psig)		Standard Materials	
	Inlet	Outlet	-450°F ~ -76°F	-75°F ~ -21°F	-20°F ~ 100°F	450°F	800°F	1000°F	Conventional	Bellows	Body / Bonnet	Spring
1 1/2 X 2	150	150			285	185	80		285	230	Carbon Steel	Carbon Steel
1 1/2 X 2	300	150			285	285	285		285	230		
1 1/2 X 2	300	150			740	615	410		285	230		
1 1/2 X 2	600	150			1480	1235	825		285	230		
1 1/2 X 3	900	300			2220	1845	1235		740	500		
1 1/2 X 3	1500	300			3705	3080	2060		740	500		
1 1/2 X 3	2500	300			5000	5000	3430		740	500		
1 1/2 X 2	300	150					510	215	285	230	Chrome Molybdenm Steel	High Temp Alloy Steel
1 1/2 X 2	600	150					1015	430	285	230		
1 1/2 X 3	900	300					1525	650	740	500		
1 1/2 X 3	1500	300					2540	1080	740	500		
1 1/2 X 3	2500	300					4230	1800	740	500		
1 1/2 X 2	150	150	275	275	275	180	80	20	275	230	Austenitic Stainless Steel	Stainless Steel or Alloy Steel
1 1/2 X 2	300	150	275	275	275	275	275	275	275	230		
1 1/2 X 2	300	150	720	720	720	495	420	350	275	230		
1 1/2 X 2	600	150	1440	1440	1440	975	845	700	275	230		
1 1/2 X 3	900	300	2160	2160	2160	1485	1265	1050	720	500		
1 1/2 X 3	1500	300	2200	3600	3600	2480	2110	1750	720	500		
1 1/2 X 3	2500	300	3400	5000	5000	4130	3520	2915	720	500		

Metric Units

Size	Connections ASME Flanges		Maximum Set Pressure (Barg)						Outlet Pressure Limit at 38°C (Barg)		Standard Materials	
	Inlet	Outlet	-267°C ~ -60°C	-59°C ~ -30°C	-29°C ~ 38°C	232°C	426°C	537°C	Conventional	Bellows	Body / Bonnet	Spring
1 1/2 X 2	150	150			19.6	12.7	5.5		19.6	15.8	Carbon Steel	Carbon Steel
1 1/2 X 2	300	150			19.6	19.6	19.6		19.6	15.8		
1 1/2 X 2	300	150			51.1	42.4	28.2		19.6	15.8		
1 1/2 X 2	600	150			102.0	85.1	56.8		19.6	15.8		
1 1/2 X 3	900	300			153.0	127.2	85.1		51.1	34.4		
1 1/2 X 3	1500	300			255.3	212.3	142.0		51.1	34.4		
1 1/2 X 3	2500	300			344.8	344.8	236.5		51.1	34.4		
1 1/2 X 2	300	150					35.1	14.8	19.6	15.8	Chrome Molybdenm Steel	High Temp Alloy Steel
1 1/2 X 2	600	150					70.0	29.6	19.6	15.8		
1 1/2 X 3	900	300					105.1	44.7	51.1	34.4		
1 1/2 X 3	1500	300					175.1	74.5	51.1	34.4		
1 1/2 X 3	2500	300					291.6	124.1	51.1	34.4		
1 1/2 X 2	150	150	19.0	19.0	19.0	12.4	5.5	1.4	19.0	15.8	Austenitic Stainless Steel	Stainless Steel or Alloy Steel
1 1/2 X 2	300	150	19.0	19.0	19.0	19.0	19.0	19.0	19.0	15.8		
1 1/2 X 2	300	150	49.6	49.6	49.6	34.1	28.9	24.1	19.0	15.8		
1 1/2 X 2	600	150	99.3	99.3	99.3	67.2	58.2	48.2	19.0	15.8		
1 1/2 X 3	900	300	148.9	148.9	148.9	102.3	87.2	72.3	49.6	34.4		
1 1/2 X 3	1500	300	151.6	248.2	248.2	170.9	145.5	120.6	49.6	34.4		
1 1/2 X 3	2500	300	234.4	344.8	344.8	284.8	242.7	201.0	49.6	34.4		



G orifice

Area : 0.506 sq. in.
Diameter : 0.803 in.

USC Units

Size	Connections ASME Flanges		Maximum Set Pressure (Psig)						Outlet Pressure Limit at 100°F (Psig)		Standard Materials	
	Inlet	Outlet	-450°F ~ -76°F	-75°F ~ -21°F	-20°F ~ 100°F	450°F	800°F	1000°F	Conventional	Bellows	Body / Bonnet	Spring
1 1/2 X 3	150	150			285	185	80		285	230	Carbon Steel	Carbon Steel
1 1/2 X 3	300	150			285	285	285		285	230		
1 1/2 X 3	300	150			740	615	410		285	230		
1 1/2 X 3	600	150			1480	1235	825		285	230		
1 1/2 X 3	900	300			2220	1845	1235		740	470		
2 X 3	1500	300			3705	3080	2060		740	470		
2 X 3	2500	300			3705	3705	3430		740	470		
1 1/2 X 3	300	150					510	215	285	230	Chrome Molybdenm Steel	High Temp Alloy Steel
1 1/2 X 3	600	150					1015	430	285	230		
1 1/2 X 3	900	300					1525	650	740	500		
2 X 3	1500	300					2540	1080	740	500		
2 X 3	2500	300					3705	1800	740	500		
1 1/2 X 3	150	150	275	275	275	180	80	20	275	230	Austenitic Stainless Steel	Stainless Steel or Alloy Steel
1 1/2 X 3	300	150	275	275	275	275	275	275	275	230		
1 1/2 X 3	300	150	720	720	720	495	420	350	275	230		
1 1/2 X 3	600	150	1440	1440	1440	975	845	700	275	230		
1 1/2 X 3	900	300	2160	2160	2160	1485	1265	1050	720	500		
2 X 3	1500	300	2450	3600	3600	2480	2110	1750	720	500		
2 X 3	2500	300	2600	3705	3705	3705	3520	2915	720	500		

Metric Units

Size	Connections ASME Flanges		Maximum Set Pressure (Barg)						Outlet Pressure Limit at 38°C (Barg)		Standard Materials	
	Inlet	Outlet	-267°C ~ -60°C	-59°C ~ -30°C	-29°C ~ 38°C	232°C	426°C	537°C	Conventional	Bellows	Body / Bonnet	Spring
1 1/2 X 3	150	150			19.6	12.7	5.5		19.6	15.8	Carbon Steel	Carbon Steel
1 1/2 X 3	300	150			19.6	19.6	19.6		19.6	15.8		
1 1/2 X 3	300	150			51.1	42.4	28.2		19.6	15.8		
1 1/2 X 3	600	150			102.0	85.1	56.8		19.6	15.8		
1 1/2 X 3	900	300			153.0	127.2	85.1		51.1	32.4		
2 X 3	1500	300			255.3	212.3	142.0		51.1	32.4		
2 X 3	2500	300			255.3	255.3	236.5		51.1	32.4		
1 1/2 X 3	300	150					35.1	14.8	19.6	15.8	Chrome Molybdenm Steel	High Temp Alloy Steel
1 1/2 X 3	600	150					70.0	29.6	19.6	15.8		
1 1/2 X 3	900	300					105.1	44.7	51.1	34.4		
2 X 3	1500	300					175.1	74.5	51.1	34.4		
2 X 3	2500	300					255.3	124.1	51.1	34.4		
1 1/2 X 3	150	150	19.0	19.0	19.0	12.4	5.5	1.4	19.0	15.8	Austenitic Stainless Steel	Stainless Steel or Alloy Steel
1 1/2 X 3	300	150	19.0	19.0	19.0	19.0	19.0	19.0	19.0	15.8		
1 1/2 X 3	300	150	49.6	49.6	49.6	34.1	28.9	24.1	19.0	15.8		
1 1/2 X 3	600	150	99.3	99.3	99.3	67.2	58.2	48.2	19.0	15.8		
1 1/2 X 3	900	300	148.9	148.9	148.9	102.3	87.2	72.3	49.6	34.4		
2 X 3	1500	300	168.9	248.2	248.2	170.9	145.5	120.6	49.6	34.4		
2 X 3	2500	300	179.2	248.2	248.2	248.2	242.7	201.0	49.6	34.4		

H orifice

Area : 0.785 sq. in.
Diameter : 1.0 in.

USC Units

Size	Connections ASME Flanges		Maximum Set Pressure (Psig)						Outlet Pressure Limit at 100°F (Psig)		Standard Materials	
	Inlet	Outlet	-450°F ~ -76°F	-75°F ~ -21°F	-20°F ~ 100°F	450°F	800°F	1000°F	Conventional	Bellows	Body / Bonnet	Spring
1 1/2 × 3	150	150			285	185	80		285	230	Carbon Steel	Carbon Steel
1 1/2 × 3	300	150			285	285	285		285	230		
2 × 3	300	150			740	615	410		285	230		
2 × 3	600	150			1480	1235	825		285	230		
2 × 3	900	150			2220	1845	1235		285	230		
2 × 3	1500	300			2750	2750	2060		740	415		
2 × 3	300	150					510	215	285	230	Chrome Molybdenm Steel	High Temp Alloy Steel
2 × 3	600	150					1015	430	285	230		
2 × 3	900	150					1525	650	285	230		
2 × 3	1500	300					2540	1080	740	415		
1 1/2 × 3	150	150	275	275	275	180	80	20	275	230	Austenitic Stainless Steel	Stainless Steel or Alloy Steel
1 1/2 × 3	300	150	275	275	275	275	275	275	275	230		
2 × 3	300	150	720	720	720	495	420	350	275	230		
2 × 3	600	150	1440	1440	1440	975	845	700	275	230		
2 × 3	900	150	1485	2160	2160	1485	1265	1050	275	230		
2 × 3	1500	300	1600	2750	2750	2480	2110	1750	600	415		

Metric Units

Size	Connections ASME Flanges		Maximum Set Pressure (Barg)						Outlet Pressure Limit at 38°C (Barg)		Standard Materials	
	Inlet	Outlet	-267°C ~ -60°C	-59°C ~ -30°C	-29°C ~ 38°C	232°C	426°C	537°C	Conventional	Bellows	Body / Bonnet	Spring
1 1/2 × 3	150	150			19.6	12.7	5.5		19.6	15.8	Carbon Steel	Carbon Steel
1 1/2 × 3	300	150			19.6	19.6	19.6		19.6	15.8		
2 × 3	300	150			51.1	42.4	28.2		19.6	15.8		
2 × 3	600	150			102.0	85.1	56.8		19.6	15.8		
2 × 3	900	150			153.0	127.2	85.1		19.6	15.8		
2 × 3	1500	300			189.6	189.6	142.0		51.1	28.7		
2 × 3	300	150					35.1	14.8	19.6	15.8	Chrome Molybdenm Steel	High Temp Alloy Steel
2 × 3	600	150					70.0	29.6	19.6	15.8		
2 × 3	900	150					105.1	44.7	19.6	15.8		
2 × 3	1500	300					175.1	74.5	51.1	28.7		
1 1/2 × 3	150	150	19.0	19.0	19.0	12.4	5.5	1.4	19.0	15.8	Austenitic Stainless Steel	Stainless Steel or Alloy Steel
1 1/2 × 3	300	150	19.0	19.0	19.0	19.0	19.0	19.0	19.0	15.8		
2 × 3	300	150	49.6	49.6	49.6	34.1	28.9	24.1	19.0	15.8		
2 × 3	600	150	99.3	99.3	99.3	67.2	58.2	48.2	19.0	15.8		
2 × 3	900	150	102.3	148.9	148.9	102.3	87.2	72.3	19.0	15.8		
2 × 3	1500	300	110.3	189.6	189.6	170.9	145.5	120.6	41.3	28.7		



J orifice

Area : 1.293 sq. in.
Diameter : 1.283 in.

USC Units

Size	Connections ASME Flanges		Maximum Set Pressure (Psig)						Outlet Pressure Limit at 100°F (Psig)		Standard Materials	
	Inlet	Outlet	-450°F ~ -76°F	-75°F ~ -21°F	-20°F ~ 100°F	450°F	800°F	1000°F	Conventional	Bellows	Body / Bonnet	Spring
2 × 3	150	150			285	185	80		285	230	Carbon Steel	Carbon Steel
2 × 3	300	150			285	285	285		285	230		
3 × 4	300	150			740	615	410		285	230		
3 × 4	600	150			1480	1235	825		285	230		
3 × 4	900	150			2220	1845	1235		285	230		
3 × 4	1500	300			2700	2700	2060		600	230		
3 × 4	300	150					510	215	285	230	Chrome Molybdenm Steel	High Temp Alloy Steel
3 × 4	600	150					1015	430	285	230		
3 × 4	900	150					1525	650	285	230		
3 × 4	1500	300					2540	1080	600	230		
2 × 3	150	150	275	275	275	180	80	20	275	230	Austenitic Stainless Steel	Stainless Steel or Alloy Steel
2 × 3	300	150	275	275	275	275	275	275	275	230		
3 × 4	300	150	500	720	720	495	420	350	275	230		
3 × 4	600	150	625	1440	1440	975	845	700	275	230		
3 × 4	900	150	800	2160	2160	1485	1265	1050	275	230		
3 × 4	1500	300	800	2700	2700	2480	2110	1750	600	230		

Metric Units

Size	Connections ASME Flanges		Maximum Set Pressure (Barg)						Outlet Pressure Limit at 38°C (Barg)		Standard Materials	
	Inlet	Outlet	-267°C ~ -60°C	-59°C ~ -30°C	-29°C ~ 38°C	232°C	426°C	537°C	Conventional	Bellows	Body / Bonnet	Spring
2 × 3	150	150			19.6	12.7	5.5		19.6	15.8	Carbon Steel	Carbon Steel
2 × 3	300	150			19.6	19.6	19.6		19.6	15.8		
3 × 4	300	150			51.1	42.4	28.2		19.6	15.8		
3 × 4	600	150			102.0	85.1	56.8		19.6	15.8		
3 × 4	900	150			153.0	127.2	85.1		19.6	15.8		
3 × 4	1500	300			186.2	186.2	142.0		41.3	15.8		
3 × 4	300	150					35.1	14.8	19.6	15.8	Chrome Molybdenm Steel	High Temp Alloy Steel
3 × 4	600	150					70.0	29.6	19.6	15.8		
3 × 4	900	150					105.1	44.7	19.6	15.8		
3 × 4	1500	300					175.1	74.5	41.3	15.8		
2 × 3	150	150	19.0	19.0	19.0	12.4	5.5	1.4	19.0	15.8	Austenitic Stainless Steel	Stainless Steel or Alloy Steel
2 × 3	300	150	19.0	19.0	19.0	19.0	19.0	19.0	19.0	15.8		
3 × 4	300	150	34.4	49.6	49.6	34.1	28.9	24.1	19.0	15.8		
3 × 4	600	150	43.1	99.3	99.3	67.2	58.2	48.2	19.0	15.8		
3 × 4	900	150	55.1	148.9	148.9	102.3	87.2	72.3	19.0	15.8		
3 × 4	1500	300	55.1	186.2	186.2	170.9	145.5	120.6	41.3	15.8		

K orifice

Area : 1.841 sq. in.
Diameter : 1.531 in.

USC Units

Size	Connections ASME Flanges		Maximum Set Pressure (Psig)						Outlet Pressure Limit at 100°F (Psig)		Standard Materials	
	Inlet	Outlet	-450°F ~ -76°F	-75°F ~ -21°F	-20°F ~ 100°F	450°F	800°F	1000°F	Conventional	Bellows	Body / Bonnet	Spring
3 x 4	150	150			285	185	80		285	150	Carbon Steel	Carbon Steel
3 x 4	300	150			285	285	285		285	150		
3 x 4	300	150			740	615	410		285	150		
3 x 4	600	150			1480	1235	825		285	200		
3 x 6	900	150			2220	1845	1235		285	200		
3 x 6	1500	300			2220	2220	2060		600	200		
3 x 4	300	150					510	215	285	230	Chrome Molybdenm Steel	High Temp Alloy Steel
3 x 4	600	150					1015	430	285	230		
3 x 6	900	150					1525	650	285	230		
3 x 6	1500	300					2220	1080	600	230		
3 x 4	150	150	275	275	275	180	80	20	275	230	Austenitic Stainless Steel	Stainless Steel or Alloy Steel
3 x 4	300	150	275	275	275	275	275	275	275	230		
3 x 4	300	150	525	720	720	495	420	350	275	230		
3 x 4	600	150	600	1440	1440	975	845	700	275	230		
3 x 6	900	150	600	2160	2160	1485	1265	1050	275	230		
3 x 6	1500	300	750	2220	2220	2220	2110	1750	600	230		

Metric Units

Size	Connections ASME Flanges		Maximum Set Pressure (Barg)						Outlet Pressure Limit at 38°C (Barg)		Standard Materials	
	Inlet	Outlet	-267°C ~ -60°C	-59°C ~ -30°C	-29°C ~ 38°C	232°C	426°C	537°C	Conventional	Bellows	Body / Bonnet	Spring
3 x 4	150	150			19.6	12.7	5.5		19.6	10.3	Carbon Steel	Carbon Steel
3 x 4	300	150			19.6	19.6	19.6		19.6	10.3		
3 x 4	300	150			51.1	42.4	28.2		19.6	10.3		
3 x 4	600	150			102.0	85.1	56.8		19.6	13.8		
3 x 6	900	150			153.1	127.2	85.1		19.6	13.8		
3 x 6	1500	300			153.1	153.1	142.0		41.3	13.8		
3 x 4	300	150					35.1	14.8	19.6	15.8	Chrome Molybdenm Steel	High Temp Alloy Steel
3 x 4	600	150					69.9	29.6	19.6	15.8		
3 x 6	900	150					105.1	44.7	19.6	15.8		
3 x 6	1500	300					153.0	74.5	41.3	15.8		
3 x 4	150	150	19.0	19.0	19.0	12.4	5.5	1.4	19.0	15.8	Austenitic Stainless Steel	Stainless Steel or Alloy Steel
3 x 4	300	150	19.0	19.0	19.0	19.0	19.0	19.0	19.0	15.8		
3 x 4	300	150	36.1	49.6	49.6	34.1	28.9	24.1	19.0	15.8		
3 x 4	600	150	41.3	99.3	99.3	67.2	58.2	48.2	19.0	15.8		
3 x 6	900	150	41.3	148.9	148.9	102.3	87.2	72.3	19.0	15.8		
3 x 6	1500	300	51.7	153.1	153.1	153.1	145.5	120.6	41.3	15.8		



L orifice

Area : 2.862 sq. in.
Diameter : 1.909 in.

USC Units

Size	Connections ASME Flanges		Maximum Set Pressure (Psig)						Outlet Pressure Limit at 100°F (Psig)		Standard Materials	
	Inlet	Outlet	-450°F ~ -76°F	-75°F ~ -21°F	-20°F ~ 100°F	450°F	800°F	1000°F	Conventional	Bellows	Body / Bonnet	Spring
3 × 4	150	150			285	185	80		285	100	Carbon Steel	Carbon Steel
3 × 4	300	150			285	285	285		285	100		
4 × 6	300	150			740	615	410		285	170		
4 × 6	600	150			1000	1000	825		285	170		
4 × 6	900	150			1500	1500	1235		285	170		
4 × 6	1500	150			1500	1500	1500		285	170		
4 × 6	300	150					510	215	285	170	Chrome Molybdenm Steel	High Temp Alloy Steel
4 × 6	600	150					1000	430	285	170		
4 × 6	900	150					1500	650	285	170		
4 × 6	1500	150					1500	1080	600	170		
3 × 4	150	150	275	275	275	180	80	20	275	100	Austenitic Stainless Steel	Stainless Steel or Alloy Steel
3 × 4	300	150	275	275	275	180	80	20	275	100		
4 × 6	300	150	535	720	720	495	420	350	275	170		
4 × 6	600	150	535	1000	1000	975	845	700	275	170		
4 × 6	900	150	700	1500	1500	1485	1265	1050	275	170		

Metric Units

Size	Connections ASME Flanges		Maximum Set Pressure (Barg)						Outlet Pressure Limit at 38°C (Barg)		Standard Materials	
	Inlet	Outlet	-267°C ~ -60°C	-59°C ~ -30°C	-29°C ~ 38°C	232°C	426°C	537°C	Conventional	Bellows	Body / Bonnet	Spring
3 × 4	150	150			19.6	12.7	5.5		19.6	6.8	Carbon Steel	Carbon Steel
3 × 4	300	150			19.6	19.6	19.6		19.6	6.8		
4 × 6	300	150			51.1	42.4	28.2		19.6	11.7		
4 × 6	600	150			68.9	68.9	56.8		19.6	11.7		
4 × 6	900	150			103.4	103.4	85.1		19.6	11.7		
4 × 6	1500	150			103.4	103.4	103.4		19.6	11.7		
4 × 6	300	150					35.1	14.8	19.6	11.7	Chrome Molybdenm Steel	High Temp Alloy Steel
4 × 6	600	150					68.9	29.6	19.6	11.7		
4 × 6	900	150					103.4	44.7	19.6	11.7		
4 × 6	1500	150					103.4	74.5	41.3	11.7		
3 × 4	150	150	19.0	19.0	19.0	12.4	5.5	1.4	19.0	6.8	Austenitic Stainless Steel	Stainless Steel or Alloy Steel
3 × 4	300	150	19.0	19.0	19.0	19.0	19.0	19.0	19.0	6.8		
4 × 6	300	150	36.8	49.6	49.6	34.1	28.9	24.1	19.0	11.7		
4 × 6	600	150	36.8	68.9	68.9	67.2	58.2	48.2	19.0	11.7		
4 × 6	900	150	48.2	103.4	103.4	102.3	87.2	72.3	19.0	11.7		

M orifice

Area : 3.604 sq. in.
Diameter : 2.142 in.

USC Units

Size	Connections ASME Flanges		Maximum Set Pressure (Psig)						Outlet Pressure Limit at 100°F (Psig)		Standard Materials	
	Inlet	Outlet	-450°F ~ -76°F	-75°F ~ -21°F	-20°F ~ 100°F	450°F	800°F	1000°F	Conventional	Bellows	Body / Bonnet	Spring
4 × 6	150	150			285	185	80		285	80	Carbon Steel	Carbon Steel
4 × 6	300	150			285	285	285		285	80		
4 × 6	300	150			740	615	410		285	160		
4 × 6	600	150			1100	1100	825		285	160		
4 × 6	900	150			1100	1100	1100		285	160		
4 × 6	300	150					510	215	285	160	Chrome Molybdenm Steel	High Temp Alloy Steel
4 × 6	600	150					1000	430	285	160		
4 × 6	900	150					1100	650	285	160		
4 × 6	150	150	275	275	275	180	80	20	275	80	Austenitic Stainless Steel	Stainless Steel or Alloy Steel
4 × 6	300	150	275	275	275	275	275	275	275	80		
4 × 6	300	150	525	720	720	495	420	350	275	160		
4 × 6	600	150	600	1100	1100	975	845	700	275	160		

Metric Units

Size	Connections ASME Flanges		Maximum Set Pressure (Barg)						Outlet Pressure Limit at 38°C (Barg)		Standard Materials	
	Inlet	Outlet	-267°C ~ -60°C	-59°C ~ -30°C	-29°C ~ 38°C	232°C	426°C	537°C	Conventional	Bellows	Body / Bonnet	Spring
4 × 6	150	150			19.6	12.7	5.5		19.6	5.5	Carbon Steel	Carbon Steel
4 × 6	300	150			19.6	19.6	19.6		19.6	5.5		
4 × 6	300	150			51.1	42.4	28.2		19.6	11.0		
4 × 6	600	150			75.8	75.8	56.8		19.6	11.0		
4 × 6	900	150			75.8	75.8	75.8		19.6	11.0		
4 × 6	300	150					35.1	14.8	19.6	11.0	Chrome Molybdenm Steel	High Temp Alloy Steel
4 × 6	600	150					68.9	29.6	19.6	11.0		
4 × 6	900	150					75.8	44.7	19.6	11.0		
4 × 6	150	150	19.0	19.0	19.0	12.4	5.5	1.4	19.0	5.5	Austenitic Stainless Steel	Stainless Steel or Alloy Steel
4 × 6	300	150	19.0	19.0	19.0	19.0	19.0	19.0	19.0	5.5		
4 × 6	300	150	36.2	49.6	49.6	34.1	28.9	24.1	19.0	11.0		
4 × 6	600	150	41.3	75.8	75.8	67.2	58.2	48.2	19.0	11.0		



N orifice

Area : 4.337 sq. in.
Diameter : 2.35 in.

USC Units

Size	Connections ASME Flanges		Maximum Set Pressure (Psig)						Outlet Pressure Limit at 100°F (Psig)		Standard Materials	
	Inlet	Outlet	-450°F ~ -76°F	-75°F ~ -21°F	-20°F ~ 100°F	450°F	800°F	1000°F	Conventional	Bellows	Body / Bonnet	Spring
4 × 6	150	150			285	185	80		285	80	Carbon Steel	Carbon Steel
4 × 6	300	150			285	285	285		285	80		
4 × 6	300	150			740	615	410		285	160		
4 × 6	600	150			1000	1000	825		285	160		
4 × 6	900	150			1000	1000	1000		285	160		
4 × 6	300	150					510	215	285	160	Chrome Molybdenm Steel	High Temp Alloy Steel
4 × 6	600	150					1000	430	285	160		
4 × 6	900	150					1000	650	285	160		
4 × 6	150	150	275	275	275	180	80	20	275	80	Austenitic Stainless Steel	Stainless Steel or Alloy Steel
4 × 6	300	150	275	275	275	275	275	275	275	80		
4 × 6	300	150	450	720	720	495	420	350	275	160		
4 × 6	600	150	500	1000	1000	975	845	700	275	160		

Metric Units

Size	Connections ASME Flanges		Maximum Set Pressure (Barg)						Outlet Pressure Limit at 38°C (Barg)		Standard Materials	
	Inlet	Outlet	-267°C ~ -60°C	-59°C ~ -30°C	-29°C ~ 38°C	232°C	426°C	537°C	Conventional	Bellows	Body / Bonnet	Spring
4 × 6	150	150			19.6	12.7	5.5		19.6	5.5	Carbon Steel	Carbon Steel
4 × 6	300	150			19.6	19.6	19.6		19.6	5.5		
4 × 6	300	150			51.1	42.4	28.2		19.6	11.0		
4 × 6	600	150			68.9	68.9	56.8		19.6	11.0		
4 × 6	900	150			68.9	68.9	68.9		19.6	11.0		
4 × 6	300	150					35.1	14.8	19.6	11.0	Chrome Molybdenm Steel	High Temp Alloy Steel
4 × 6	600	150					68.9	29.6	19.6	11.0		
4 × 6	900	150					68.9	44.7	19.6	11.0		
4 × 6	150	150	19.0	19.0	19.0	12.4	5.5	1.4	19.0	5.5	Austenitic Stainless Steel	Stainless Steel or Alloy Steel
4 × 6	300	150	19.0	19.0	19.0	19.0	19.0	19.0	19.0	5.5		
4 × 6	300	150	31.0	49.6	49.6	34.1	28.9	24.1	19.0	11.0		
4 × 6	600	150	34.4	68.9	68.9	67.2	58.2	48.2	19.0	11.0		

Porifice

Area : 6.379 sq. in.
Diameter : 2.85 in.

USC Units

Size	Connections ASME Flanges		Maximum Set Pressure (Psig)						Outlet Pressure Limit at 100°F (Psig)		Standard Materials	
	Inlet	Outlet	-450°F ~ -76°F	-75°F ~ -21°F	-20°F ~ 100°F	450°F	800°F	1000°F	Conventional	Bellows	Body / Bonnet	Spring
4 × 6	150	150			285	185	80		285	80	Carbon Steel	Carbon Steel
4 × 6	300	150			285	285	285		285	80		
4 × 6	300	150			525	525	410		285	150		
4 × 6	600	150			1000	1000	825		285	150		
4 × 6	900	150			1000	1000	1000		285	150		
4 × 6	300	150					510	215	285	150	Chrome Molybdenm Steel	High Temp Alloy Steel
4 × 6	600	150					1000	430	285	160		
4 × 6	900	150					1000	650	285	160		
4 × 6	150	150	175	275	275	180	80	20	275	80	Austenitic Stainless Steel	Stainless Steel or Alloy Steel
4 × 6	300	150	175	275	275	275	275	275	275	80		
4 × 6	300	150	300	525	525	495	420	350	275	160		
4 × 6	600	150	480	1000	1000	975	845	700	275	160		

Metric Units

Size	Connections ASME Flanges		Maximum Set Pressure (Barg)						Outlet Pressure Limit at 38°C (Barg)		Standard Materials	
	Inlet	Outlet	-267°C ~ -60°C	-59°C ~ -30°C	-29°C ~ 38°C	232°C	426°C	537°C	Conventional	Bellows	Body / Bonnet	Spring
4 × 6	150	150			19.6	12.7	5.5		19.6	5.5	Carbon Steel	Carbon Steel
4 × 6	300	150			19.6	19.6	19.6		19.6	5.5		
4 × 6	300	150			36.2	36.2	28.2		19.6	10.3		
4 × 6	600	150			68.9	68.9	56.8		19.6	10.3		
4 × 6	900	150			68.9	68.9	68.9		19.6	10.3		
4 × 6	300	150					35.1	14.8	19.6	10.3	Chrome Molybdenm Steel	High Temp Alloy Steel
4 × 6	600	150					68.9	29.6	19.6	11.0		
4 × 6	900	150					68.9	44.7	19.6	11.0		
4 × 6	150	150	12.0	19.0	19.0	12.4	5.5	1.4	19.0	5.5	Austenitic Stainless Steel	Stainless Steel or Alloy Steel
4 × 6	300	150	12.0	19.0	19.0	19.0	19.0	19.0	19.0	5.5		
4 × 6	300	150	20.6	36.2	36.2	34.1	28.9	24.1	19.0	11.0		
4 × 6	600	150	33.1	68.9	68.9	67.2	58.2	48.2	19.0	11.0		



Q orifice

Area : 11.056 sq. in.
Diameter : 3.752 in.

USC Units

Size	Connections ASME Flanges		Maximum Set Pressure (Psig)						Outlet Pressure Limit at 100°F (Psig)		Standard Materials	
	Inlet	Outlet	-450°F ~ -76°F	-75°F ~ -21°F	-20°F ~ 100°F	450°F	800°F	1000°F	Conventional	Bellows	Body / Bonnet	Spring
6 × 8	150	150			165	165	80		115	70	Carbon Steel	Carbon Steel
6 × 8	300	150			165	165	165		115	70		
6 × 8	300	150			300	300	300		115	115		
6 × 8	600	150			600	600	600		115	115		
6 × 8	300	150					165	165	115	115	Chrome Molybdenm Steel	High Temp Alloy Steel
6 × 8	600	150					600	430	115	115		
6 × 8	150	150	165	165	165	165	80	20	115	70	Austenitic Stainless Steel	Stainless Steel or Alloy Steel
6 × 8	300	150	165	165	165	165	165	165	115	70		
6 × 8	300	150	250	300	300	300	300	300	115	115		
6 × 8	600	150	300	600	600	600	600	600	115	115		

Metric Units

Size	Connections ASME Flanges		Maximum Set Pressure (Barg)						Outlet Pressure Limit at 38°C (Barg)		Standard Materials	
	Inlet	Outlet	-267°C ~ -60°C	-59°C ~ -30°C	-29°C ~ 38°C	232°C	426°C	537°C	Conventional	Bellows	Body / Bonnet	Spring
6 × 8	150	150			11.3	11.3	5.5		7.9	4.8	Carbon Steel	Carbon Steel
6 × 8	300	150			11.3	11.3	11.3		7.9	4.8		
6 × 8	300	150			20.6	20.6	20.6		7.9	7.9		
6 × 8	600	150			41.3	41.3	41.3		7.9	7.9		
6 × 8	300	150					11.3	11.3	7.9	7.9	Chrome Molybdenm Steel	High Temp Alloy Steel
6 × 8	600	150					41.3	29.6	7.9	7.9		
6 × 8	150	150	11.3	11.3	11.3	11.3	5.5	1.4	7.9	4.8	Austenitic Stainless Steel	Stainless Steel or Alloy Steel
6 × 8	300	150	11.3	11.3	11.3	11.3	11.3	11.3	7.9	4.8		
6 × 8	300	150	17.2	20.6	20.6	20.6	20.6	20.6	7.9	7.9		
6 × 8	600	150	20.6	41.3	41.3	41.3	41.3	41.3	7.9	7.9		

R orifice

Area : 16.018 sq. in.
Diameter : 4.516 in.

USC Units

Size	Connections ASME Flanges		Maximum Set Pressure (Psig)						Outlet Pressure Limit at 100°F (Psig)		Standard Materials	
	Inlet	Outlet	-450°F ~ -76°F	-75°F ~ -21°F	-20°F ~ 100°F	450°F	800°F	1000°F	Conventional	Bellows	Body / Bonnet	Spring
6 × 8	150	150			100	100	80		60	60	Carbon Steel	Carbon Steel
6 × 8	300	150			100	100	100		60	60		
6 × 10	300	150			230	230	230		100	100		
6 × 10	600	150			300	300	300		100	100		
6 × 8	300	150					100	100	100	100	Chrome Molybdenm Steel	High Temp Alloy Steel
6 × 10	600	150					300	300	100	100		
6 × 8	150	150	55	100	100	100	80	20	60	60	Austenitic Stainless Steel	Stainless Steel or Alloy Steel
6 × 8	300	150	55	100	100	100	100	100	60	60		
6 × 10	300	150	150	230	230	230	230	230	100	100		
6 × 10	600	150	200	300	300	300	300	300	100	100		

Metric Units

Size	Connections ASME Flanges		Maximum Set Pressure (Barg)						Outlet Pressure Limit at 38°C (Barg)		Standard Materials	
	Inlet	Outlet	-267°C ~ -60°C	-59°C ~ -30°C	-29°C ~ 38°C	232°C	426°C	537°C	Conventional	Bellows	Body / Bonnet	Spring
6 × 8	150	150			6.8	6.8	5.5		4.1	4.1	Carbon Steel	Carbon Steel
6 × 8	300	150			6.8	6.8	6.8		4.1	4.1		
6 × 10	300	150			15.8	15.8	15.8		6.8	6.8		
6 × 10	600	150			20.6	20.6	20.6		6.8	6.8		
6 × 8	300	150					6.8	6.8	6.8	6.8	Chrome Molybdenm Steel	High Temp Alloy Steel
6 × 10	600	150					20.6	20.6	6.8	6.8		
6 × 8	150	150	3.7	6.8	6.8	6.8	5.5	1.3	4.1	4.1	Austenitic Stainless Steel	Stainless Steel or Alloy Steel
6 × 8	300	150	3.7	6.8	6.8	6.8	6.8	6.8	4.1	4.1		
6 × 10	300	150	10.3	15.8	15.8	15.8	15.8	15.8	6.8	6.8		
6 × 10	600	150	13.7	20.6	20.6	20.6	20.6	20.6	6.8	6.8		



T orifice

Area : 26.021 sq. in.
Diameter : 5.756 in.

USC Units

Size	Connections ASME Flanges		Maximum Set Pressure (Psig)						Outlet Pressure Limit at 100°F (Psig)		Standard Materials	
	Inlet	Outlet	-450°F ~ -76°F	-75°F ~ -21°F	-20°F ~ 100°F	450°F	800°F	1000°F	Conventional	Bellows	Body / Bonnet	Spring
8 × 10	150	150			65	65	65		30	30	Carbon Steel	Carbon Steel
8 × 10	300	150			65	65	65		30	30		
8 × 10	300	150			120	120	120		60	60		
8 × 10	300	150			300	300	300		100	100		
8 × 10	300	150					120	100	60	60	Chrome Molybdenm Steel	High Temp Alloy Steel
8 × 10	300	150					300	215	100	100		
8 × 10	150	150	50	65	65	65	65	20	30	30	Austenitic Stainless Steel	Stainless Steel or Alloy Steel
8 × 10	300	150	50	65	65	65	65	65	30	30		
8 × 10	300	150	65	120	120	120	120	120	60	60		

Metric Units

Size	Connections ASME Flanges		Maximum Set Pressure (Barg)						Outlet Pressure Limit at 38°C (Barg)		Standard Materials	
	Inlet	Outlet	-267°C ~ -60°C	-59°C ~ -30°C	-29°C ~ 38°C	232°C	426°C	537°C	Conventional	Bellows	Body / Bonnet	Spring
8 × 10	150	150			4.4	4.4	4.4		2.0	2.0	Carbon Steel	Carbon Steel
8 × 10	300	150			4.4	4.4	4.4		2.0	2.0		
8 × 10	300	150			8.2	8.2	8.2		4.1	4.1		
8 × 10	300	150			20.6	20.6	20.6		6.8	6.8		
8 × 10	300	150					8.2	6.8	4.1	4.1	Chrome Molybdenm Steel	High Temp Alloy Steel
8 × 10	300	150					20.6	14.8	6.8	6.8		
8 × 10	150	150	3.4	4.4	4.4	4.4	4.4	1.4	2.0	2.0	Austenitic Stainless Steel	Stainless Steel or Alloy Steel
8 × 10	300	150	3.4	4.4	4.4	4.4	4.4	4.4	2.0	2.0		
8 × 10	300	150	4.4	8.2	8.2	8.2	8.2	8.2	4.1	4.1		

V orifice

Area : 39.447 sq. in.
Diameter : 7.087in.

USC Units

Size	Connections ASME Flanges		Maximum Set Pressure (Psig)				Outlet Pressure Limit at 100°F (Psig)		Standard Materials	
	Inlet	Outlet	-20°F ~ 100°F	450°F	800°F	1000°F	Conventional	Bellows	Body / Bonnet	Spring
10 × 14	150	150	154	154			30	30	Carbon Steel	Carbon Steel
10 × 14	300	150	300	300			100	100		
10 × 14	150	150			154	154	30	30	Chrome Molybdenm Steel	High Temp Alloy Steel
10 × 14	300	150			154	154	30	30		

Metric Units

Size	Connections ASME Flanges		Maximum Set Pressure (Barg)				Outlet Pressure Limit at 38°C (Barg)		Standard Materials	
	Inlet	Outlet	-29°C ~ 38°C	232°C	426°C	537°C	Conventional	Bellows	Body / Bonnet	Spring
10 × 14	150	150	10.6	10.6			2.0	2.0	Carbon Steel	Carbon Steel
10 × 14	300	150	20.6	20.6			6.8	6.8		
10 × 14	150	150			10.6	10.6	2.0	2.0	Chrome Molybdenm Steel	High Temp Alloy Steel
10 × 14	300	150			10.6	10.6	2.0	2.0		



W orifice

Area : 55.748 sq. in.
Diameter : 8.425 in.

USC Units

Size	Connections ASME Flanges		Maximum Set Pressure (Psig)				Outlet Pressure Limit at 100°F (Psig)		Standard Materials	
	Inlet	Outlet	-20°F ~ 100°F	450°F	800°F	1000°F	Conventional	Bellows	Body / Bonnet	Spring
12 × 16	150	150	154	154			30	30	Carbon Steel	Carbon Steel
12 × 16	300	150	300	300			100	100		
12 × 16	150	150			154	154	30	30	Chrome Molybdenm Steel	High Temp Alloy Steel
12 × 16	300	150			154	154	30	30		

Metric Units

Size	Connections ASME Flanges		Maximum Set Pressure (Barg)				Outlet Pressure Limit at 38°C (Barg)		Standard Materials	
	Inlet	Outlet	-29°C ~ 38°C	232°C	426°C	537°C	Conventional	Bellows	Body / Bonnet	Spring
12 × 16	150	150	10.6	10.6			2.0	2.0	Carbon Steel	Carbon Steel
12 × 16	300	150	20.6	20.6			6.8	6.8		
12 × 16	150	150			10.6	10.6	2.0	2.0	Chrome Molybdenm Steel	High Temp Alloy Steel
12 × 16	300	150			10.6	10.6	2.0	2.0		

Y orifice

Area : 76.078 sq. in.
Diameter : 9.842 in.

USC Units

Size	Connections ASME Flanges		Maximum Set Pressure (Psig)				Outlet Pressure Limit at 100°F (Psig)		Standard Materials	
	Inlet	Outlet	-20°F ~ 100°F	450°F	800°F	1000°F	Conventional	Bellows	Body / Bonnet	Spring
14 × 18	150	150	154	154			30	30	Carbon Steel	Carbon Steel
14 × 18	300	150	300	300			100	100		
14 × 18	150	150			154	154	30	30	Chrome Molybdenm Steel	High Temp Alloy Steel
14 × 18	300	150			154	154	30	30		

Metric Units

Size	Connections ASME Flanges		Maximum Set Pressure (Barg)				Outlet Pressure Limit at 38°C (Barg)		Standard Materials	
	Inlet	Outlet	-29°C ~ 38°C	232°C	426°C	537°C	Conventional	Bellows	Body / Bonnet	Spring
14 × 18	150	150	10.6	10.6			2.0	2.0	Carbon Steel	Carbon Steel
14 × 18	300	150	20.6	20.6			6.8	6.8		
14 × 18	150	150			10.6	10.6	2.0	2.0	Chrome Molybdenm Steel	High Temp Alloy Steel
14 × 18	300	150			10.6	10.6	2.0	2.0		

10 Valve Sizing



Introduction :

▶ API Sizing

API establishes rules for sizing of pressure relief devices in the standard API STD 520. This standard addresses only flanged spring loaded and pilot operated safety relief valves with a D-T orifice. Valves smaller or larger than those with a D-T orifice are not addressed by API STD 520.

The API rules are generic for pressure relief devices, and API recognizes that Manufacturers of pressure relief devices may have criteria such as discharge coefficients and correction factors that differ from those listed in API STD 520. The API STD 520 equations and rules are intended for the estimation of pressure relief device requirements only. Final selection of the pressure relief device is accomplished by using the Manufacturer's specific parameters, which are based on actual testing.

It is traditional to size and select pressure relief valves specified per API STD 526 for gas, vapor and steam applications using the API STD 520 Kd value of 0.975 and the effective areas of API STD 526. Although the API Kd values exceed the ASME certified K values, the ASME certified areas exceed the effective areas of API STD 526 with the product of the ASME certified K and area exceeding the product of the API STD 520 Kd and API STD 526 effective areas.

▶ Flow Coefficient K(Coefficient of Discharge)

The K value has been established at the time valves are certified by ASME and are published for all ASME certified valves in "Pressure Relief Device certificates" by the National Board of Boiler and Pressure Vessel Inspectors, 1055 Crupper Ave., Columbus, Ohio 43229-1183.

Relating to sizing, API STD 526 details an effective discharge area.

▶ ASME Capacity Calculation

ASME codes establish the certified relieving capacities and corresponding media, which must be stamped on the valve name plates.

▶ Computer Sizing Program Information

JOKWANG Measurement has a computer sizing program which performs sizing and selection functions. Additionally, it will select materials, configure the complete value and provide a data sheet with a certified drawing including dimensions, weights, and materials.

Formula Symbols :

Prior to sizing Safety Relief Valves, the user should understand the symbols used in the sizing and capacity calculation formulas.

▶ **A** The safety relief valve area required to prevent the vessel or system pressure from exceeding prescribed limits above the vessel or system MAWP. The units used are USC(in^2) and Metric(mm^2).

▶ **C** Dimensionless, whole number valve determined from an expression of the ratio of specific heats of the gas or vapor.

▶ **k** Dimensionless ratio of the constant pressure specific heat C_p to the constant volume specific heat C_v .

▶ **K** Flow Coefficient($K_d \times 0.9$). Select the valve

based on valve type and type of media(refer the sizing formulas for proper valves.)

▶ **Kb** Dimensionless valve used to correct for the reduction in the safety relief valve capacity due to the effects of back pressure on conventional and balanced bellows valves

▶ **Kc** Pressure relief valve - rupture disk combination capacity factor.

▶ **Kd** Dimensionless valve relating the actual vs. theoretical safety relief valve flow rate. Select the

valve based on valve type and type of media(refer to sizing formulas for proper valves.)

▶ **K_{SH}** Dimensionless valve to correct for superheated system. For saturated steam Ksh=1.0

▶ **K_v** Dimensionless valve used to correct for the reduction in the safety relief valve capacity due to viscosity effects for liquid applications.

▶ **K_u** Dimensionless factor used to adjust for the type of units used in the sizing equation.

▶ **K_w** Dimensionless valve used to correct for the reduction in the safety relief valve capacity due to back pressure for balanced bellows valves(only when used on liquid applications)

▶ **M** Molecular Weight of the gas or vapor.

▶ **MAWP** Maximum Allowable Working Pressure.

▶ **P** The set pressure of the safety relief valve in gauge pressure units.

▶ **P_b** The pressure at the outlet of the valve in gauge pressure units.

▶ **P₁** The rated flowing pressure at the inlet of the safety relief valve in absolute pressure units(psia). This valve is the stamped set pressure of the safety relief valve plus the overpressure plus the atmospheric pressure. Refer to the section "Set Pressure and Overpressure Relationships for Sizing"

▶ **P₂** The pressure at the outlet of the valve in absolute pressure units(psia).

▶ **Q** Capacity in volume per time units.

▶ **R** Reynolds number. A dimensionless number used in obtaining the viscosity correction factor K_v.

▶ **p** Density of gas or vapor :

p, for vapors = (SG) x (Density of Air)

p, for liquid = (SG) x (Density of Water)

Density of Air = 0.0763 lb/ft³ at 14.7psia, and 60°F

Density of Air = 1.2932kg/m³ at 760mmHg and 0°C

Density of Water = 62.305 lb/ft³ at 70°F

Density of Water = 998kg/m³ at 20°C

▶ **G** Specific Gravity. A dimensionless number that relates the densities of a fluid to that of a standard fluid. The valve of SG is 1.0 for the following standard conditions:

- Liquid Standard: Water at 70°F

- Water at 20°C

- Gas standard: Air at 14.696 psia and 60°F

- Air at 760mmHg and 0°C

▶ **T** The temperature at the inlet of the valve in absolute temperature units. This valve is coincident with the rated flowing pressure valve, for example °F+460.

▶ **W** Capacity in Mass Per Time Units.

▶ **Z** Compressibility factor for gas or vapor. If unknown, use Z=1.

▶ **K_N** Napier Factor. A dimensionless correction factor to the Napier stream flow equation used only for steam and only in the range of P₁ = 1501 to 3200 psia flowing pressure. Calculate K_N from the equation:

If P₁ is 1500 psia or less, K_N = 1.0. If P₁ is more than 1500 psig, up to and including 3200 psia, K_N is calculated. Note that P₁ is the flowing pressure and is in absolute pressure units.

$$K_N = \frac{0.1906P_1 - 1000}{0.2292P_1 - 1061}$$

▶ Set Pressure and Overpressure Relationships for Sizing

Set pressure and overpressure requirements vary with the installation and application of the pressure relief valve(s). The installation may require one or more pressure relief valves per ASME Section VIII and API STD 520. The application will require the pressure relief valve(s) to provide overpressure protection caused by non-fire or fire-related events.

In all cases the overpressure of the pressure relief valve will be the difference between the accumulation of the system and the pressure relief valve's set pressure. In determining the required pressure relief valve



orifice area, the flowing pressure value (P1) will be equal to the system accumulation value.

Single Valve Installations

Used when only one pressure relief valve is required for system overpressure protection.

- 1 If the overpressure is not due to a fire exposure event :
 - a) The set pressure may be equal to or less than the MAWP of the protected system.
 - b) The accumulation of the system must not exceed the larger of 3 psi or 10% above the MAWP(see Table 1.)
- 2 If the overpressure is due to a fire exposure event on a vessel :
 - a) The set pressure may be equal to or less than the MAWP of the protected system.
 - b) The accumulation of the system must not exceed 21% above MAWP(see Table 2.)

Multiple Valve Installations

Applies when more than one pressure relief valve is required for system overpressure protection.

- 1 If the overpressure is not due to a fire exposure event :
 - a) The set pressure of at least one valve must be equal to or less than the MAWP of the protected system. The set pressure of any of the remaining valve(s) must not exceed 1.05 times the MAWP.
 - b) The accumulation of the system must not exceed the larger of 4 psi or 16% above the MAWP(see Table 3.)
- 1 If the overpressure is due to a fire exposure event on a vessel :
 - a) The set pressure of at least one valve must be equal to or less than the MAWP of the protected system. The set pressure of any of the remaining valve(s) must not exceed 1.10 times the MAWP.
 - b) The accumulation of the system must not exceed 21% above MAWP(see Table 2.)

Set Pressure and Overpressure Relationships for Sizing

Table 1 – Flowing Pressure for Single Valve Installations

MAWP of 15 psig to 30 psig	$P1 = MAWP + 3 + 14.7$
MAWP of 1.02 barg up to and including 2.06 barg	$P1 = MAWP + 0.206 + 1.01$
MAWP of 1.05kg/cm ² g up to and including 2.11kg/cm ² g	$P1 = MAWP + 0.211 + 1.03$
MAWP higher than 30 psig	$P1 = 1.1(MAWP) + 14.7$
MAWP higher than 2.06 barg	$P1 = 1.1(MAWP) + 1.01$
MAWP higher than 2.11kg/cm ² g	$P1 = 1.1(MAWP) + 1.03$

Table 2 – Flowing Pressure for FireSizing

MAWP higher than 15 psig	$P1 = 1.21(MAWP) + 14.7$
MAWP higher than 1.02 barg	$P1 = 1.21(MAWP) + 1.01$
MAWP higher than 1.05kg/cm ² g	$P1 = 1.21(MAWP) + 1.03$

Table 3 – Flowing Pressure for Multiple Valve Installations

MAWP of 15 psig to 25 psig	$P1 = MAWP + 4 + 14.7$
MAWP of 1.02 barg up to and including 1.72 barg	$P1 = MAWP + 0.275 + 1.01$
MAWP of 1.05kg/cm ² g up to and including 1.75kg/cm ² g	$P1 = MAWP + 0.281 + 1.03$
MAWP higher than 25 psig	$P1 = 1.16(MAWP) + 14.7$
MAWP higher than 1.72 barg	$P1 = 1.16(MAWP) + 1.01$
MAWP higher than 1.75kg/cm ² g	$P1 = 1.16(MAWP) + 1.03$

ASME SEC VIII Sizing Formula

	USC Units	Metric Units
Steam	$A1 = \frac{W1}{51.5 * Kd * P * KSH * KN * Kc}$	$A1 = \frac{W1}{5.25 * Kd * P * KSH * KN * Kc}$
Air	$A1 = \frac{W1}{356 * Kd * P * Kc} * \frac{\sqrt{T}}{\sqrt{M}}$	$A1 = \frac{W1}{27.03 * Kd * P * Kc} * \frac{\sqrt{T}}{\sqrt{M}}$
Gas	$A1 = \frac{W1}{C * Kd * P * Kc} * \frac{\sqrt{T * Z}}{\sqrt{M}}$	$A1 = \frac{W1}{C * Kd * P * Kc} * \frac{\sqrt{T * Z}}{\sqrt{M}}$
Liquid	$A1 = \frac{W1}{2407 * Kd * Kc * \sqrt{G * (P - Pb)}}$	$A1 = \frac{W1}{154.44 * Kd * Kc * \sqrt{G * (P - Pb)}}$

▶ **A1** Calculated area, (Required effective discharge area), in²(cm² for Liq / mm² for Gas)

▶ **A** Selected Area, (Actual discharge area), in²(cm² for Liq / mm² for Gas)

▶ **W1** Required capacity, lb/hr(kg/hr)

▶ **W** Valve Capacity(Kg/hr), lb/hr(kg/hr)

▶ **Kd** Coefficient of Discharge, 0.831(steam,vapor,gas), 0.615(liquid)

▶ **P** Relieving pressure, Psia(kgf /cm² for Liq / Mpa for Gas)

▶ **KSH** Superheat steam correction factor

▶ **Kc** Correction factor for a rupture disk

▶ **T** Relieving temperature of the inlet gas or vapor(K)

▶ **Z** Compressibility factor

▶ **C** Coefficient based on the Ratio of Specific Heat

▶ **M** Molecular weight

▶ **G** Specific gravity

▶ **Pb** Total back pressure, Psia(kgf /cm²g for Liq / Mpag for Gas)

▶ **KN** Correction factor for Napier equation

* Unit : USC(Metric)



API STD 520 Sizing Formula

	USC Units	Metric Units
Steam	$A1 = \frac{W1}{51.5 * Kd * P1 * Kb * KSH * KN * Kc}$	$A1 = \frac{190.5 * W1}{Kd * P1 * Kb * KSH * KN * Kc}$
Gas	$A1 = \frac{W1}{C * Kd * P1 * Kb * Kc} * \frac{\sqrt{T * Z}}{\sqrt{M}}$	$A1 = \frac{W1}{C * Kd * P1 * Kb * Kc} * \frac{\sqrt{T * Z}}{\sqrt{M}}$
Liquid	$A1 = \frac{W1}{38 * Kd * Kw * Kc * Kv} * \sqrt{\frac{G1}{P1 - P2}}$	$A1 = \frac{11.78 * W1}{Kd * Kw * Kc * Kv} * \sqrt{\frac{G1}{P1 - P2}}$

- ▶ **A1** Calculated area (Required effective discharge selected area), in²(mm²)
- ▶ **A** Selected Area (Actual discharge area), in²(mm²)
- ▶ **W1** Required capacity, lb/hr(kg/hr)
- ▶ **W** Valve Capacity, lb/hr(kg/hr)
- ▶ **Kd** Coefficient of Discharge ,0.831(steam, gas),0.615(liquid)
- ▶ **P1** Relieving pressure, Psia(kPa) for steam, gas/Psig(kPa) for liquid
- ▶ **Kb** Correction factor due to back pressure
- ▶ **Kc** Correction factor for a rupture disk
- ▶ **KN** Correction factor for Napier equation
- ▶ **KSH** Superheat steam correction factor
- ▶ **T** Relieving temperature of the inlet gas or vapor(K)
- ▶ **Z** Compressibility factor
- ▶ **C** Coefficient based on the Ratio of Specific Heat
- ▶ **M** Molecular weight
- ▶ **G1** Specific gravity
- ▶ **Pb** Total back pressure, Psia(kPa)
- ▶ **Kw** Correction factor due to back pressure
- ▶ **Kv** Correction factor due to viscosity
- ▶ **Kp** Correction factor due to overpressure
- ▶ **P2** Total back pressure, Psia(kPa)

* Unit : USC(Metric)

Capacity Table

ASME SEC VIII Steam Capacity Capacity for steam (Kg/h with 10% overpressure) : $W = 5.25 * A * K_d * K_c * P * K_{SH} * K_N$

set pressure Kg/cm ² (Mpag)	ORIFICE LETTER AND									
	D 70.97	E 126.45	F 198.71	G 326.45	H 506.45	J 834.19	K 1187.74	L 1846.45	M 2325.16	
1 (0.1)	65	116	182	299	464	764	1,088	1,692	2,130	
2 (0.2)	99	177	277	456	707	1,165	1,658	2,578	3,246	
3 (0.29)	130	231	363	597	926	1,525	2,171	3,375	4,250	
4 (0.39)	164	292	459	753	1,169	1,925	2,741	4,261	5,366	
5 (0.49)	198	353	554	910	1,412	2,326	3,311	5,148	6,482	
6 (0.59)	232	413	649	1,067	1,655	2,726	3,881	6,034	7,598	
7 (0.69)	266	474	745	1,223	1,898	3,126	4,451	6,920	8,714	
8 (0.78)	297	528	831	1,364	2,117	3,487	4,964	7,717	9,718	
9 (0.88)	331	589	926	1,521	2,360	3,887	5,534	8,603	10,834	
10 (0.98)	365	650	1,021	1,678	2,603	4,287	6,104	9,489	11,950	
11 (1.08)	399	711	1,117	1,834	2,846	4,687	6,674	10,376	13,066	
12 (1.18)	433	771	1,212	1,991	3,089	5,088	7,244	11,262	14,181	
13 (1.27)	464	826	1,298	2,132	3,308	5,448	7,757	12,059	15,186	
14 (1.37)	498	887	1,393	2,289	3,551	5,848	8,327	12,945	16,302	
15 (1.47)	532	947	1,489	2,445	3,794	6,249	8,897	13,831	17,417	
16 (1.57)	566	1,008	1,584	2,602	4,037	6,649	9,467	14,718	18,533	
17 (1.67)	600	1,069	1,679	2,759	4,280	7,049	10,037	15,604	19,649	
18 (1.76)	630	1,123	1,765	2,900	4,499	7,410	10,550	16,401	20,653	
19 (1.86)	664	1,184	1,860	3,056	4,742	7,810	11,120	17,287	21,769	
20 (1.96)	699	1,245	1,956	3,213	4,985	8,210	11,690	18,173	22,885	
22 (2.16)	767	1,366	2,146	3,526	5,471	9,011	12,830	19,946	25,117	
24 (2.35)	831	1,481	2,328	3,824	5,933	9,772	13,913	21,629	27,237	
26 (2.55)	899	1,603	2,518	4,137	6,419	10,572	15,053	23,402	29,469	
28 (2.74)	964	1,718	2,700	4,435	6,880	11,333	16,136	25,085	31,589	
30 (2.94)	1,032	1,839	2,890	4,748	7,367	12,134	17,276	26,857	33,820	
32 (3.14)	1,100	1,961	3,081	5,062	7,853	12,934	18,416	28,630	36,052	
34 (3.33)	1,165	2,076	3,262	5,359	8,314	13,695	19,499	30,313	38,172	
36 (3.53)	1,233	2,197	3,453	5,673	8,800	14,496	20,639	32,085	40,404	
38 (3.72)	1,298	2,313	3,634	5,970	9,262	15,256	21,722	33,769	42,524	
40 (3.92)	1,366	2,434	3,825	6,284	9,748	16,057	22,862	35,541	44,756	
42 (4.12)	1,434	2,555	4,016	6,597	10,234	16,858	24,002	37,314	46,987	
44 (4.31)	1,499	2,671	4,197	6,895	10,696	17,618	25,085	38,997	49,108	
46 (4.51)	1,567	2,792	4,387	7,208	11,182	18,419	26,225	40,769	51,339	
48 (4.7)	1,632	2,907	4,569	7,506	11,644	19,179	27,308	42,453	53,459	
50 (4.9)	1,700	3,029	4,759	7,819	12,130	19,980	28,448	44,225	55,691	
55 (5.39)	1,867	3,326	5,227	8,587	13,321	21,942	31,241	48,567	61,159	
60 (5.88)	2,034	3,623	5,694	9,354	14,512	23,903	34,034	52,909	66,626	
65 (6.37)	2,201	3,921	6,161	10,122	15,703	25,865	36,827	57,251	72,094	
70 (6.86)	2,367	4,218	6,628	10,890	16,894	27,827	39,620	61,593	77,562	
75 (7.35)	2,534	4,515	7,096	11,657	18,085	29,788	42,413	65,935	83,029	
80 (7.84)	2,701	4,813	7,563	12,425	19,276	31,750	45,206	70,277		
85 (8.33)	2,868	5,110	8,030	13,193	20,467	33,711	47,999	74,619		
90 (8.82)	3,035	5,407	8,498	13,960	21,658	35,673	50,792	78,961		
95 (9.31)	3,202	5,705	8,965	14,728	22,849	37,635	53,585	83,303		
100 (9.8)	3,369	6,002	9,432	15,496	24,040	39,596	56,378	87,645		
105 (10.29)	3,536	6,300	9,899	16,263	25,230	41,558	59,171	91,987		
110 (10.78)	3,702	6,597	10,367	17,031	26,421	43,519	61,964			
115 (11.27)	3,869	6,894	10,834	17,798	27,612	45,481	64,757			
120 (11.76)	4,036	7,192	11,301	18,566	28,803	47,443	67,550			
125 (12.25)	4,203	7,489	11,768	19,334	29,994	49,404	70,343			
130 (12.74)	4,370	7,786	12,236	20,101	31,185	51,366	73,136			
135 (13.23)	4,537	8,084	12,703	20,869	32,376	53,328	75,929			
140 (13.72)	4,704	8,381	13,170	21,637	33,567	55,289	78,722			
145 (14.21)	4,871	8,678	13,638	22,404	34,758	57,251				
150 (14.7)	5,038	8,976	14,105	23,172	35,949	59,212				
155 (15.19)	5,204	9,273	14,572	23,940	37,140	61,174				
160 (15.68)	5,371	9,570	15,039	24,707	38,331	63,136				
165 (16.17)	5,538	9,868	15,507	25,475	39,522	65,097				
170 (16.66)	5,705	10,165	15,974	26,243	40,713	67,059				
175 (17.15)	5,872	10,462	16,441	27,010	41,903	69,021				
180 (17.64)	6,039	10,760	16,908	27,778						
183 (17.93)	6,138	10,936	17,185	28,232						
186 (18.23)	6,240	11,118	17,471	28,702						
189 (18.52)	6,339	11,294	17,748	29,157						
192 (18.82)	6,441	11,476	18,034	29,627						
195 (19.11)	6,540	11,652	18,310	30,081						
198 (19.4)	6,638	11,828	18,587	30,535						
201 (19.7)	6,741	12,010	18,873	31,005						
203 (19.89)	6,805	12,125	19,054	31,303						



Metric Units

EFFECTIVE AREA (mm ²)									set pressure Kg/cm ² (Mpag)
N	P	Q	R	T	V	W	Y		
2798.06	4115.48	7132.89	10334.17	16787.71	25449.63	35966.38	49082.48	1 (0.1)	
2,564	3,771	6,535	9,468	15,381	23,316	32,952	44,968	2 (0.2)	
3,906	5,746	9,958	14,427	23,437	35,530	50,212	68,523	3 (0.29)	
5,115	7,523	13,039	18,891	30,688	46,522	65,746	89,722	4 (0.39)	
6,458	9,498	16,462	23,850	38,744	58,735	83,007	113,277	5 (0.49)	
7,800	11,473	19,885	28,810	46,801	70,948	100,267	136,832	6 (0.59)	
9,143	13,448	23,308	33,769	54,857	83,162	117,527	160,387	7 (0.69)	
10,486	15,423	26,731	38,728	62,914	95,375	134,788	183,942	8 (0.78)	
11,695	17,201	29,812	43,192	70,164	106,367	150,322	205,141	9 (0.88)	
13,037	19,176	33,235	48,151	78,221	118,580	167,582	228,696	10 (0.98)	
14,380	21,151	36,658	53,111	86,277	130,794	184,843	252,251	11 (1.08)	
15,723	23,126	40,081	58,070	94,334	143,007	202,103	275,805	12 (1.18)	
17,066	25,101	43,504	63,029	102,390	155,220	219,363	299,360	13 (1.27)	
18,274	26,878	46,585	67,493	109,641	166,212	234,898	320,559	14 (1.37)	
19,617	28,853	50,008	72,452	117,698	178,426	252,158	344,114	15 (1.47)	
20,960	30,828	53,431	77,412	125,754	190,639	269,418	367,669	16 (1.57)	
22,303	32,803	56,854	82,371	133,811	202,852	286,679	391,224	17 (1.67)	
23,645	34,778	60,278	87,330	141,867	215,066	303,939	414,779	18 (1.76)	
24,854	36,556	63,358	91,794	149,118	226,058	319,473	435,978	19 (1.86)	
26,197	38,531	66,781	96,753	157,174	238,271	336,734	459,533	20 (1.96)	
27,540	40,506	70,204	101,713	165,231	250,485	353,994	483,088	22 (2.16)	
30,225	44,456	77,051						24 (2.35)	
32,776	48,209	83,555						26 (2.55)	
35,462	52,159	90,401						28 (2.74)	
38,013	55,911	96,905						30 (2.94)	
40,699	59,861	103,751						32 (3.14)	
43,385	63,811	110,597						34 (3.33)	
45,936	67,564	117,101						36 (3.53)	
48,621	71,514	123,947						38 (3.72)	
51,173	75,267	130,451						40 (3.92)	
53,858	79,217	137,297						42 (4.12)	
56,544	83,167	144,143						44 (4.31)	
59,095	86,919							46 (4.51)	
61,781	90,869							48 (4.7)	
64,332	94,622							50 (4.9)	
67,018	98,572							55 (5.39)	
73,597	108,250							60 (5.88)	
80,177	117,927							65 (6.37)	
86,757	127,605							70 (6.86)	
93,337	137,282							75 (7.35)	
								80 (7.84)	
								85 (8.33)	
								90 (8.82)	
								95 (9.31)	
								100 (9.8)	
								105 (10.29)	
								110 (10.78)	
								115 (11.27)	
								120 (11.76)	
								125 (12.25)	
								130 (12.74)	
								135 (13.23)	
								140 (13.72)	
								145 (14.21)	
								150 (14.7)	
								155 (15.19)	
								160 (15.68)	
								165 (16.17)	
								170 (16.66)	
								175 (17.15)	
								180 (17.64)	
								183 (17.93)	
								186 (18.23)	
								189 (18.52)	
								192 (18.82)	
								195 (19.11)	
								198 (19.4)	
								201 (19.7)	
								203 (19.89)	

* For units : $W = 51.5 * A * Kd * Kc * P * KSH * KN$

ASME SEC VIII Air Capacity

Capacity for air (Kg/h at 20°C with 10% overpressure) : $W = 27.03 * A * K_d * P * K_c * \sqrt{\frac{M}{T}}$

set pressure Kg/cm ² g(Mpag)	ORIFICE LETTER AND									
	D 70.97	E 126.45	F 198.71	G 326.45	H 506.45	J 834.19	K 1187.74	L 1846.45	M 2325.16	
1 (0.1)	105	188	295	484	751	1,237	1,761	2,738	3,448	
2 (0.2)	160	286	449	738	1,144	1,885	2,684	4,173	5,254	
3 (0.3)	210	374	588	966	1,499	2,468	3,514	5,463	6,880	
4 (0.4)	265	472	742	1,220	1,892	3,116	4,437	6,898	8,686	
5 (0.5)	320	571	897	1,473	2,285	3,764	5,360	8,332	10,492	
6 (0.6)	375	669	1,051	1,727	2,679	4,412	6,282	9,766	12,298	
7 (0.7)	431	767	1,205	1,980	3,072	5,060	7,205	11,201	14,105	
8 (0.8)	480	855	1,344	2,208	3,426	5,643	8,035	12,492	15,730	
9 (0.9)	535	954	1,499	2,462	3,820	6,291	8,958	13,926	17,536	
10 (1)	590	1,052	1,653	2,716	4,213	6,939	9,881	15,360	19,342	
11 (1.1)	646	1,150	1,807	2,969	4,606	7,587	10,803	16,794	21,149	
12 (1.2)	701	1,248	1,962	3,223	5,000	8,235	11,726	18,229	22,955	
13 (1.3)	750	1,337	2,101	3,451	5,354	8,819	12,556	19,520	24,580	
14 (1.4)	805	1,435	2,255	3,705	5,747	9,467	13,479	20,954	26,386	
15 (1.5)	861	1,533	2,409	3,958	6,141	10,115	14,401	22,388	28,193	
16 (1.6)	916	1,631	2,564	4,212	6,534	10,763	15,324	23,823	29,999	
17 (1.7)	971	1,730	2,718	4,465	6,928	11,411	16,247	25,257	31,805	
18 (1.8)	1,020	1,818	2,857	4,694	7,282	11,994	17,077	26,548	33,431	
19 (1.9)	1,076	1,916	3,011	4,947	7,675	12,642	18,000	27,982	35,237	
20 (2)	1,131	2,015	3,166	5,201	8,068	13,290	18,922	29,416	37,043	
21 (2.1)	1,186	2,113	3,320	5,454	8,462	13,938	19,845	30,851	38,849	
22 (2.2)	1,241	2,211	3,474	5,708	8,855	14,586	20,768	32,285	40,655	
23 (2.3)	1,291	2,299	3,613	5,936	9,209	15,169	21,598	33,576	42,281	
24 (2.4)	1,346	2,398	3,768	6,190	9,603	15,817	22,521	35,010	44,087	
25 (2.5)	1,401	2,496	3,922	6,443	9,996	16,465	23,443	36,444	45,893	
26 (2.6)	1,456	2,594	4,076	6,697	10,390	17,113	24,366	37,879	47,699	
27 (2.7)	1,511	2,692	4,231	6,951	10,783	17,761	25,288	39,313	49,505	
28 (2.8)	1,561	2,781	4,370	7,179	11,137	18,344	26,119	40,604	51,131	
29 (2.9)	1,616	2,879	4,524	7,432	11,530	18,992	27,041	42,038	52,937	
30 (3)	1,671	2,977	4,678	7,686	11,924	19,640	27,964	43,473	54,743	
40 (4)	2,211	3,940	6,191	10,171	15,779	25,990	37,006	57,529	72,444	
50 (5)	2,751	4,902	7,704	12,656	19,635	32,341	46,048	71,585	90,144	
60 (6)	3,292	5,865	9,216	15,141	23,490	38,691	55,089	85,641	107,845	
70 (7)	3,832	6,828	10,729	17,626	27,345	45,041	64,131	99,698	125,545	
80 (8)	4,372	7,790	12,242	20,112	31,201	51,392	73,173	113,754		
90 (9)	4,912	8,753	13,755	22,597	35,056	57,742	82,215	127,810		
100 (10)	5,453	9,715	15,267	25,082	38,912	64,092	91,256	141,866		
110 (11)	5,993	10,678	16,780	27,567	42,767	70,443	100,298			
120 (12)	6,533	11,641	18,293	30,052	46,622	76,793	109,340			
130 (13)	7,074	12,603	19,805	32,537	50,478	83,143	118,382			
140 (14)	7,614	13,566	21,318	35,022	54,333	89,494	127,423			
150 (15)	8,154	14,528	22,831	37,507	58,188	95,844	136,465			
160 (16)	8,694	15,491	24,343	39,993	62,044	102,194				
170 (17)	9,235	16,454	25,856	42,478	65,899	108,545				
180 (18)	9,775	17,416	27,369	44,963	69,755	114,895				
190 (19)	10,315	18,379	28,882	47,448	73,610					
200 (20)	10,855	19,341	30,394	49,933						
210 (21)	11,396	20,304	31,907	52,418						
220 (22)	11,936	21,267	33,420	54,903						
230 (23)	12,476	22,229	34,932	57,388						
240 (24)	13,016	23,192	36,445	59,873						
250 (25)	13,557	24,155	37,958	62,359						
260 (26)	14,097	25,117	39,470	64,844						
270 (27)	14,637	26,080	40,983							
280 (28)	15,178	27,042	42,496							
290 (29)	15,718	28,005	44,008							
300 (30)	16,258	28,968	45,521							
310 (31)	16,798	29,930	47,034							
320 (32)	17,339	30,893	48,547							
330 (33)	17,879	31,855	50,059							
340 (34)	18,419	32,818	51,572							
350 (35)	18,959	33,781	53,085							
360 (36)	19,500	34,743								
370 (37)	20,040	35,706								
380 (38)	20,580	36,668								
390 (39)	21,120	37,631								
400 (40)	21,661	38,594								
410 (41)	22,201	39,556								
420 (42)	22,741	40,519								

Capacity Table



Metric units

EFFECTIVE AREA (mm ²)									set pressure Kg/cm ² (Mpag)
N	P	Q	R	T	V	W	Y		
2798.06	4115.48	7132.89	10334.17	16787.71	25449.63	35966.38	49082.48		
4,149	6,103	10,578	15,325	24,896	37,741	53,337	72,788	1	(0.1)
6,323	9,300	16,119	23,353	37,936	57,510	81,275	110,915	2	(0.2)
8,279	12,177	21,105	30,578	49,673	75,302	106,420	145,229	3	(0.3)
10,453	15,374	26,646	38,605	62,713	95,071	134,358	183,356	4	(0.4)
12,626	18,571	32,187	46,633	75,754	114,840	162,297	221,483	5	(0.5)
14,800	21,768	37,728	54,660	88,794	134,610	190,235	259,610	6	(0.6)
16,973	24,965	43,268	62,688	101,835	154,379	218,174	297,737	7	(0.7)
18,929	27,842	48,255	69,912	113,572	172,171	243,318	332,051	8	(0.8)
21,103	31,039	53,796	77,940	126,612	191,940	271,257	370,178	9	(0.9)
23,276	34,236	59,337	85,967	139,653	211,709	299,195	408,305	10	(1)
25,450	37,433	64,877	93,995	152,693	231,478	327,134	446,432	11	(1.1)
27,623	40,629	70,418	102,022	165,734	251,247	355,072	484,558	12	(1.2)
29,580	43,507	75,405	109,247	177,470	269,039	380,217	518,873	13	(1.3)
31,753	46,703	80,946	117,275	190,511	288,808	408,155	557,000	14	(1.4)
33,927	49,900	86,487	125,302	203,551	308,578	436,093	595,127	15	(1.5)
36,100	53,097	92,027	133,330	216,592	328,347	464,032	633,253	16	(1.6)
38,274	56,294	97,568	141,357	229,633	348,116	491,970	671,380	17	(1.7)
40,230	59,171	102,555	148,582	241,369	365,908	517,115	705,695	18	(1.8)
42,403	62,368	108,096	156,609	254,410	385,677	545,053	743,822	19	(1.9)
44,577	65,565	113,636	164,637	267,450	405,446	572,992	781,948	20	(2)
46,750	68,762	119,177	172,664	280,491	425,215	600,930	820,075	21	(2.1)
48,924	71,959	124,718						22	(2.2)
50,880	74,836	129,705						23	(2.3)
53,053	78,033	135,245						24	(2.4)
55,227	81,230	140,786						25	(2.5)
57,401	84,427	146,327						26	(2.6)
59,574	87,623	151,868						27	(2.7)
61,530	90,501	156,854						28	(2.8)
63,704	93,698	162,395						29	(2.9)
65,877	96,894	167,936						30	(3)
87,178	128,224	222,236						40	(4)
108,478	159,553							50	(5)
129,778	190,883							60	(6)
151,079	222,212							70	(7)
								80	(8)
								90	(9)
								100	(10)
								110	(11)
								120	(12)
								130	(13)
								140	(14)
								150	(15)
								160	(16)
								170	(17)
								180	(18)
								190	(19)
								200	(20)
								210	(21)
								220	(22)
								230	(23)
								240	(24)
								250	(25)
								260	(26)
								270	(27)
								280	(28)
								290	(29)
								300	(30)
								310	(31)
								320	(32)
								330	(33)
								340	(34)
								350	(35)
								360	(36)
								370	(37)
								380	(38)
								390	(39)
								400	(40)
								410	(41)
								420	(42)

* For USC units : $W = 356 * A * Kd * P * Kc * \sqrt{\frac{M}{T}}$

ASME SEC VIII Water Capacity Capacity for water (Kg/h with 10% overpressure) : $W = 159.44 * A * K_d * K_c * \sqrt{(P-P_b) * G}$

set pressure Kg/cm ² g(Mpag)	ORIFICE LETTER AND									
	D 0.71	E 1.26	F 1.99	G 3.26	H 5.06	J 8.34	K 11.88	L 18.46	M 23.25	
1 (0.1)	2,309	4,098	6,472	10,602	16,456	27,123	38,635	60,034	75,612	
2 (0.2)	3,265	5,795	9,152	14,993	23,272	38,357	54,639	84,902	106,932	
3 (0.3)	3,999	7,097	11,209	18,363	28,502	46,978	66,918	103,983	130,964	
4 (0.4)	4,618	8,195	12,944	21,204	32,912	54,246	77,271	120,069	151,224	
5 (0.5)	5,163	9,163	14,471	23,707	36,796	60,648	86,391	134,241	169,074	
6 (0.6)	5,656	10,037	15,852	25,969	40,308	66,437	94,637	147,054	185,211	
7 (0.7)	6,109	10,841	17,123	28,050	43,538	71,760	102,220	158,836	200,051	
8 (0.8)	6,531	11,590	18,305	29,987	46,544	76,715	109,277	169,803	213,864	
9 (0.9)	6,927	12,293	19,415	31,806	49,367	81,368	115,906	180,103	226,837	
10 (1)	7,302	12,958	20,465	33,526	52,038	85,770	122,176	189,846	239,107	
11 (1.1)	7,658	13,591	21,464	35,163	54,578	89,956	128,139	199,112	250,777	
12 (1.2)	7,999	14,195	22,419	36,726	57,005	93,956	133,837	207,965	261,928	
13 (1.3)	8,325	14,774	23,334	38,226	59,332	97,793	139,302	216,457	272,624	
14 (1.4)	8,640	15,332	24,215	39,669	61,572	101,484	144,560	224,628	282,915	
15 (1.5)	8,943	15,870	25,065	41,061	63,733	105,046	149,634	232,512	292,845	
16 (1.6)	9,236	16,391	25,887	42,408	65,823	108,491	154,542	240,138	302,449	
17 (1.7)	9,520	16,895	26,684	43,713	67,849	111,830	159,298	247,528	311,757	
18 (1.8)	9,796	17,385	27,457	44,980	69,816	115,072	163,916	254,705	320,795	
19 (1.9)	10,065	17,861	28,210	46,213	71,729	118,226	168,408	261,684	329,586	
20 (2)	10,326	18,325	28,943	47,413	73,593	121,297	172,783	268,482	338,148	
21 (2.1)	10,581	18,778	29,657	48,584	75,410	124,292	177,050	275,112	346,498	
22 (2.2)	10,830	19,220	30,355	49,728	77,185	127,217	181,216	281,586	354,653	
23 (2.3)	11,074	19,652	31,037	50,845	78,919	130,076	185,289	287,915	362,623	
24 (2.4)	11,312	20,075	31,705	51,939	80,617	132,874	189,274	294,107	370,422	
25 (2.5)	11,545	20,488	32,359	53,010	82,279	135,614	193,177	300,172	378,061	
26 (2.6)	11,774	20,894	33,000	54,060	83,908	138,300	197,003	306,117	385,548	
27 (2.7)	11,998	21,292	33,628	55,089	85,507	140,934	200,755	311,948	392,892	
28 (2.8)	12,218	21,683	34,245	56,100	87,076	143,520	204,439	317,672	400,102	
29 (2.9)	12,434	22,067	34,851	57,093	88,617	146,061	208,058	323,295	407,184	
30 (3)	12,647	22,444	35,447	58,069	90,132	148,558	211,615	328,822	414,145	
40 (4)	14,604	25,916	40,931	67,053	104,076	171,540	244,352	379,691	478,213	
50 (5)	16,327	28,975	45,762	74,967	116,360	191,787	273,193	424,508	534,659	
60 (6)	17,886	31,741	50,130	82,122	127,466	210,092	299,268	465,025	585,689	
70 (7)	19,319	34,284	54,147	88,702	137,679	226,926	323,247	502,284	632,617	
80 (8)	20,652	36,651	57,885	94,827	147,185	242,594	345,565	536,964		
90 (9)	21,905	38,874	61,396	100,579	156,114	257,310	366,527	569,537		
100 (10)	23,090	40,977	64,718	106,020	164,558	271,228	386,354	600,344		
110 (11)	24,217	42,977	67,876	111,194	172,590	284,467	405,211			
120 (12)	25,294	44,888	70,894	116,139	180,264	297,116	423,229			
130 (13)	26,327	46,721	73,789	120,881	187,625	309,248	440,511			
140 (14)	27,321	48,485	76,575	125,444	194,708	320,921	457,140			
150 (15)	28,280	50,186	79,262	129,847	201,542	332,185	473,185			
160 (16)	29,207	51,832	81,862	134,105	208,151	343,080				
170 (17)	30,106	53,427	84,381	138,233	214,558	353,638				
180 (18)	30,979	54,976	86,828	142,240	220,778	363,891				
190 (19)	31,828	56,483	89,207	146,138	226,828					
200 (20)	32,654	57,950	91,524	149,934						
210 (21)	33,461	59,381	93,785	153,637						
220 (22)	34,248	60,779	95,992	157,253						
230 (23)	35,018	62,145	98,149	160,787						
240 (24)	35,771	63,481	100,260	164,245						
250 (25)	36,509	64,790	102,327	167,632						
260 (26)	37,232	66,073	104,354	170,952						
270 (27)	37,941	67,332	106,342							
280 (28)	38,637	68,567	108,293							
290 (29)	39,321	69,781	110,210							
300 (30)	39,993	70,974	112,094							
310 (31)	40,654	72,147	113,947							
320 (32)	41,305	73,302	115,770							
330 (33)	41,945	74,438	117,565							
340 (34)	42,576	75,558	119,333							
350 (35)	43,198	76,661	121,075							
360 (36)	43,811	77,748								
370 (37)	44,415	78,821								
380 (38)	45,011	79,879								
390 (39)	45,599	80,923								
400 (40)	46,180	81,954								
410 (41)	46,754	82,972								
420 (42)	47,321	83,978								

Capacity Table



Metric units

EFFECTIVE AREA (cm ²)									set pressure Kg/cm ² (Mpag)
N	P	Q	R	T	V	W	Y		
27.98	41.15	71.33	103.34	167.88	254.5	359.66	490.82		
90,995	133,825	231,975	336,076	545,969	827,669	1,169,663	1,596,214	1	(0.1)
128,686	189,258	328,062	475,283	772,116	1,170,500	1,654,154	2,257,387	2	(0.2)
157,608	231,792	401,792	582,100	945,645	1,433,564	2,025,916	2,764,723	3	(0.3)
181,990	267,651	463,950	672,152	1,091,937	1,655,337	2,339,327	3,192,427	4	(0.4)
203,471	299,243	518,712	751,488	1,220,823	1,850,723	2,615,447	3,569,242	5	(0.5)
222,891	327,804	568,220	823,214	1,337,345	2,027,366	2,865,078	3,909,909	6	(0.6)
240,750	354,069	613,748	889,173	1,444,497	2,189,806	3,094,638	4,223,184	7	(0.7)
257,372	378,515	656,124	950,566	1,544,233	2,341,001	3,308,308	4,514,774	8	(0.8)
272,984	401,476	695,925	1,008,227	1,637,906	2,483,006	3,508,990	4,788,641	9	(0.9)
287,751	423,193	733,569	1,062,765	1,726,504	2,617,318	3,698,800	5,047,670	10	(1)
301,796	443,849	769,374	1,114,637	1,810,773	2,745,067	3,879,334	5,294,041	11	(1.1)
315,215	463,585	803,585	1,164,201	1,891,291	2,867,128	4,051,833	5,529,446	12	(1.2)
328,086	482,514	836,397	1,211,738	1,968,518	2,984,202	4,217,281	5,755,230	13	(1.3)
340,471	500,729	867,971	1,257,480	2,042,828	3,096,853	4,376,480	5,972,484	14	(1.4)
352,421	518,304	898,435	1,301,616	2,114,527	3,205,547	4,530,087	6,182,109	15	(1.5)
363,979	535,302	927,900	1,344,303	2,183,875	3,310,675	4,678,653	6,384,854	16	(1.6)
375,181	551,776	956,457	1,385,676	2,251,086	3,412,565	4,822,646	6,581,357	17	(1.7)
386,058	567,773	984,186	1,425,849	2,316,349	3,511,501	4,962,461	6,772,161	18	(1.8)
396,637	583,331	1,011,155	1,464,920	2,379,822	3,607,724	5,098,444	6,957,734	19	(1.9)
406,941	598,485	1,037,423	1,502,977	2,441,646	3,701,447	5,230,894	7,138,484	20	(2)
416,990	613,265	1,063,042	1,540,093	2,501,943	3,792,854	5,360,071	7,314,769	21	(2.1)
426,803	627,697	1,088,059						22	(2.2)
436,396	641,804	1,112,512						23	(2.3)
445,782	655,608	1,136,440						24	(2.4)
454,974	669,127	1,159,874						25	(2.5)
463,984	682,378	1,182,844						26	(2.6)
472,823	695,377	1,205,377						27	(2.7)
481,499	708,138	1,227,496						28	(2.8)
490,022	720,672	1,249,223						29	(2.9)
498,399	732,992	1,270,579						30	(3)
575,501	846,386	1,467,138						40	(4)
643,430	946,289							50	(5)
704,842	1,036,607							60	(6)
761,317	1,119,664							70	(7)
								80	(8)
								90	(9)
								100	(10)
								110	(11)
								120	(12)
								130	(13)
								140	(14)
								150	(15)
								160	(16)
								170	(17)
								180	(18)
								190	(19)
								200	(20)
								210	(21)
								220	(22)
								230	(23)
								240	(24)
								250	(25)
								260	(26)
								270	(27)
								280	(28)
								290	(29)
								300	(30)
								310	(31)
								320	(32)
								330	(33)
								340	(34)
								350	(35)
								360	(36)
								370	(37)
								380	(38)
								390	(39)
								400	(40)
								410	(41)
								420	(42)

* For USC units : $W = 2407 * A * Kd * Kc * \sqrt{(P-Pb)} * G$

API STD 520 Steam Capacity Capacity for steam (Kg/h with 10% overpressure) : $W = \frac{A * P_1 * K_d * K_b * K_c * K_N * K_{SH}}{190.5}$

set pressure Kg/cm ² (Mpag)	ORIFICE LETTER AND									
	D 70.97	E 126.45	F 198.71	G 326.45	H 506.45	J 834.19	K 1187.74	L 1846.45	M 2325.16	
1 (0.1)	65	115	181	298	462	761	1,084	1,685	2,122	
2 (0.2)	98	175	275	452	701	1,154	1,643	2,554	3,216	
3 (0.29)	132	234	368	605	939	1,546	2,202	3,423	4,310	
4 (0.39)	165	294	462	759	1,177	1,939	2,761	4,292	5,404	
5 (0.49)	198	353	555	912	1,415	2,331	3,319	5,160	6,498	
6 (0.59)	232	413	649	1,066	1,654	2,724	3,878	6,029	7,592	
7 (0.69)	265	472	742	1,220	1,892	3,116	4,437	6,898	8,686	
8 (0.78)	299	532	836	1,373	2,130	3,509	4,996	7,766	9,780	
9 (0.88)	332	591	929	1,527	2,368	3,901	5,555	8,635	10,874	
10 (0.98)	365	651	1,023	1,680	2,607	4,294	6,113	9,504	11,968	
11 (1.08)	399	710	1,116	1,834	2,845	4,686	6,672	10,373	13,062	
12 (1.18)	432	770	1,210	1,987	3,083	5,079	7,231	11,241	14,156	
13 (1.27)	465	829	1,303	2,141	3,322	5,471	7,790	12,110	15,250	
14 (1.37)	499	889	1,397	2,295	3,560	5,864	8,349	12,979	16,344	
15 (1.47)	532	948	1,490	2,448	3,798	6,256	8,908	13,848	17,438	
16 (1.57)	566	1,008	1,584	2,602	4,036	6,649	9,466	14,716	18,532	
17 (1.67)	599	1,067	1,677	2,755	4,275	7,041	10,025	15,585	19,626	
18 (1.76)	632	1,127	1,771	2,909	4,513	7,434	10,584	16,454	20,720	
19 (1.86)	666	1,186	1,864	3,063	4,751	7,826	11,143	17,323	21,814	
20 (1.96)	699	1,246	1,958	3,216	4,990	8,219	11,702	18,191	22,908	
22 (2.16)	766	1,365	2,145	3,523	5,466	9,003	12,819	19,929	25,096	
24 (2.35)	833	1,484	2,332	3,831	5,943	9,788	13,937	21,666	27,284	
26 (2.55)	900	1,603	2,519	4,138	6,419	10,573	15,055	23,404	29,471	
28 (2.74)	966	1,722	2,706	4,445	6,896	11,358	16,172	25,141	31,659	
30 (2.94)	1,033	1,841	2,893	4,752	7,372	12,143	17,290	26,879	33,847	
32 (3.14)	1,100	1,960	3,080	5,059	7,849	12,928	18,408	28,616	36,035	
34 (3.33)	1,167	2,079	3,267	5,367	8,326	13,713	19,525	30,354	38,223	
36 (3.53)	1,233	2,198	3,454	5,674	8,802	14,498	20,643	32,091	40,411	
38 (3.72)	1,300	2,317	3,641	5,981	9,279	15,283	21,761	33,829	42,599	
40 (3.92)	1,367	2,436	3,828	6,288	9,755	16,068	22,878	35,566	44,787	
42 (4.12)	1,434	2,555	4,015	6,595	10,232	16,853	23,996	37,304	46,975	
44 (4.31)	1,501	2,674	4,202	6,902	10,708	17,638	25,113	39,041	49,163	
46 (4.51)	1,567	2,793	4,388	7,210	11,185	18,423	26,231	40,779	51,351	
48 (4.7)	1,634	2,912	4,575	7,517	11,661	19,208	27,349	42,516	53,539	
50 (4.9)	1,701	3,031	4,762	7,824	12,138	19,993	28,466	44,254	55,727	
55 (5.39)	1,868	3,328	5,230	8,592	13,329	21,955	31,261	48,597	61,197	
60 (5.88)	2,035	3,626	5,697	9,360	14,521	23,918	34,055	52,941	66,667	
65 (6.37)	2,202	3,923	6,165	10,128	15,712	25,880	36,849	57,285	72,136	
70 (6.86)	2,369	4,220	6,632	10,896	16,904	27,843	39,643	61,628	77,606	
75 (7.35)	2,536	4,518	7,100	11,664	18,095	29,805	42,437	65,972	83,076	
80 (7.84)	2,703	4,815	7,567	12,432	19,286	31,767	45,231	70,316		
85 (8.33)	2,870	5,113	8,035	13,200	20,478	33,730	48,025	74,660		
90 (8.82)	3,037	5,410	8,502	13,968	21,669	35,692	50,819	79,003		
95 (9.31)	3,204	5,708	8,970	14,736	22,861	37,655	53,613	83,347		
100 (9.8)	3,370	6,005	9,437	15,504	24,052	39,617	56,408	87,691		
105 (10.29)	3,537	6,303	9,904	16,272	25,243	41,579	59,202	92,034		
110 (10.78)	3,704	6,600	10,372	17,040	26,435	43,542	61,996			
115 (11.27)	3,871	6,898	10,839	17,807	27,626	45,504	64,790			
120 (11.76)	4,038	7,195	11,307	18,575	28,818	47,467	67,584			
125 (12.25)	4,205	7,493	11,774	19,343	30,009	49,429	70,378			
130 (12.74)	4,372	7,790	12,242	20,111	31,200	51,391	73,172			
135 (13.23)	4,539	8,088	12,709	20,879	32,392	53,354	75,966			
140 (13.72)	4,706	8,385	13,177	21,647	33,583	55,316	78,760			
145 (14.21)	4,873	8,683	13,644	22,415	34,775	57,279				
150 (14.7)	5,040	8,980	14,112	23,183	35,966	59,241				
155 (15.19)	5,207	9,277	14,579	23,951	37,158	61,203				
160 (15.68)	5,374	9,575	15,047	24,719	38,349	63,166				
165 (16.17)	5,541	9,872	15,514	25,487	39,540	65,128				
170 (16.66)	5,708	10,170	15,981	26,255	40,732	67,091				
175 (17.15)	5,875	10,467	16,449	27,023	41,923	69,053				
180 (17.64)	6,042	10,765	16,916	27,791						
183 (17.93)	6,142	10,943	17,197	28,252						
186 (18.23)	6,242	11,122	17,477	28,713						
189 (18.52)	6,342	11,300	17,758	29,173						
192 (18.82)	6,442	11,479	18,038	29,634						
195 (19.11)	6,543	11,657	18,319	30,095						
198 (19.4)	6,643	11,836	18,599	30,556						
201 (19.7)	6,743	12,014	18,880	31,016						
203 (19.89)	6,810	12,133	19,067	31,324						

Capacity Table



Metric units

EFFECTIVE AREA (mm ²)									set pressure	
N	P	Q	R	T	V	W	Y		Kg/cm ²	(Mpag)
2798.06	4115.48	7132.89	10334.17	16787.71	25449.63	35966.38	49082.48		1	(0.1)
2,554	3,756	6,510	9,432	15,323	23,229	32,827	44,799		2	(0.2)
3,870	5,693	9,866	14,294	23,221	35,202	49,749	67,892		3	(0.29)
5,187	7,629	13,222	19,157	31,120	47,176	66,671	90,985		4	(0.39)
6,503	9,565	16,578	24,019	39,018	59,150	83,593	114,078		5	(0.49)
7,820	11,502	19,934	28,881	46,917	71,124	100,515	137,171		6	(0.59)
9,136	13,438	23,290	33,743	54,815	83,098	117,437	160,264		7	(0.69)
10,453	15,374	26,646	38,605	62,714	95,072	134,359	183,356		8	(0.78)
11,769	17,310	30,002	43,467	70,612	107,046	151,281	206,449		9	(0.88)
13,086	19,247	33,358	48,329	78,511	119,019	168,203	229,542		10	(0.98)
14,402	21,183	36,714	53,192	86,409	130,993	185,125	252,635		11	(1.08)
15,719	23,119	40,070	58,054	94,308	142,967	202,047	275,728		12	(1.18)
17,035	25,056	43,426	62,916	102,206	154,941	218,969	298,821		13	(1.27)
18,351	26,992	46,782	67,778	110,104	166,915	235,890	321,914		14	(1.37)
19,668	28,928	50,138	72,640	118,003	178,889	252,812	345,007		15	(1.47)
20,984	30,865	53,494	77,502	125,901	190,863	269,734	368,100		16	(1.57)
22,301	32,801	56,850	82,365	133,800	202,836	286,656	391,193		17	(1.67)
23,617	34,737	60,206	87,227	141,698	214,810	303,578	414,286		18	(1.76)
24,934	36,673	63,562	92,089	149,597	226,784	320,500	437,379		19	(1.86)
26,250	38,610	66,918	96,951	157,495	238,758	337,422	460,472		20	(1.96)
27,567	40,546	70,274	101,813	165,394	250,732	354,344	483,565		22	(2.16)
30,200	44,419	76,986							24	(2.35)
32,833	48,291	83,698							26	(2.55)
35,466	52,164	90,410							28	(2.74)
38,098	56,036	97,122							30	(2.94)
40,731	59,909	103,834							32	(3.14)
43,364	63,782	110,546							34	(3.33)
45,997	67,654	117,257							36	(3.53)
48,630	71,527	123,969							38	(3.72)
51,263	75,400	130,681							40	(3.92)
53,896	79,272	137,393							42	(4.12)
56,529	83,145	144,105							44	(4.31)
59,162	87,017								46	(4.51)
61,795	90,890								48	(4.7)
64,428	94,763								50	(4.9)
67,061	98,635								55	(5.39)
73,643	108,317								60	(5.88)
80,225	117,998								65	(6.37)
86,808	127,680								70	(6.86)
93,390	137,361								75	(7.35)
									80	(7.84)
									85	(8.33)
									90	(8.82)
									95	(9.31)
									100	(9.8)
									105	(10.29)
									110	(10.78)
									115	(11.27)
									120	(11.76)
									125	(12.25)
									130	(12.74)
									135	(13.23)
									140	(13.72)
									145	(14.21)
									150	(14.7)
									155	(15.19)
									160	(15.68)
									165	(16.17)
									170	(16.66)
									175	(17.15)
									180	(17.64)
									183	(17.93)
									186	(18.23)
									189	(18.52)
									192	(18.82)
									195	(19.11)
									198	(19.4)
									201	(19.7)
									203	(19.89)

* For USC units : $W = 51.5 * A * P1 * Kd * Kb * Kc * KN * KSh$

API STD 520 Air Capacity Capacity for air (Kg/h at 20°C with 10% overpressure) : $W = A * C * Kd * Kb * Kc * P1 * \sqrt{\frac{M}{TZ}}$

set pressure Kg/cm ² (Mpag)	ORIFICE LETTER AND									
	D	E	F	G	H	J	K	L	M	
	70.97	126.45	198.71	326.45	506.45	834.19	1187.74	1846.45	2325.16	
1 (0.1)	105	187	294	483	749	1,233	1,756	2,729	3,437	
2 (0.2)	159	283	445	731	1,135	1,869	2,661	4,136	5,209	
3 (0.3)	213	380	597	980	1,520	2,504	3,566	5,543	6,981	
4 (0.4)	267	476	748	1,229	1,906	3,140	4,471	6,950	8,752	
5 (0.5)	321	572	899	1,478	2,292	3,776	5,376	8,357	10,524	
6 (0.6)	375	669	1,051	1,726	2,678	4,411	6,281	9,764	12,296	
7 (0.7)	429	765	1,202	1,975	3,064	5,047	7,186	11,171	14,068	
8 (0.8)	483	861	1,354	2,224	3,450	5,683	8,091	12,578	15,839	
9 (0.9)	538	958	1,505	2,473	3,836	6,318	8,996	13,985	17,611	
10 (1)	592	1,054	1,656	2,721	4,222	6,954	9,901	15,392	19,383	
11 (1.1)	646	1,150	1,808	2,970	4,608	7,590	10,806	16,799	21,155	
12 (1.2)	700	1,247	1,959	3,219	4,994	8,225	11,711	18,206	22,926	
13 (1.3)	754	1,343	2,111	3,468	5,380	8,861	12,616	19,613	24,698	
14 (1.4)	808	1,440	2,262	3,716	5,766	9,497	13,521	21,020	26,470	
15 (1.5)	862	1,536	2,414	3,965	6,151	10,132	14,426	22,427	28,242	
16 (1.6)	916	1,632	2,565	4,214	6,537	10,768	15,332	23,834	30,014	
17 (1.7)	970	1,729	2,716	4,463	6,923	11,404	16,237	25,241	31,785	
18 (1.8)	1,024	1,825	2,868	4,711	7,309	12,039	17,142	26,648	33,557	
19 (1.9)	1,078	1,921	3,019	4,960	7,695	12,675	18,047	28,055	35,329	
20 (2)	1,132	2,018	3,171	5,209	8,081	13,310	18,952	29,462	37,101	
21 (2.1)	1,186	2,114	3,322	5,458	8,467	13,946	19,857	30,869	38,872	
22 (2.2)	1,241	2,210	3,473	5,706	8,853	14,582	20,762	32,276	40,644	
23 (2.3)	1,295	2,307	3,625	5,955	9,239	15,217	21,667	33,683	42,416	
24 (2.4)	1,349	2,403	3,776	6,204	9,625	15,853	22,572	35,090	44,188	
25 (2.5)	1,403	2,499	3,928	6,453	10,011	16,489	23,477	36,497	45,959	
26 (2.6)	1,457	2,596	4,079	6,701	10,396	17,124	24,382	37,904	47,731	
27 (2.7)	1,511	2,692	4,231	6,950	10,782	17,760	25,287	39,311	49,503	
28 (2.8)	1,565	2,788	4,382	7,199	11,168	18,396	26,192	40,718	51,275	
29 (2.9)	1,619	2,885	4,533	7,448	11,554	19,031	27,097	42,125	53,046	
30 (3)	1,673	2,981	4,685	7,696	11,940	19,667	28,002	43,532	54,818	
40 (4)	2,214	3,945	6,199	10,184	15,799	26,023	37,053	57,602	72,536	
50 (5)	2,755	4,908	7,713	12,671	19,658	32,380	46,103	71,672	90,253	
60 (6)	3,296	5,872	9,227	15,159	23,517	38,736	55,154	85,742	107,971	
70 (7)	3,836	6,835	10,741	17,647	27,377	45,093	64,204	99,812	125,689	
80 (8)	4,377	7,799	12,256	20,134	31,236	51,449	73,255	113,881		
90 (9)	4,918	8,762	13,770	22,622	35,095	57,806	82,305	127,951		
100 (10)	5,459	9,726	15,284	25,109	38,954	64,162	91,356	142,021		
110 (11)	6,000	10,690	16,798	27,597	42,813	70,519	100,407			
120 (12)	6,540	11,653	18,312	30,084	46,672	76,875	109,457			
130 (13)	7,081	12,617	19,826	32,572	50,531	83,232	118,508			
140 (14)	7,622	13,580	21,341	35,059	54,391	89,588	127,558			
150 (15)	8,163	14,544	22,855	37,547	58,250	95,945	136,609			
160 (16)	8,703	15,507	24,369	40,034	62,109	102,301				
170 (17)	9,244	16,471	25,883	42,522	65,968	108,658				
180 (18)	9,785	17,434	27,397	45,009	69,827	115,014				
190 (19)	10,326	18,398	28,911	47,497	73,686					
200 (20)	10,867	19,361	30,426	49,985						
210 (21)	11,407	20,325	31,940	52,472						
220 (22)	11,948	21,289	33,454	54,960						
230 (23)	12,489	22,252	34,968	57,447						
240 (24)	13,030	23,216	36,482	59,935						
250 (25)	13,571	24,179	37,996	62,422						
260 (26)	14,111	25,143	39,511	64,910						
270 (27)	14,652	26,106	41,025							
280 (28)	15,193	27,070	42,539							
290 (29)	15,734	28,033	44,053							
300 (30)	16,274	28,997	45,567							
310 (31)	16,815	29,960	47,081							
320 (32)	17,356	30,924	48,595							
330 (33)	17,897	31,888	50,110							
340 (34)	18,438	32,851	51,624							
350 (35)	18,978	33,815	53,138							
360 (36)	19,519	34,778								
370 (37)	20,060	35,742								
380 (38)	20,601	36,705								
390 (39)	21,142	37,669								
400 (40)	21,682	38,632								
410 (41)	22,223	39,596								
420 (42)	22,764	40,559								

Capacity Table



Metric units

EFFECTIVE AREA (mm ²)									set pressure	
N	P	Q	R	T	V	W	Y		Kg/cm ²	(Mpag)
2798.06	4115.48	7132.89	10334.17	16787.71	25449.63	35966.38	49082.48		1	(0.1)
4,136	6,084	10,544	15,276	24,816	37,620	53,166	72,555		2	(0.2)
6,268	9,220	15,979	23,151	37,608	57,013	80,573	109,955		3	(0.3)
8,400	12,356	21,414	31,025	50,400	76,405	107,979	147,356		4	(0.4)
10,532	15,492	26,850	38,900	63,192	95,798	135,385	184,757		5	(0.5)
12,665	18,628	32,285	46,775	75,985	115,190	162,791	222,157		6	(0.6)
14,797	21,763	37,720	54,649	88,777	134,583	190,197	259,558		7	(0.7)
16,929	24,899	43,155	62,524	101,569	153,975	217,604	296,959		8	(0.8)
19,061	28,035	48,591	70,398	114,361	173,368	245,010	334,359		9	(0.9)
21,193	31,171	54,026	78,273	127,153	192,760	272,416	371,760		10	(1)
23,325	34,307	59,461	86,148	139,945	212,153	299,822	409,161		11	(1.1)
25,457	37,443	64,896	94,022	152,738	231,545	327,229	446,561		12	(1.2)
27,589	40,579	70,332	101,897	165,530	250,938	354,635	483,962		13	(1.3)
29,721	43,715	75,767	109,771	178,322	270,330	382,041	521,363		14	(1.4)
31,854	46,851	81,202	117,646	191,114	289,723	409,447	558,763		15	(1.5)
33,986	49,987	86,637	125,521	203,906	309,115	436,854	596,164		16	(1.6)
36,118	53,123	92,072	133,395	216,698	328,508	464,260	633,564		17	(1.7)
38,250	56,259	97,508	141,270	229,491	347,900	491,666	670,965		18	(1.8)
40,382	59,395	102,943	149,144	242,283	367,293	519,072	708,366		19	(1.9)
42,514	62,531	108,378	157,019	255,075	386,685	546,478	745,766		20	(2)
44,646	65,667	113,813	164,893	267,867	406,078	573,885	783,167		21	(2.1)
46,778	68,803	119,249	172,768	280,659	425,470	601,291	820,568		22	(2.2)
48,910	71,939	124,684							23	(2.3)
51,043	75,075	130,119							24	(2.4)
53,175	78,211	135,554							25	(2.5)
55,307	81,347	140,990							26	(2.6)
57,439	84,483	146,425							27	(2.7)
59,571	87,619	151,860							28	(2.8)
61,703	90,755	157,295							29	(2.9)
63,835	93,891	162,730							30	(3)
65,967	97,027	168,166							40	(4)
87,288	128,387	222,518							50	(5)
108,610	159,747								60	(6)
129,931	191,106								70	(7)
151,252	222,466								80	(8)
									90	(9)
									100	(10)
									110	(11)
									120	(12)
									130	(13)
									140	(14)
									150	(15)
									160	(16)
									170	(17)
									180	(18)
									190	(19)
									200	(20)
									210	(21)
									220	(22)
									230	(23)
									240	(24)
									250	(25)
									260	(26)
									270	(27)
									280	(28)
									290	(29)
									300	(30)
									310	(31)
									320	(32)
									330	(33)
									340	(34)
									350	(35)
									360	(36)
									370	(37)
									380	(38)
									390	(39)
									400	(40)
									410	(41)
									420	(42)

* For USC units : $W = A * C * Kd * Kb * Kc * P_1 * \sqrt{\frac{M}{TZ}}$

API STD 520 Water Capacity

Capacity for water (m3/h with 10% overpressure) : $W = \frac{A * Kd * Kc * Kv * Kw * Kp}{11.78 * \sqrt{\frac{G}{P1 - P2}}}$

set pressure Kg/cm ² (Mpag)	ORIFICE LETTER AND									
	D 70.97	E 126.45	F 198.71	G 326.45	H 506.45	J 834.19	K 1187.74	L 1846.45	M 2325.16	
1 (0.1)	1.5	2.6	4.1	6.8	10.5	17.4	24.7	38.4	48.4	
2 (0.2)	2.1	3.7	5.8	9.6	14.9	24.5	34.9	54.3	68.4	
3 (0.3)	2.6	4.6	7.2	11.8	18.2	30.1	42.8	66.5	83.8	
4 (0.4)	3	5.3	8.3	13.6	21.1	34.7	49.4	76.8	96.7	
5 (0.5)	3.3	5.9	9.2	15.2	23.6	38.8	55.2	85.9	108.2	
6 (0.6)	3.6	6.4	10.1	16.6	25.8	42.5	60.5	94.1	118.5	
7 (0.7)	3.9	7	10.9	18	27.9	45.9	65.4	101.6	128	
8 (0.8)	4.2	7.4	11.7	19.2	29.8	49.1	69.9	108.6	136.8	
9 (0.9)	4.4	7.9	12.4	20.4	31.6	52.1	74.1	115.2	145.1	
10 (1)	4.7	8.3	13.1	21.5	33.3	54.9	78.1	121.5	153	
11 (1.1)	4.9	8.7	13.7	22.5	34.9	57.6	81.9	127.4	160.4	
12 (1.2)	5.1	9.1	14.3	23.5	36.5	60.1	85.6	133.1	167.5	
13 (1.3)	5.3	9.5	14.9	24.5	38	62.6	89.1	138.5	174.4	
14 (1.4)	5.5	9.8	15.5	25.4	39.4	64.9	92.4	143.7	181	
15 (1.5)	5.7	10.2	16	26.3	40.8	67.2	95.7	148.8	187.3	
16 (1.6)	5.9	10.5	16.5	27.2	42.1	69.4	98.8	153.6	193.5	
17 (1.7)	6.1	10.8	17	28	43.4	71.5	101.9	158.4	199.4	
18 (1.8)	6.3	11.2	17.5	28.8	44.7	73.6	104.8	163	205.2	
19 (1.9)	6.4	11.5	18	29.6	45.9	75.6	107.7	167.4	210.8	
20 (2)	6.6	11.8	18.5	30.4	47.1	77.6	110.5	171.8	216.3	
21 (2.1)	6.8	12.1	18.9	31.1	48.3	79.5	113.2	176	221.6	
22 (2.2)	6.9	12.3	19.4	31.9	49.4	81.4	115.9	180.2	226.9	
23 (2.3)	7.1	12.6	19.8	32.6	50.5	83.2	118.5	184.2	232	
24 (2.4)	7.2	12.9	20.3	33.3	51.6	85	121	188.2	237	
25 (2.5)	7.4	13.2	20.7	34	52.7	86.8	123.5	192	241.8	
26 (2.6)	7.5	13.4	21.1	34.6	53.7	88.5	126	195.9	246.6	
27 (2.7)	7.7	13.7	21.5	35.3	54.7	90.2	128.4	199.6	251.3	
28 (2.8)	7.8	13.9	21.9	35.9	55.7	91.8	130.7	203.2	255.9	
29 (2.9)	8	14.2	22.3	36.6	56.7	93.4	133.1	206.8	260.5	
30 (3)	8.1	14.4	22.6	37.2	57.7	95	135.3	210.4	264.9	
40 (4)	9.3	16.6	26.1	42.9	66.6	109.7	156.3	242.9	305.9	
50 (5)	10.4	18.6	29.2	48	74.5	122.7	174.7	271.6	342	
60 (6)	11.4	20.4	32	52.6	81.6	134.4	191.4	297.5	374.7	
70 (7)	12.4	22	34.6	56.8	88.1	145.2	206.7	321.4	404.7	
80 (8)	13.2	23.5	37	60.7	94.2	155.2	221	343.5		
90 (9)	14	25	39.2	64.4	99.9	164.6	234.4	364.4		
100 (10)	14.8	26.3	41.3	67.9	105.4	173.5	247.1	384.1		
110 (11)	15.5	27.6	43.4	71.2	110.5	182	259.1			
120 (12)	16.2	28.8	45.3	74.4	115.4	190.1	270.7			
130 (13)	16.8	30	47.1	77.4	120.1	197.9	281.7			
140 (14)	17.5	31.1	48.9	80.3	124.7	205.3	292.3			
150 (15)	18.1	32.2	50.6	83.2	129	212.5	302.6			
160 (16)	18.7	33.3	52.3	85.9	133.3	219.5				
170 (17)	19.2	34.3	53.9	88.5	137.4	226.3				
180 (18)	19.8	35.3	55.5	91.1	141.3	232.8				
190 (19)	20.3	36.3	57	93.6	145.2					
200 (20)	20.9	37.2	58.5	96						
210 (21)	21.4	38.1	59.9	98.4						
220 (22)	21.9	39	61.3	100.7						
230 (23)	22.4	39.9	62.7	103						
240 (24)	22.9	40.7	64	105.2						
250 (25)	23.3	41.6	65.4	107.4						
260 (26)	23.8	42.4	66.7	109.5						
270 (27)	24.3	43.2	67.9							
280 (28)	24.7	44	69.2							
290 (29)	25.1	44.8	70.4							
300 (30)	25.6	45.6	71.6							
310 (31)	26	46.3	72.8							
320 (32)	26.4	47.1	73.9							
330 (33)	26.8	47.8	75.1							
340 (34)	27.2	48.5	76.2							
350 (35)	27.6	49.2	77.3							
360 (36)	28	49.9								
370 (37)	28.4	50.6								
380 (38)	28.8	51.3								
390 (39)	29.2	51.9								
400 (40)	29.5	52.6								
410 (41)	29.9	53.3								
420 (42)	30.3	53.9								

Capacity Table



Metric units

EFFECTIVE AREA (mm ²)									set pressure	
N	P	Q	R	T	V	W	Y		Kg/cm ²	(Mpag)
2798.06	4115.48	7132.89	10334.17	16787.71	25449.63	35966.38	49082.48		1	(0.1)
58.2	85.6	148.4	215	349.2	529.4	748.2	1021		2	(0.2)
82.3	121.1	209.8	304	493.9	748.7	1058.1	1443.9		3	(0.3)
100.8	148.3	257	372.3	604.9	916.9	1295.9	1768.4		4	(0.4)
116.4	171.2	296.8	429.9	698.4	1058.8	1496.3	2042		5	(0.5)
130.1	191.4	331.8	480.7	780.9	1183.8	1672.9	2283		6	(0.6)
142.6	209.7	363.4	526.6	855.4	1296.8	1832.6	2500.9		7	(0.7)
154	226.5	392.6	568.8	923.9	1400.7	1979.5	2701.3		8	(0.8)
164.6	242.1	419.7	608	987.7	1497.4	2116.1	2887.8		9	(0.9)
174.6	256.8	445.1	644.9	1047.6	1588.2	2244.5	3063		10	(1)
184.1	270.7	469.2	679.8	1104.3	1674.1	2365.9	3228.7		11	(1.1)
193	283.9	492.1	713	1158.2	1755.8	2481.4	3386.3		12	(1.2)
201.6	296.6	514	744.7	1209.7	1833.9	2591.7	3536.9		13	(1.3)
209.9	308.7	535	775.1	1259.1	1908.8	2697.5	3681.3		14	(1.4)
217.8	320.3	555.2	804.3	1306.6	1980.8	2799.4	3820.2		15	(1.5)
225.4	331.6	574.7	832.6	1352.5	2050.3	2897.6	3954.3		16	(1.6)
232.8	342.4	593.5	859.9	1396.9	2117.6	2992.7	4084		17	(1.7)
240	353	611.8	886.3	1439.8	2182.8	3084.8	4209.7		18	(1.8)
246.9	363.2	629.5	912	1481.6	2246	3174.2	4331.7		19	(1.9)
253.7	373.2	646.8	937	1522.2	2307.6	3261.2	4450.4		20	(2)
260.3	382.9	663.6	961.4	1561.7	2367.5	3345.9	4566.1		21	(2.1)
266.7	392.3	679.9	985.1	1600.3	2426	3428.5	4678.8		22	(2.2)
273	401.5	695.9							23	(2.3)
279.1	410.6	711.6							24	(2.4)
285.1	419.4	726.9							25	(2.5)
291	428	741.9							26	(2.6)
296.8	436.5	756.6							27	(2.7)
302.4	444.8	771							28	(2.8)
308	453	785.1							29	(2.9)
313.4	461	799							30	(3)
318.8	468.9	812.7							40	(4)
368.1	541.4	938.4							50	(5)
411.6	605.3								60	(6)
450.9	663.1								70	(7)
487	716.3								80	(8)
									90	(9)
									100	(10)
									110	(11)
									120	(12)
									130	(13)
									140	(14)
									150	(15)
									160	(16)
									170	(17)
									180	(18)
									190	(19)
									200	(20)
									210	(21)
									220	(22)
									230	(23)
									240	(24)
									250	(25)
									260	(26)
									270	(27)
									280	(28)
									290	(29)
									300	(30)
									310	(31)
									320	(32)
									330	(33)
									340	(34)
									350	(35)
									360	(36)
									370	(37)
									380	(38)
									390	(39)
									400	(40)
									410	(41)
									420	(42)

* For USC units : $W = \frac{38 * A * K_d * K_c * K_v * K_w * K_p}{\sqrt{\frac{G}{P_1 - P_2}}}$



Reference

01 Figures	61
02 Definition for SRV (Safety Relief Valve)	66
03 API STD 527	67



01 Figures



A Correction factor for Napier equation, K_n

Correction factor for Napier equation is used when the steam pressure P_1 is greater than 1500 psia and up to 3200 psia.

This factor has been adopted by ASME to account for the deviation between steam flow as determined by Napier's equation and actual saturated steam flow at high pressures. K_n can also be calculated by the following equation or may be taken from Figure A.1.

Metric units:
$$K_n = \frac{0.02763 P_1 - 1000}{0.03324 P_1 - 1061}$$

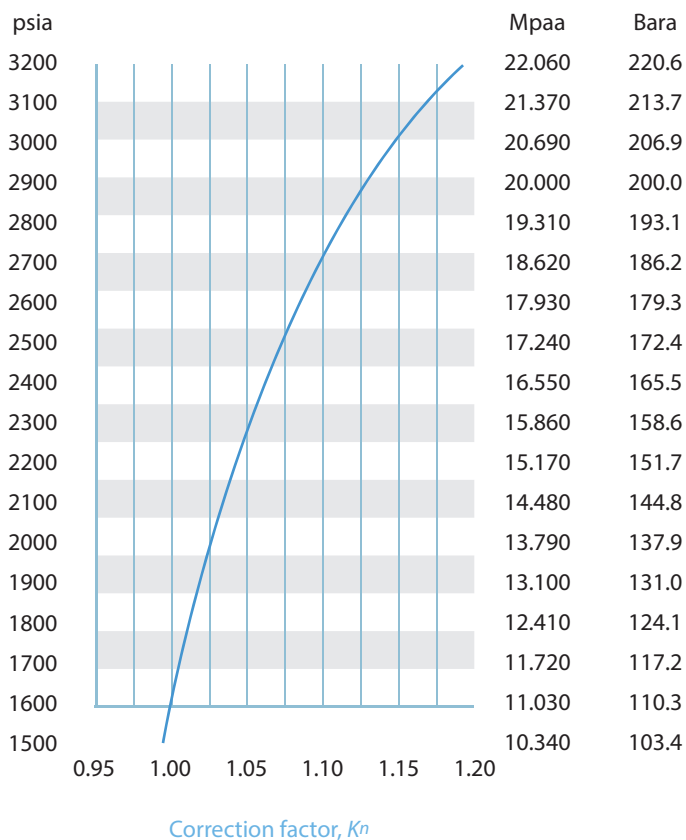

FIGURE A.1

B Superheat Correction Factor, Ksh

The steam sizing formulas are based on the flow of dry saturated steam. To size for superheated steam, the superheat correction factor is used to correct the calculated saturated steam flow to superheated steam flow. For saturated steam, $K_{sh} = 1$. When the steam is superheated, use Figure B.1 and read the superheat correction factor under the total steam temperature column.

Set Pressure (psig)	Temperature (degrees Fahrenheit)									
	300	400	500	600	700	800	900	1000	1100	1200
15	1.00	0.98	0.93	0.88	0.84	0.80	0.77	0.74	0.72	0.70
20	1.00	0.98	0.93	0.88	0.84	0.80	0.77	0.74	0.72	0.70
40	1.00	0.99	0.93	0.88	0.84	0.81	0.77	0.74	0.72	0.70
60	1.00	0.99	0.93	0.88	0.84	0.81	0.77	0.75	0.72	0.70
80	1.00	0.99	0.93	0.88	0.84	0.81	0.77	0.75	0.72	0.70
100	1.00	0.99	0.94	0.89	0.84	0.81	0.77	0.75	0.72	0.70
120	1.00	0.99	0.94	0.89	0.84	0.81	0.78	0.75	0.72	0.70
140	1.00	0.99	0.94	0.89	0.85	0.81	0.78	0.75	0.72	0.70
160	1.00	0.99	0.94	0.89	0.85	0.81	0.78	0.75	0.72	0.70
180	1.00	0.99	0.94	0.89	0.85	0.81	0.78	0.75	0.72	0.70
200	1.00	0.99	0.95	0.89	0.85	0.81	0.78	0.75	0.72	0.70
220	1.00	0.99	0.95	0.89	0.85	0.81	0.78	0.75	0.72	0.70
240	-	1.00	0.95	0.90	0.85	0.81	0.78	0.75	0.72	0.70
260	-	1.00	0.95	0.90	0.85	0.81	0.78	0.75	0.72	0.70
280	-	1.00	0.96	0.90	0.85	0.81	0.78	0.75	0.72	0.70
300	-	1.00	0.96	0.90	0.85	0.81	0.78	0.75	0.72	0.70
350	-	1.00	0.96	0.90	0.86	0.82	0.78	0.75	0.72	0.70
400	-	1.00	0.96	0.91	0.86	0.82	0.78	0.75	0.72	0.70
500	-	1.00	0.96	0.92	0.86	0.82	0.78	0.75	0.73	0.70
600	-	1.00	0.97	0.92	0.87	0.82	0.79	0.75	0.73	0.70
800	-	-	1.00	0.95	0.88	0.83	0.79	0.76	0.73	0.70
1000	-	-	1.00	0.96	0.89	0.84	0.78	0.76	0.73	0.71
1250	-	-	1.00	0.97	0.91	0.85	0.80	0.77	0.74	0.71
1500	-	-	-	1.00	0.93	0.86	0.81	0.77	0.74	0.71
1750	-	-	-	1.00	0.94	0.86	0.81	0.77	0.73	0.70
2000	-	-	-	1.00	0.95	0.86	0.80	0.76	0.72	0.69
2500	-	-	-	1.00	0.95	0.85	0.78	0.73	0.69	0.66
3000	-	-	-	-	1.00	0.82	0.74	0.69	0.65	0.62

FIGURE B.1



C Properties of Gases

Gas	Molecular Weight	Specific Heat Ratio (k = Cp/Cv) at 60°F and One Atmosphere	Critical Flow Pressure Ratio at 60°F and One Atmosphere	Specific Gravity at 60°F and One Atmosphere	Critical Constants		Condensation Temperature One Atmosphere (°F)	Flammability Limits (volume percent in air mixture)	References
					Pressure (psia)	Temperature (°F)			
Methane	16.04	1.31	0.54	0.554	673	-116	-259	5.0-15.0	1
Ethane	30.07	1.19	0.57	1.058	718	90	-128	2.9-13.8	1
Ethylene	28.03	1.24	0.57	0.969	742	50	-155	2.7-34.8	1
Propane	44.09	1.13	0.58	1.522	617	206	-44	2.1-9.5	1
Propylene	47.08	1.15	0.58	1.453	667	197	-54	2.8-10.8	2, 3
Isobutane	58.12	1.18	0.59	2.007	529	273	11	1.8-8.4	1
n-Butane	58.12	1.19	0.59	2.007	551	304	31	1.9-8.4	1
I-Butane	56.10	1.11	0.59	1.937	543	276	21	1.4-9.3	2, 3
Isopentane	72.15	1.08	0.59	2.491	483	369	82	1.4-8.3	1
n-Pentane	72.15	1.08	0.59	2.491	490	386	97	1.4-7.8	1
I-Pentene	70.13	1.08	0.59	2.421	586	377	86	1.4-8.7	1
n-Hexane	86.18	1.06	0.59	2.973	437	454	156	1.2-7.7	1
Benzene	78.11	1.12	0.58	2.697	714	552	176	1.3-7.9	2, 3
n-Heptane	100.20	1.05	0.60	3.459	397	513	209	1.0-7.0	1
Toluene	92.13	1.09	0.59	3.181	590	604	231	1.2-7.1	2, 3
n-Octane	114.22	1.05	0.60	3.944	362	564	258	0.96-	1
n-Nonane	128.23	1.04	0.60	4.428	552	610	303	0.87-2.9	1
n-Decane	142.28	1.03	0.60	4.912	304	632	345	0.78-2.6	1
Air	29.96	1.40	0.53	1.000	547	-221	-313	-	2, 3
Ammonia	17.03	1.30	0.53	0.588	1636	270	-28	15.5-27.0	2, 3
Carbon Dioxide	44.01	1.29	0.55	1.519	1071	88	-109	-	2, 3
Hydrogen	2.02	1.41	0.52	0.0696	188	-400	-423	4.0-74.2	2, 3
Hydrogen sulfide	34.08	1.32	0.53	1.176	1306	213	-77	4.3-45.5	2, 3
Sulfur dioxide	64.04	1.27	0.55	2.212	1143	316	14	-	2, 3
Steam	18.01	1.33	0.54	0.622	3206	706	212	-	2, 3

D Curve for Evaluating Coefficient C in the Flow Equation form the Specific Heat Ratio, Assuming Ideal Gas Behavior

The following formula equates the ratio of specific heats to the coefficient C used in sizing methods for gases and vapors. Figure D.2 provides the calculated solution to this formula, where k is the ratio of specific heats.

1. The equation for this curve is

$$C = 520 \sqrt{k \left(\frac{2}{k+1} \right)^{(k+1)/(k-1)}}$$

2. The units for the coefficient C are $\sqrt{\text{lb}_m \text{lb}_{mole} \text{ } ^\circ\text{R} / \text{lb}_f \text{hr}}$.

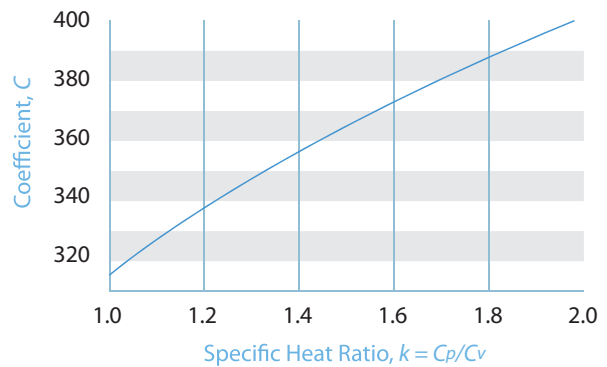

FIGURE D.1

k	C	k	C	k	C	k	C
1.00	315 ^a	1.30	347	1.60	372	1.90	394
1.01	317	1.31	348	1.61	373	1.91	395
1.02	318	1.32	349	1.62	374	1.92	395
1.03	319	1.33	350	1.63	375	1.93	396
1.04	320	1.34	351	1.64	376	1.94	397
1.05	321	1.35	352	1.65	376	1.95	397
1.06	322	1.36	353	1.66	377	1.96	398
1.07	323	1.37	353	1.67	378	1.97	398
1.08	325	1.38	354	1.68	379	1.98	399
1.09	326	1.39	355	1.69	379	1.99	400
1.10	327	1.40	356	1.70	380	2.00	400
1.11	328	1.41	357	1.71	381	-	-
1.12	329	1.42	358	1.72	382	-	-
1.13	330	1.43	359	1.73	382	-	-
1.14	331	1.44	360	1.74	383	-	-
1.15	332	1.45	360	1.75	384	-	-
1.16	333	1.46	361	1.76	384	-	-
1.17	334	1.47	362	1.77	385	-	-
1.18	335	1.48	363	1.78	386	-	-
1.19	336	1.49	364	1.79	386	-	-
1.20	337	1.50	365	1.80	387	-	-
1.21	338	1.51	365	1.81	388	-	-
1.22	339	1.52	366	1.82	389	-	-
1.23	340	1.53	367	1.83	389	-	-
1.24	341	1.54	368	1.84	390	-	-
1.25	342	1.55	369	1.85	391	-	-
1.26	343	1.56	369	1.86	391	-	-
1.27	344	1.57	370	1.87	392	-	-
1.28	345	1.58	371	1.88	393	-	-
1.29	346	1.59	372	1.89	393	-	-
1.30	347	1.60	373	1.90	394	-	-

The limit of C, as k approaches 1.00, is 315.

FIGURE D.2



E Capacity Correction Factor, Kv, Due to Viscosity

When valve is sized for viscous liquid service, it is suggested that it would be sized first as for a non-viscous type application in order to obtain a preliminary required effective discharge area A. From the manufacturer’s standard effective orifice sizes, select the next larger orifice size and calculate the Reynold’s number, R, per the following formula.

$$\text{Metric units: } R = \frac{Q (18,800 \text{ G})}{U \sqrt{A}}$$

Q = Flow rate at the flowing temperature(ℓ/min)

G = Specific gravity of the liquid

U = Absolute viscosity(CP)

A = Effective discharge area (mm²)

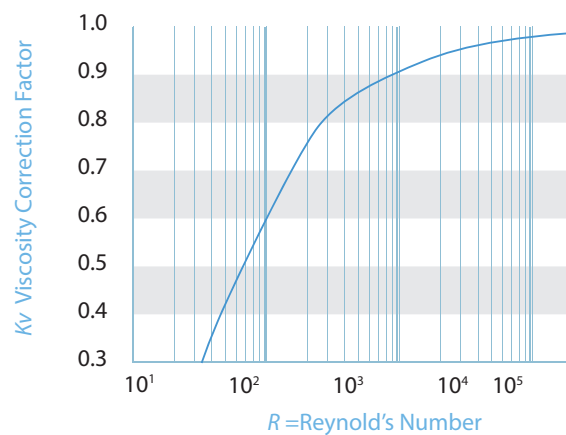

FIGURE E.1

F Capacity Correction Factors, Kp, Due to Overpressure for Pressure Relief Valves in Liquid Service

The curve above shows that up to and including 25% overpressure, capacity is affected by the change in lift, the change in the orifice discharge coefficient, and the change in overpressure. Above 25%, capacity is affected only by the change in overpressure. Valves operating at low overpressure tend to chatter. Therefore, overpressure of less than 10% should be avoided.

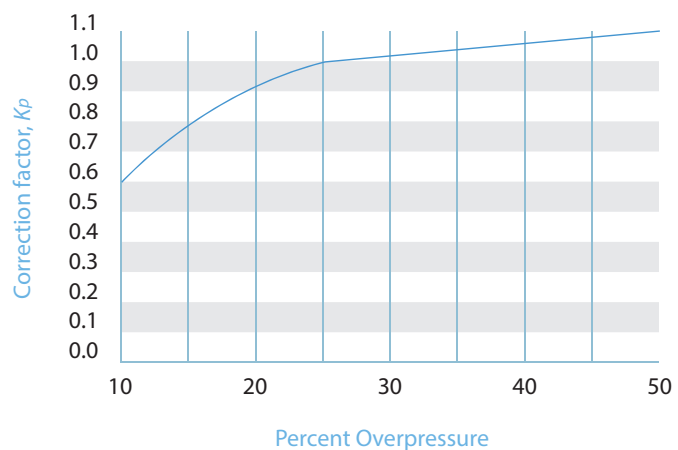

FIGURE F.1

02

Definition for SRV(Safety Relief Valve)

Accumulation The pressure increase over the maximum allowable working pressure of the vessel allowed during discharge through the pressure relief device, expressed in pressure units or as a percentage of MAWP or design pressure. Maximum allowable accumulations are established by applicable codes for emergency operating and fire contingencies.

Back Pressure Back Pressure is static pressure existing at the outlet of a pressure relief device due to pressure in the discharge system.

Blowdown The different between set pressure and reseating pressure of a pressure relief valve, expressed as a percentage of the set pressure, or actual pressure units.

Built-up Back Pressure Pressure existing at the outlet of a pressure relief device caused by the flow through that particular device into a discharge system.

Constant Back Pressure A superimposed back pressure which is constant with time.

Chatter The abnormal, rapid reciprocating motion of the movable parts of a valve in which the disc contacts the seat.

Closing Pressure Closing Pressure is the valve of decreasing inlet static pressure at which the valve disk reestablishes contact with the seat or at which lift becomes zero.

Flutter The abnormal, rapid reciprocating motion of the movable parts of a valve in which the disc does not contact the seat.

Maximum Allowable Working Pressure The sum of the maximum allowable working pressure and the maximum allowable accumulation.

Operating Pressure Operating pressure is the pressure to which the vessel is usually subjected in service. A pressure vessel is normally designed for a maximum allowable working pressure that will provide a suitable margin above the operating pressure in order to prevent any undesirable operation of the relieving device.

Overpressure The pressure increase over the set pressure of the relieving device allowed to achieve

rated flow. Overpressure is expressed in pressure units or as a percentage of set pressure. It is the same as accumulation only when the relieving device is set to open at the maximum allowable working pressure of the vessel.

Rated Relieving Capacity Rated relieving capacity is the relieving capacity used as the basis for the application of a pressure relief device, code or regulation and is provided by the manufacturer. Note: The capacity marked on the device is the rated capacity on steam, air, gas or water as required by the applicable code.

Relief Valve A relief valve is a spring loaded pressure relief valve actuated by the static pressure upstream of the valve. The valve opens normally in proportion to the pressure increase over the opening pressure. A relief valve is used primarily with incompressible fluids.

Safety Relief Valve A spring loaded pressure relief valve that may be used as either a safety or relief valve depending on the application.

Safety Valve A spring loaded pressure relief valve actuated by the static pressure upstream of the valve and characterized by rapid opening or pop action. A safety valve is normally used with compressible fluids.

Set Pressure The inlet gauge pressure at which the pressure relief device is set to open under service conditions.

Simmer The audible or visible escape of fluid between the seat and disk at an inlet static pressure below the popping pressure and at no measurable capacity. It applies to safety or safety relief valves on designed to function.

Superimposed back pressure The static pressure that exists at the outlet of a pressure relief device at the time the device is required to operate. It is the result of pressure in the discharge system coming from other sources and may be constant or variable.

Variable Back Pressure A superimposed back pressure that will vary with time.

* Ref.: ASME PTC 25- 2008, API STD 520 Part I

03 API STD 527



Seat Tightness of Pressure Relief Valves

(Reprint of API STD 527)

SECTION 1.

SCOPE

This standard describes methods of determining the seat tightness of metal and soft-seated pressure relief valves, including those of conventional, bellows, and pilot-operated designs. The maximum acceptable leakage rates are defined for pressure relief valves with set pressures from 15 pounds per square inch gauge (103 kilopascals gauge) to 6,000 pounds per square inch gauge (41,379 kilopascals gauge). If greater seat tightness is required, the purchaser shall specify it in the purchase order. The test medium for determining the seat tightness – air, steam, or water – shall be the same as that used for determining the set pressure of the valve.

For dual-service valves, the test medium – air, steam, or water – shall be the same as the primary relieving medium. To ensure safety, the procedures outlined in this standard shall be performed by persons experienced in the use and functions of pressure relief valves.

SECTION 2.

TESTING WITH AIR

2.1 Test Apparatus

A test arrangement for determining seat tightness with air is shown in Figure 1. Leakage shall be measured using a tube with an outside diameter of $\frac{5}{16}$ inch (7.9 millimeters) and a wall thickness of 0.035 inch (0.89 millimeter). The tube end shall be cut square and smooth. The tube opening shall be $\frac{1}{2}$

inch (12.7 millimeters) below the surface of the water. The tube shall be perpendicular to the surface of the water.

Arrangement shall be made to safely relieve or contain body pressure in case the valve accidentally pops (see Figure 2).

2.2 Procedure

2.2.1 TEST MEDIUM

The test medium shall be air (or nitrogen) near ambient temperature.

2.2.2 TEST CONFIGURATION

The valve shall be vertically mounted on the test stand, and the test apparatus shall be attached to the valve outlet, as shown in Figure 1. All openings—including but not limited to caps, drain holes, vents, and outlets—shall be closed.

2.2.3 TEST PRESSURE

For a valve whose set pressure is greater than 50

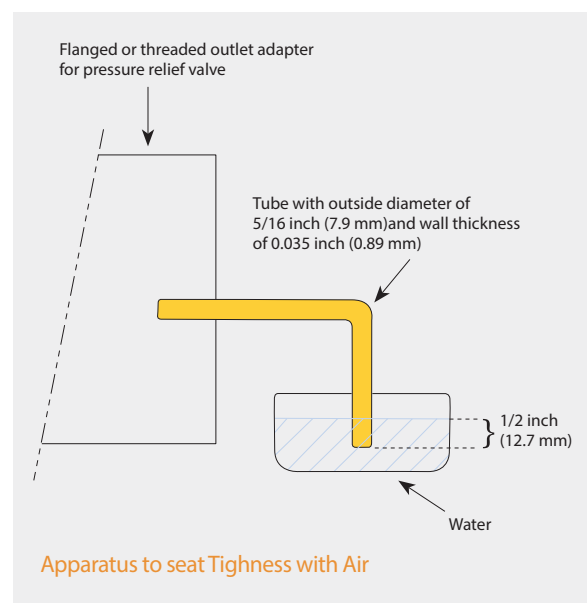

pounds per square inch gauge (345 kilopascals gauge), the leakage rate in bubbles per minute shall be determined with the test pressure at the valve inlet held at 90 percent of the set pressure. For a valve set at 50 pounds per square inch gauge (345 kilopascals gauge) or less, the test pressure shall be held at 5 pounds per square inch (34.5 kilopascals) less than the set pressure.

2.2.4 LEAKAGE TEST

Before the leakage test, the set pressure shall be demonstrated, and all valve body joints and fittings should be checked with a suitable solution to ensure that all joints are tight.

Before the bubble count, the test pressure shall be applied for at least 1 minute for a valve whose nominal pipe size is 2 inches (50 millimeters) or smaller; 2 minutes for a valve whose nominal pipe size is 2½, 3, or 4 inches (65, 80, or 100 millimeters); and 5 minutes for a valve whose nominal pipe size is 6 inches (150 millimeters) or larger.

The valve shall then be observed for leakage for at least 1 minute.

2.3 Acceptance Criteria

For a valve with a metal seat, the leakage rate in bubbles per minute shall not exceed the appropriate value in Table 1.

For a soft-seated valve, there shall be no leakage for 1 minute (0 bubbles per minute).

SECTION 3.

TESTING WITH STEAM

3.1 Procedure

3.1.1 TEST MEDIUM

The test medium shall be saturated steam.

3.1.2 TEST CONFIGURATION

The valve shall be vertically mounted on the steam test stand.

3.1.3 TEST PRESSURE

For a valve whose set pressure is greater than 50 pounds per square inch gauge (345 kilopascals gauge), the seat tightness shall be determined with the test pressure at the valve inlet held at 90 percent of the set pressure. For a valve set at 50 pounds per square inch gauge (345 kilopascals gauge) or less, the test pressure shall be held at 5 pounds per square inch (34.5 kilopascals) less than the set pressure.

3.1.4 LEAKAGE TEST

Before starting the seat tightness test, the set pressure shall be demonstrated, and the test pressure shall be held for at least 3 minutes. Any condensate in the body bowl shall be removed before the seat tightness test. Air (or nitrogen) may be used to dry condensate.

After any condensate has been removed, the inlet pressure shall be increased to the test pressure. Tightness shall then be checked visually using a black background.

The valve shall then be observed for leakage for at least 1 minute.

3.2 Acceptance Criteria

For both metal- and soft-seated valves, there shall be no audible or visible leakage for 1 minute.



SECTION 4.

TESTING WITH WATER

4.1 Procedure

4.1.1 TEST MEDIUM

The test medium shall be water near ambient temperature.

4.1.2 TEST CONFIGURATION

The valve shall be vertically mounted on the water test stand.

4.1.3 TEST PRESSURE

For a valve whose set pressure is greater than 50 pounds per square inch gauge (345 kilopascals gauge), the seat tightness shall be determined with the test pressure at the valve inlet held at 90 percent of the set pressure. For a valve set at 50 pounds per square inch gauge (345 kilopascals gauge) or less, the test pressure shall be held at 5 pounds per square inch (34.5 kilopascals) less than the set pressure.

4.1.4 LEAKAGE TEST

Before starting the seat tightness test, the set pressure shall be demonstrated, and the outlet body bowl shall be filled with water, which shall be allowed to stabilize with no visible flow from the valve outlet. The inlet pressure shall then be increased to the test pressure. The valve shall then be observed for 1 minute at the test pressure.

4.2 Acceptance Criteria

For a metal-seated valve whose inlet has a nominal pipe size of 1 inch or larger, the leakage rate shall not exceed 10 cubic centimeters per hour per inch of nominal inlet size. For a metal-seated valve whose inlet has a nominal pipe size of less than 1 inch, the

leakage rate shall not exceed 10 cubic centimeters per hour. For soft-seated valves, there shall be no leakage for 1 minute.

SECTION 5.

TESTING WITH AIR – ANOTHER METHOD

5.1 Type of Valve to be Tested

Valves with open bonnets – bonnets that cannot be readily sealed, as specified in 2.2.2 – may be tested in accordance with this section instead of Section 2.

This alternative method shall not be used to test valves in which air bubbles can travel to the open bonnet through any passageway inside the valve guide without being observed at the valve outlet.

5.2 Procedure

5.2.1 TEST MEDIUM

The test medium shall be air (or nitrogen) near ambient temperature.

5.2.2 TEST CONFIGURATION

The valve shall be vertically mounted on the air test stand. The valve outlet shall be partially sealed with water to about 1/2 inch (12.7 millimeters) above the nozzle's seating surface.

5.2.3 TEST PRESSURE

For a valve whose set pressure is greater than 50 pounds per square inch gauge (345 kilopascals gauge), the leakage rate in bubbles per minute shall be determined with the test pressure at the valve inlet held at 90 percent of the set pressure. For a valve set at 50 pounds per square inch gauge (345 kilopascals gauge) or less, the test pressure shall be held at 5 pounds per square inch (34.5 kilopascals)

less than the set pressure.

5.2.4 LEAKAGE TEST

Before starting the seat tightness test, the set pressure shall be demonstrated, and the outlet body bowl shall be filled with water to the level of the partial seal. The inlet pressure shall then be increased to the test pressure and held at this pressure for 1 minute before the bubble count. The valve shall then be observed for leakage for at least 1 minute.

CAUTION : When looking for leakage, the observer shall use a mirror or some other indirect means of observation so that the observer’s face is not in line with the outlet of the valve, in case the valve accidentally pops.

5.3 Acceptance Criteria

For a valve with a metal seat, the leakage rate in bubbles per minute shall not exceed 50 percent of the appropriate value in Table 1. For a soft-seated valve, there shall be leakage for 1 minute (0 bubbles per minute).

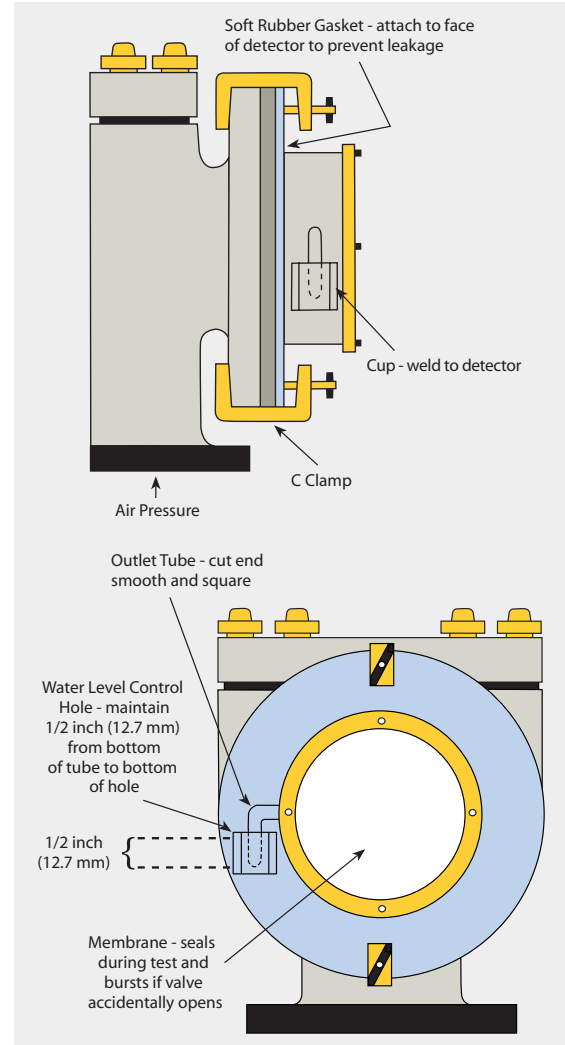

Set Pressure at 60°F (15.6°C)		Effective Orifice Sizes 0.307 Inch and Smaller			Effective Orifice Sizes Larger than 0.307 Inch		
		Leakage Rate (bubbles per minute)	Approximate Leakage per 24 Hours		Leakage Rate (bubbles per minute)	Approximate Leakage per 24 Hours	
Pounds per Square Inch Gauge	Mega-pascals		Standard Cubic Feet	Standard Cu- bic Meters		Standard Cubic Feet	Standard Cubic Meters
15 - 1000	0.103 - 6.896	40	0.60	0.017	20	0.30	0.0085
1500	10.3	60	0.90	0.026	30	0.45	0.013
2000	13.3	80	1.20	0.034	40	0.60	0.017
2500	17.2	100	1.50	0.043	50	0.75	0.021
3000	20.7	100	1.50	0.043	60	0.90	0.026
4000	27.6	100	1.50	0.043	80	1.20	0.034
5000	38.5	100	1.50	0.043	100	1.50	0.043
6000	41.4	100	1.50	0.043	100	1.50	0.043

Table 1- Maximum Seat Leakage Rates for Metal-Seated Pressure Relief Valve

Total Safety Solution Provider!

JOKWANG

JOKWANG I.L.I CO.,LTD.

HEAD OFFICE & FACTORY

No.37, Sanmakgongdan buk10-gil, Yangsan-si, Gyeongsangnam-do(Zip Code : 50567)

Tel : +82-55-360-0200 **Fax** : +82-55-360-0260 **E-mail** : trade@jokwang.co.kr

copyright © 2016 by JOKWANG I.L.I CO., LTD. All rights reserved@1209

www.jokwang.co.kr