



AIR VENT

TYPE JAV-FT11 (JKV-6)



Float type by bubble crush method for water

Application of BBC (Bubble Crush) method has made it possible to have no chattering and water-hammer. The valve disc and seat are easily removable with cover : even if soiled with scale and dust, they can be easily. Small in size and maximum working pressure is graded up to 10 kgf/cm²g {1.0MPa} Largest air venting capacity in this class. Provided with manual operating device.

Specifications

Pressure	: Max. 10kgf/cm ² {1.0MPa}
Temperature	: Max. 100°C
Size	: 15 & 20 mm (½" & ¾")
Weight	: 0.35kg
Connection	: PT Screwed (NPT, BSP available)
Hydraulic pressure test	: 15kgf/cm ² {1.5MPa}

Materials

No	Part name	Material
a	Cock	Brass
b	Seat	Brass
c	Valve	Silicon rubber
d	Valve holder	Brass
e	Float(Bubble crushing)	Polyethylene
f	Bonnet	Forged brass
g	Linking spring	Stainless Steel
h	Lever	Stainless Steel
i	Body	Forged brass

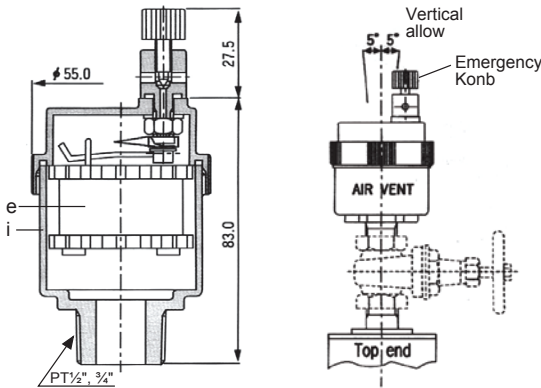

Installation and use

1. Install the valve vertically with allowance within 5° from the vertical axis.
2. Prior to installation, remove foreign matters remaining in piping and equipment.
3. Install a stop valve at the inlet to stop flow during maintenance inspection
4. In case of leakage, turn the knob to stop leakage.
5. In case of any possibility of freezing, cover the valve body with heat insulation material.



AIR VENT

TYPE JAV-CT11



Capsule type for steam

Model JAV-CT11 [JKV-4] a self-operating air vent to be used for eliminating air or non-condensable gas contained in steam, solving the air binding to ensure constant heat transferability and to prevent corrosion at the inside surface of pipe. As a bimetal operated air vent, the operating feature depends upon the temperature differential between steam and air. The valve closes at the steam temperature and opens when air or gas flows into the air vent.

Specifications

Applicable fluid	: Steam
Working pressure	: Max. 14kgf/cm ² {1.4MPa}
Working temperature	: Max. 200 °C
Connection	: PT Screwed (NTP, BSP thread type available)
Hydraulic pressure test	: 1.5 times working pressure

Materials

No	Part name	Material
a	Body	Bronze
b	Cap	Bronze
c	Seat	Stainless steel
d	Capsule	Stainless steel
e	Spring	Stainless steel
f	Screen	Stainless steel

Dimensions (mm)

Part	Size mm (inch)	15 (½")	20 (¾")
	d		PT ½"
L		40	42.5
H1		40.5	44.5
H2		22	20.5

