

## ND44



Electro-Voice

- Excellent acoustic control with aggressive and punctuated sound
- Large diaphragm dynamic capsule creates a rich and detailed frequency response
- Easy mic placement with low-profile pivoting head
- Humbucking coil guards against line hum
- Memraflex grille resists denting



The Electro-Voice ND44 is a robust, high-performance dynamic instrument microphone with a tight cardioid polar pattern.

Designed for excellent performance on drums and other rhythm section instruments, the ND44 capsule is precisely tuned to deliver the aggressive and punctuated sound these instruments produce, as well as excellent isolation from the sound of other nearby instruments.

The ND44 dynamic capsule contains a large Mylar diaphragm which delivers a rich and detailed frequency response by combining its large surface area for tonal balance with its low-mass high-velocity material for exceptionally fast transient response. The ND44 low profile pivoting head makes mic placement around a drum set easy. The included DRC-2 drum rim clamp is simple to use and eliminates the need for an additional mic stand.

The ND44 capsule uses a humbucking coil that attenuates AC hum and electromagnetic interference. ND dynamic mics can be used with confidence near speaker cabinets and EMF generating equipment racks.

The ND44 Memraflex grille is made of a durable tight-mesh grille wire that withstands extraordinarily-rough treatment. Your microphone remains protected and looking good gig-after-gig, year-after-year. For additional protection, the ND44 capsule contains a hydrophobic cloth membrane which prevents moisture and debris from reaching the diaphragm.

ND44 is also designed to function very well as a guitar cabinet mic. It can be stand-mounted using the optional SAND-1 stand adapter on a mic stand, or merely hung over the speaker cabinet with the grille facing the speaker cone using its mic cable to suspend it.

## Technical specifications

Element Type:	Dynamic neodymium magnet structure
Frequency Response, Free Field:	80Hz to 16.5kHz
Polar Pattern:	Tight Cardioid
Sensitivity, Open Circuit Voltage @ 1 kHz::	2.4 mV/Pascal
Maximum SPL:	> 140 dB SPL
Polarity:	Pin 2 positive, reference to pin 3 with positive pressure on diaphragm
Impedance:	350 ohms balanced (low-z)
Microphone Connector:	3-pin, XLR-type
Finish:	Black polyurethane paint
Material:	Zinc die cast handle, ABS-Polycarbonate Head, Memraflex grille screen

Dimensions, Head:	1.91 in (48.5 mm) Dia. X 1.94 in (49.22 mm) Long
Length:	5.47 in (139 mm)
Shank:	0.83 in (21 mm)
Net Weight:	6.85 oz (194 g)
Shipping Weight:	17.2 oz (488 g)
Accessories Included:	(1) DRC-2 Drum Rim Clamp, (1) Gig bag

**Frequency Response:**

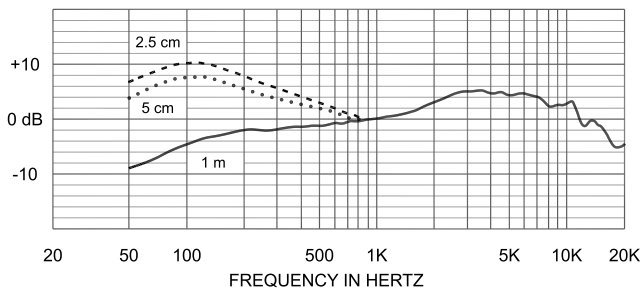

**Polar Response:**

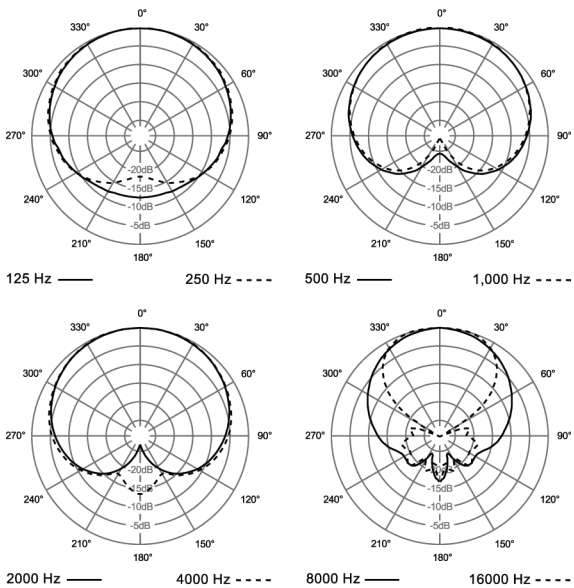

**Dimensions:**

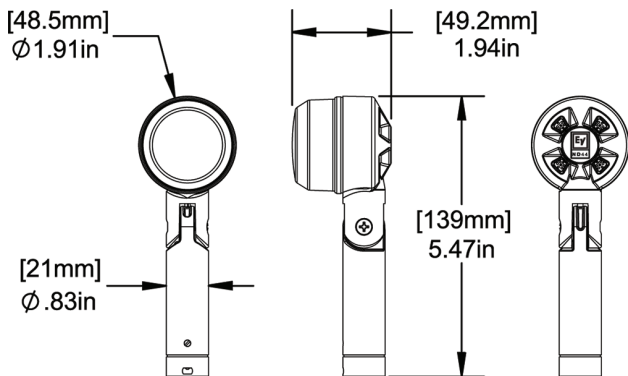

**System overview**

**Mounting the DRC-2 drum rim clamp to a drum rim:**

This method can be used with or without the ND Series microphone mounted in the clip (1).

To **mount the DRC-2 drum rim clamp to a drum rim**, do the following:

1. Grip the DRC-2 firmly by placing your index finger in the finger loop (2).

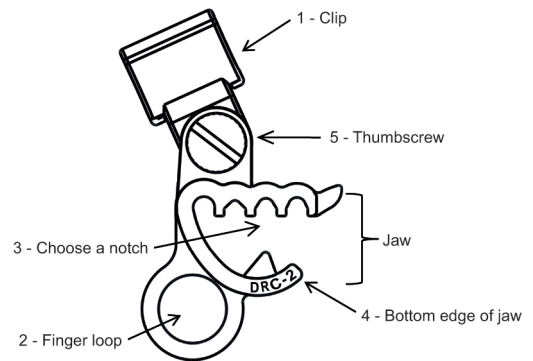

2. Choose a notch (3) at the top of the DRC-2 jaw and place it to the drum rim so the top edge of the rim fits inside the desired notch.
3. Using the finger you placed through the finger loop (2), pull downwards and allow the edge of the bottom DRC-2 jaw (4) to latch to the bottom edge of the drum rim.
4. Using the thumbscrew (5), tension can be adjusted on the pivoting joint as desired.

**Microphone Use and Placement:**

Please note that micing techniques are a matter of personal preference. These are merely guidelines to assist in the placement of the microphone to gain optimal performance.

Usage	Optimal Placement
Tom-Toms	On double headed Toms, place mic over the top of drum 1-3" and at a 45° angle to the drumhead surface and 1-2" in from the drum edge. On single headed Toms, use above method or place mic inside Tom from underneath at a 90° angle from the center of head, 3-5" away.
Snare Drum	Place mic 1-3" above the heads, 1-2" in from the rim. Aim each mic at the top heads angled down about 45°. If the drum rings, tape deadening material to the head or use damping rings. For more "snare" sound place a 2nd mic underneath aimed up at the bottom of head.
Electric Guitar and Bass Guitar Amplifier	Place microphone approximately 1-2" from and at a 90° degree angle to the speaker cone. To reduce boominess, move the microphone off axis to the cone from 90° to 45°, or move mic from center of cone to either edge.
Cymbals	Place microphone one to two feet above the cymbals.
High-Hat	Place 4-5" above outside edge at a 45° down angle.

Brass	6-24" away, and on axis with the bell of the instrument.
Acoustic Guitar	Place mic 6-12" from where neck joins the body.

#### Standard Placement and Use Guidelines:

1. Always point the microphone at the desired source of sound and away from any unwanted sources.
2. The microphone should be located close to the sound source to minimize interference from other potential sound sources.
3. Use the 3-to-1 rule when using multiple microphones. Place each microphone three times farther from other microphones as from the desired source.
4. Minimize over-handling of the microphone to reduce unwanted mechanical noise.
5. Working close to the microphone will increase the bass tone and also provide increased gain-before-feedback.

## Parts included

Qty.	Item
1	Microphone
1	Gig bag
1	DRC-2 drum rim clamp
1	Engineering data sheet
1	Warranty and Product Documentation Information card

## Ordering information

### ND44

Dynamic tight cardioid instrument microphone, black  
Order number **ND44**

### DRC-2

Drum rim clamp, black  
Order number **DRC-2**

### ND44GRILLE

Replacement end grille, black  
Order number **ND44GRILLE**

### Accessories

#### SAND-1

Stand adapter, black  
Order number **SAND-1**

**Represented by:**

---

**Germany:**

Bosch Sicherheitssysteme GmbH  
Robert-Bosch-Ring 5  
85630 Grasbrunn  
Germany

Bosch Security Systems, Inc.  
12000 Portland Avenue South  
Burnsville MN 55337  
USA

[www.electrovoice.com](http://www.electrovoice.com)