

Series EM730

Product Data

Definition	DATA	
Model	EM730-4R0-2B	
Application motor size kW (HP)	4 kW (5)	
Motor type	Asynchronous motor / Permanent-magnet motor	
OverLoad capability	Heavy-duty rated current	150% of rate current 60 seconds 180% of rate current 10 seconds 200% of rate current 2 seconds
	Light-duty rated current	120% of rate current 60 seconds 150% of rate current 10 seconds 180% of rate current 2 seconds
Starting torque	1Hz/150%(VVF) , 0.25Hz/150%(SVC)	
Rated input voltage (V)	3 phase : 220V(±10%)	
Rated input current (A)	24.6A	
Rated output voltage (V)	0 ~ input voltage	
Rated output current (A)	17A	
Output frequency (Hz)	0Hz ~ 600Hz / 0Hz ~ 3,000Hz	
Protective housing	IP20	
Cooling	Fan	
Carrier frequency	1 to 10 kHz	

Connecting Diagram

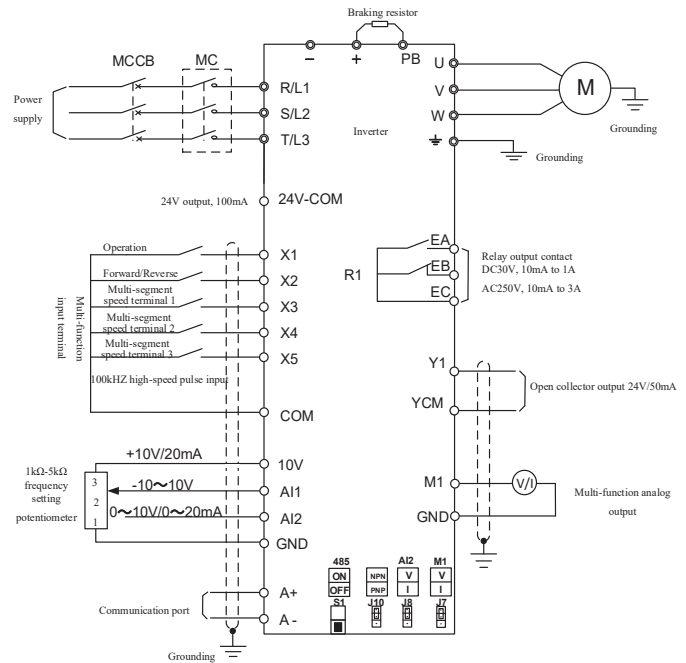

Dimension

W1 (mm)	W2 (mm)	H1 (mm)	H2 (mm)	D1 (mm)	D2 (mm)	Weight (Kg)
109	98	207	196	154	160	2.6

