

Series EM730



Product Data

Definition	DATA
Model	EM730-011-3B
Application motor size kW (HP)	11 kW (15)
Motor type	Asynchronous motor / Permanent-magnet motor
OverLoad capability	Heavy-duty rated current 150% of rate current 60 seconds 180% of rate current 10 seconds 200% of rate current 2 seconds
	Light-duty rated current 120% of rate current 60 seconds 150% of rate current 10 seconds 180% of rate current 2 seconds
Starting torque	1Hz/150%(VVF) , 0.25Hz/150%(SVC)
Rated input voltage (V)	3 phase : 340V(-10%) ~ 460V(+10%)
Rated input current (A)	32A
Rated output voltage (V)	0 ~ input voltage
Rated output current (A)	Heavy-duty 25A / Light-duty 28A
Output frequency (Hz)	0Hz ~ 600Hz / 0Hz ~ 3,000Hz
Protective housing	IP20
Cooling	Fan
Minimum value of resistor (Ω)	30Ω
Carrier frequency	1 to 8 kHz

Connecting Diagram

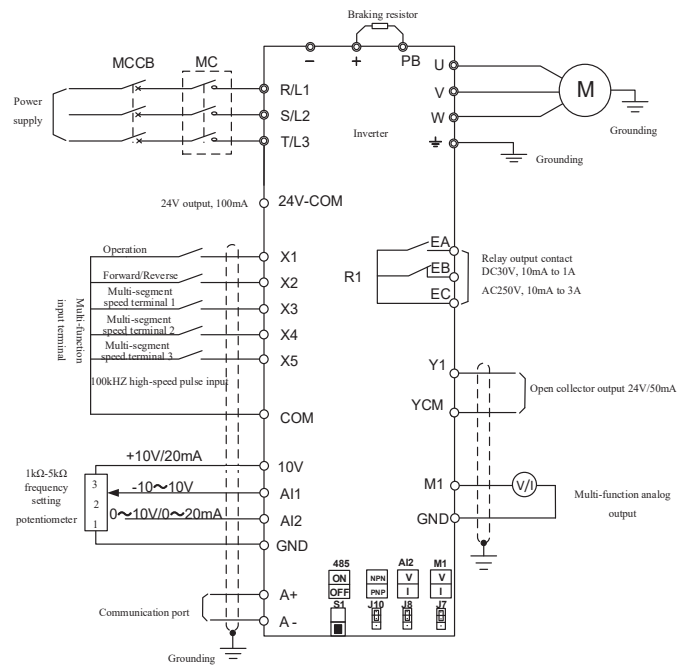

Dimension

W1 (mm)	W2 (mm)	H1 (mm)	H2 (mm)	D1 (mm)	D2 (mm)	Weight (Kg)
136	125	250	240	169	174	4.66

