

Series EM730



Product Data

| Definition | DATA | |
|--------------------------------|---|--|
| Model | EM730-7R5-2B | |
| Application motor size kW (HP) | 7.5 kW (10) | |
| Motor type | Asynchronous motor / Permanent-magnet motor | |
| OverLoad capability | Heavy-duty rated current | 150% of rate current 60 seconds 180% of rate current 10 seconds 200% of rate current 2 seconds |
| | Light-duty rated current | 120% of rate current 60 seconds 150% of rate current 10 seconds 180% of rate current 2 seconds |
| Starting torque | 1Hz/150%(VVF) , 0.25Hz/150%(SVC) | |
| Rated input voltage (V) | 3 phase : 220V(±10%) | |
| Rated input current (A) | 42A | |
| Rated output voltage (V) | 0 ~ input voltage | |
| Rated output current (A) | 32A | |
| Output frequency (Hz) | 0Hz ~ 600Hz / 0Hz ~ 3,000Hz | |
| Protective housing | IP20 | |
| Cooling | Fan | |
| Carrier frequency | 1 to 8 kHz | |

Connecting Diagram

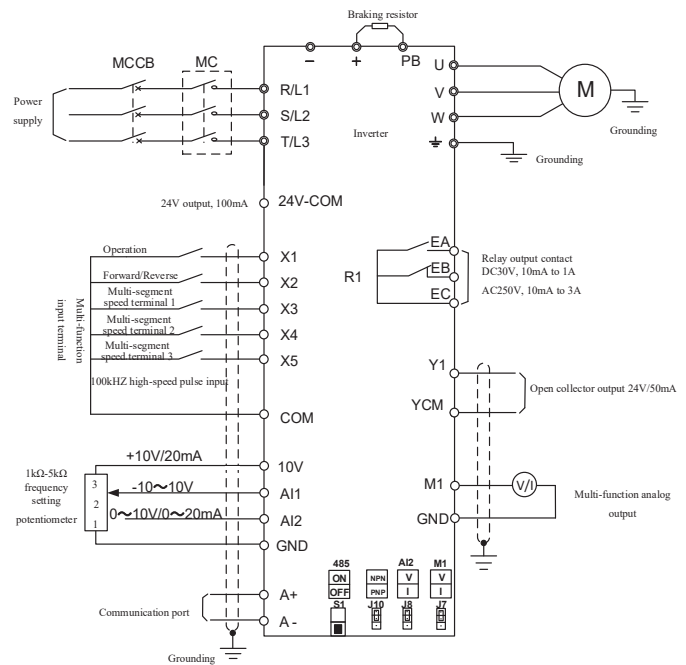

Dimension

| W1 (mm) | W2 (mm) | H1 (mm) | H2 (mm) | D1 (mm) | D2 (mm) | Weight (Kg) |
|---------|---------|---------|---------|---------|---------|-------------|
| 136 | 125 | 250 | 240 | 169 | 174 | 4.66 |

